

# Photometric Test Report



## ECLFRESNELCT+LIP

600W IP65 Led Fresnel with 6 color source  
250mm-10" lens  
(High Brightness Mode)

## CONTENTS

Table of contents	2
Testing process	4
Color preset Full on	
Max Zoom	5
Med Zoom	8
Min Zoom	11
Color preset Red	
Max Zoom	14
Med Zoom	17
Min Zoom	20
Color preset Green	
Max Zoom	23
Med Zoom	26
Min Zoom	29
Color preset Blue	
Max Zoom	32
Med Zoom	35
Min Zoom	38
Color preset Cyan	
Max Zoom	41
Med Zoom	44
Min Zoom	47
Color preset Mint	
Max Zoom	50
Med Zoom	53
Min Zoom	56
Color preset Amber	
Max Zoom	59
Med Zoom	62
Min Zoom	65

#### Color temperature 2800K

Max Zoom	68
Med Zoom	73
Min Zoom	78

#### Color temperature 3200K

Max Zoom	83
Med Zoom	88
Min Zoom	93

#### Color temperature 4000K

Max Zoom	98
Med Zoom	103
Min Zoom	108

#### Color temperature 5600K

Max Zoom	113
Med Zoom	118
Min Zoom	123

#### Color temperature 6000K

Max Zoom	128
Med Zoom	133
Min Zoom	138

## TESTING PROCESS

Prolights has its own optical testing laboratory in order to provide accurate photometric reports for its lighting products. The testing laboratory contains certain variety of precise lighting measurement systems that ensure an optimal reading of all the characteristic parameters of the lighting devices. All measurements are made at a controlled room temperature of 20°C without any external light sources. This photometric report is obtained through the data measured by a high precision measurement system and analyzed by a dedicate software.

### Prolights measurement instrument

Prolights measurement instrument is a complete measurement system for any light source. It's equipped with two-axis goniometer, that enables to measure the full 3D distribution field of the light source. This instrument measures the light intensity, the beam angle and the most significative colors parameters, like color temperature, spectral distribution, CRI, CQS, TM-30 with a very high accuracy rate.

**Please Note:** All measurements are made with light source at operating temperature. Before starting the measurement, the instrument analyzes the process of the light source during the heating phase. The measuring process of all the parameters begins only when the light emission is stable, that is with a variation of less than 0.5% in a 15 minutes time frame.

### Prolights measurement software

The software provides user friendly interface for the operator who does the measurements, and it also analyzes and processes all the collected data by the instrument. With this software it is possible to see the measured data in real-time and it is possible to examine all the measured data and graphics afterwards as well. All information is collected in a specific Prolights template, and the software creates also IES and LDT files, which are widely used to transfer the photometric data, and to develop lighting system.

Additionally, the fixtures are rechecked using various hand-held instruments like Sekonic C-700 and Gossen Mavospec Base, this is done to ensure, that the data in the photometric report are as accurate as possible.



Total lumen output:

13257 lm

Peak candela output:

17403 cd

PRODUCT NAME:

ECLFRCTPLIP

MEASURAMENT CONDITIONS:

Beam angle:

Max Zoom

Target:

Full On - HB

Operator:

Salvatore Giglio

Date and time:

21/09/2023 13:42:02

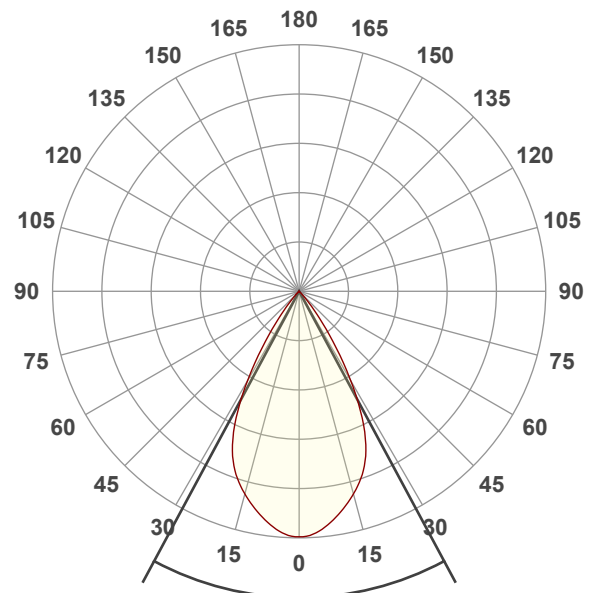

Beam angle 50%: 56,5°

Field angle 10%: 77,2°

Cut off angle 2.5%: 86,4°

Spectra

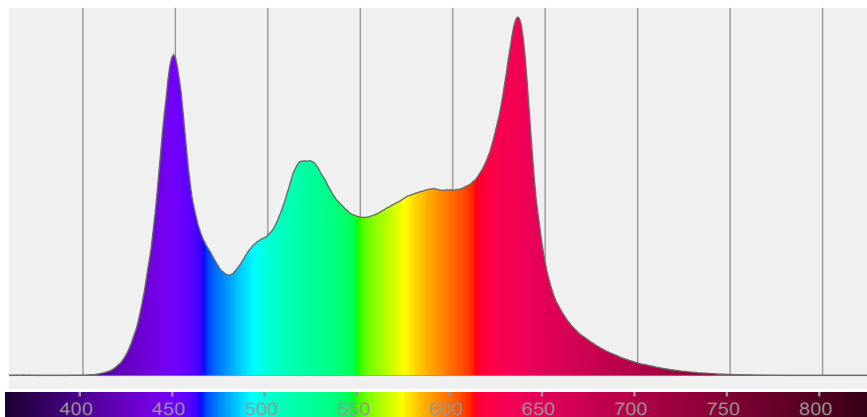

# BEAM DETAILS



Beam angle 50%	Field angle 10%	Cut off angle 2,5%	Intensity ratio in 120° cone	Intensity ratio in 90° cone
56,5°	77,2°	86,4°	100,0%	99,7%

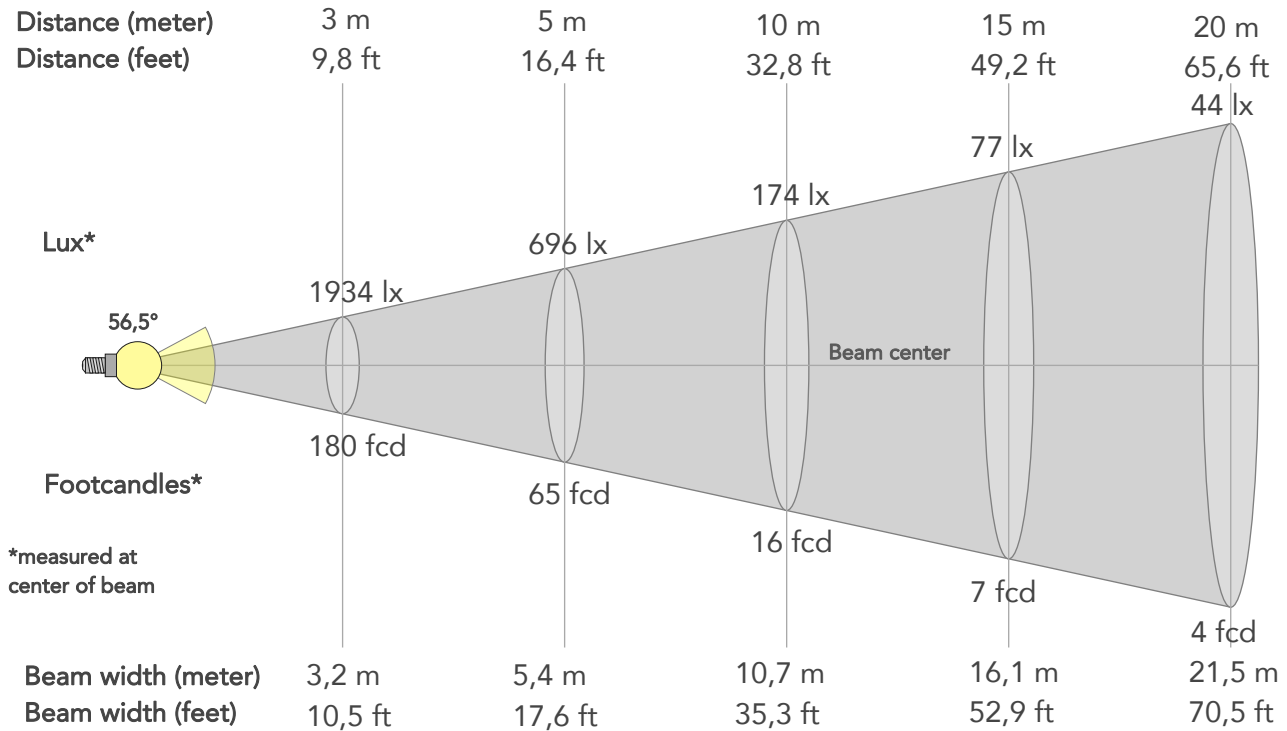

## BEAM INTENSITIES AND WIDTHS

Distance	1m	2m	3m	4m	5m	7,5m	10m	15m	20m	25m	30m	40m	50m
Distance	3,3ft	6,6ft	9,8ft	13,1ft	16,4ft	24,6ft	32,8ft	49,2ft	65,6ft	82ft	98,4ft	131,2ft	164ft
Lux	17403lx	4351lx	1934lx	1088lx	696lx	309lx	174lx	77lx	44lx	28lx	19lx	11lx	7lx
Footcand.	1617fcd	404fcd	180fcd	101fcd	65fcd	29fcd	16fcd	7fcd	4fcd	3fcd	2fcd	1fcd	1fcd
Beam wid.	1,1m	2,1m	3,2m	4,3m	5,4m	8,1m	10,7m	16,1m	21,5m	26,9m	32,2m	43m	53,7m
Beam wid.	3,5ft	7,1ft	10,5ft	14,1ft	17,6ft	26,4ft	35,3ft	52,9ft	70,5ft	88,1ft	105,8ft	141ft	176,3ft

## LINEAR DISTRIBUTION DIAGRAM

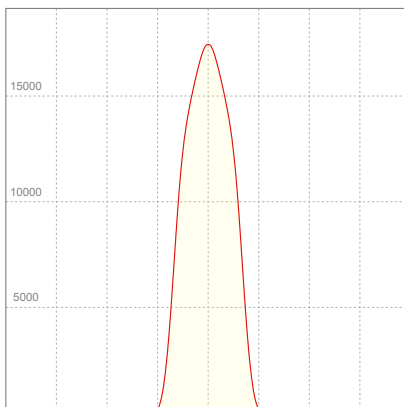

## ELECTRICAL SPECIFICATIONS

Input voltage	Input current	Input power	Effeciency
226V	2,48A	557W	24lm/W

Power FC
1,0

## ISO CANDELA DIAGRAM

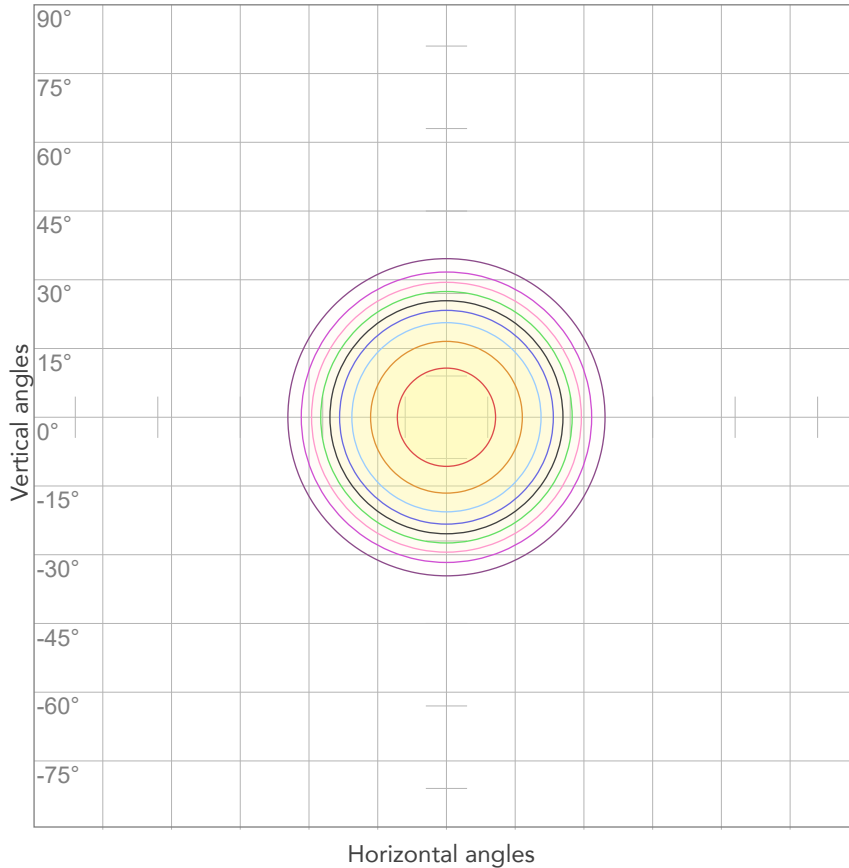

10%	1740 cd
20%	3481 cd
30%	5221 cd
40%	6961 cd
50%	8701 cd
60%	10442 cd
70%	12182 cd
80%	13922 cd

Conditions:

Number of c-planes: 2

Candela at center: 17403 cd

## ISO LUX DIAGRAM

MH: 10,0 m

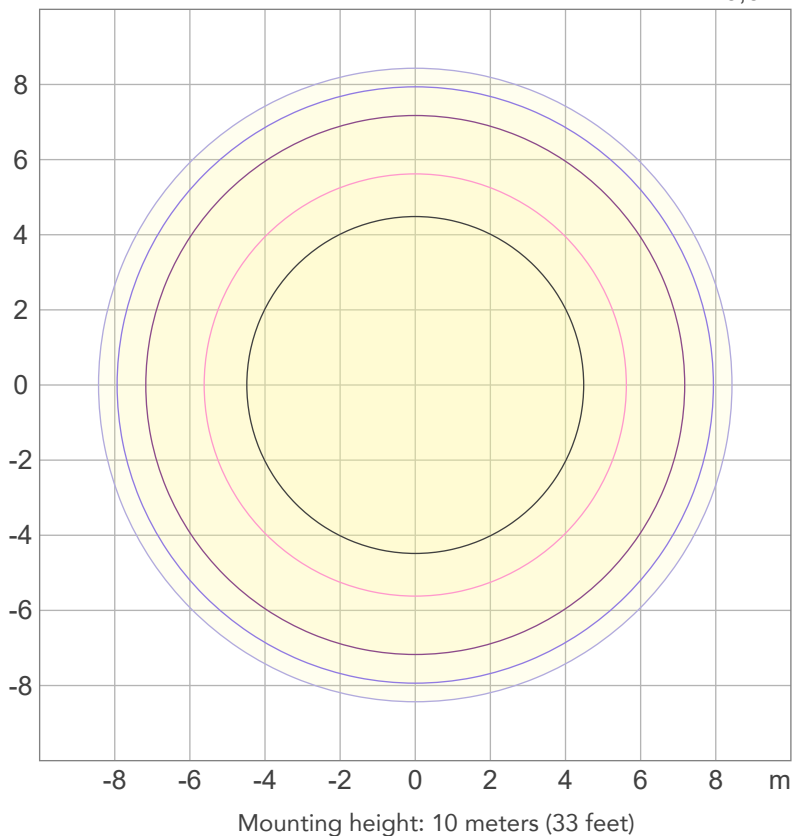

3%	5,22 lx
5%	8,70 lx
10%	17,4 lx
30%	52,2 lx
50%	87,0 lx

Conditions:

Number of c-planes: 2

Lux at center: 174 lx

*Lux distribution on a surface when lamp is mounted at 10 meters from the surface.*



Total lumen output:

10648 lm

Peak candela output:

57118 cd

**PRODUCT NAME:**  
**ECLFRCTPLIP**

**MEASURAMENT CONDITIONS:**

Beam angle:  
Med Zoom

Target:  
Full On - HB

Operator:  
Salvatore Giglio

Date and time:  
21/09/2023 13:40:01

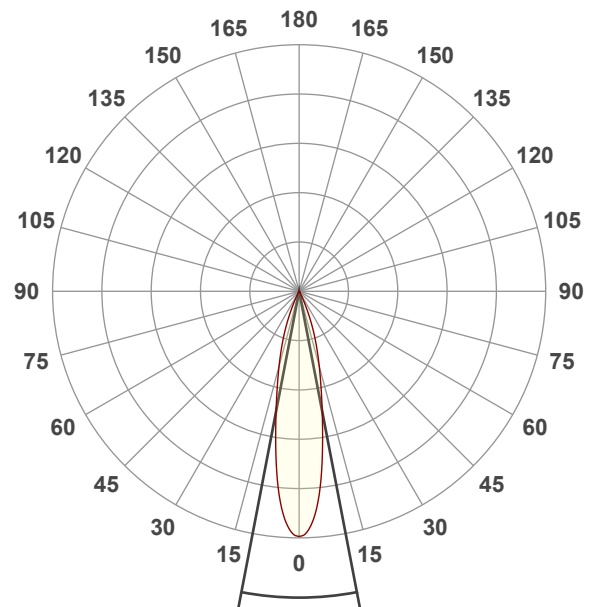

Beam angle 50%: 21,7°  
Field angle 10%: 44,9°  
Cut off angle 2.5%: 53,6°

Spectra

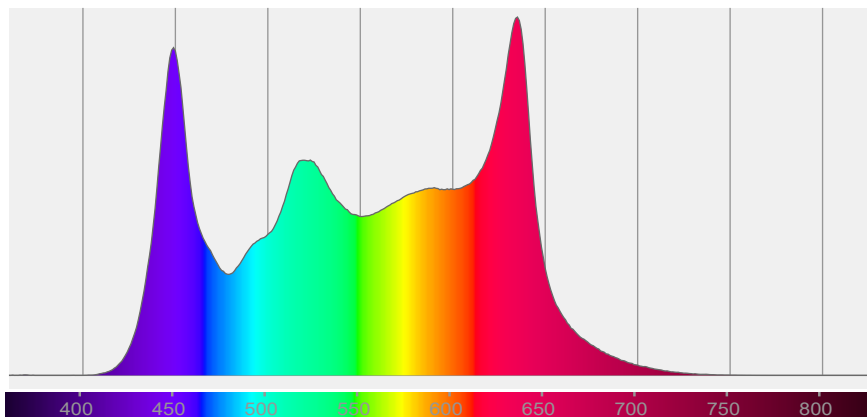



# BEAM DETAILS



Beam angle 50%	Field angle 10%	Cut off angle 2,5%	Intensity ratio in 120° cone	Intensity ratio in 90° cone
21,7°	44,9°	53,6°	100,0%	100,0%

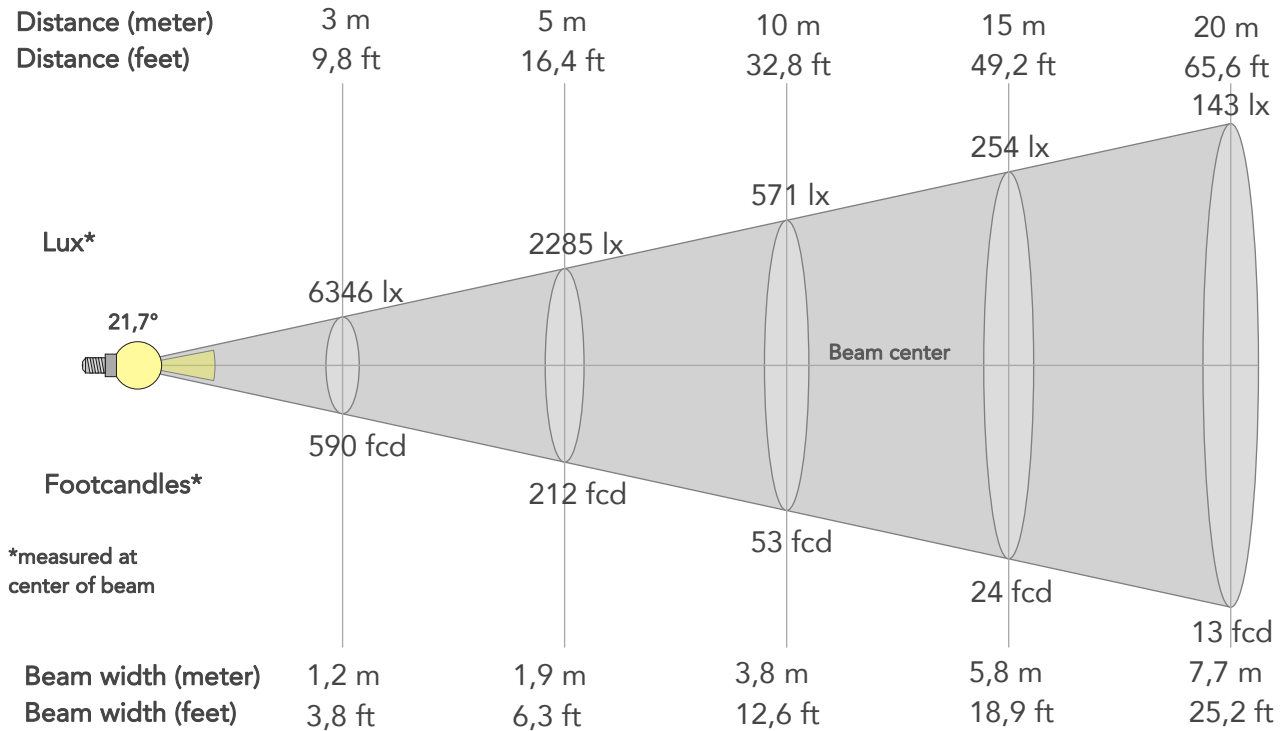

## BEAM INTENSITIES AND WIDTHS

Distance	1m	2m	3m	4m	5m	7,5m	10m	15m	20m	25m	30m	40m	50m
Distance	3,3ft	6,6ft	9,8ft	13,1ft	16,4ft	24,6ft	32,8ft	49,2ft	65,6ft	82ft	98,4ft	131,2ft	164ft
Lux	57118lx	14279lx	6346lx	3570lx	2285lx	1015lx	571lx	254lx	143lx	91lx	63lx	36lx	23lx
Footcand.	5306fcd	1327fcd	590fcd	332fcd	212fcd	94fcd	53fcd	24fcd	13fcd	8fcd	6fcd	3fcd	2fcd
Beam wid.	0,4m	0,8m	1,2m	1,5m	1,9m	2,9m	3,8m	5,8m	7,7m	9,6m	11,5m	15,4m	19,2m
Beam wid.	1,3ft	2,5ft	3,8ft	5ft	6,3ft	9,4ft	12,6ft	18,9ft	25,2ft	31,5ft	37,8ft	50,4ft	63ft

## LINEAR DISTRIBUTION DIAGRAM

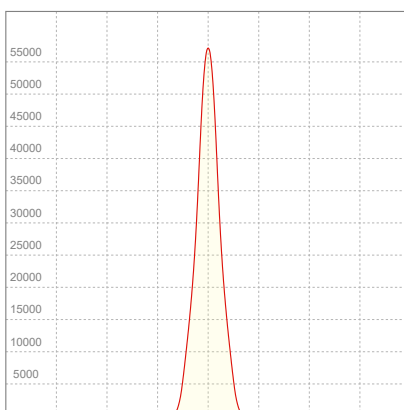

## ELECTRICAL SPECIFICATIONS

Input voltage	Input current	Input power	Effeciency
226V	2,49A	560W	19lm/W

Power FC
1,0

## ISO CANDELA DIAGRAM

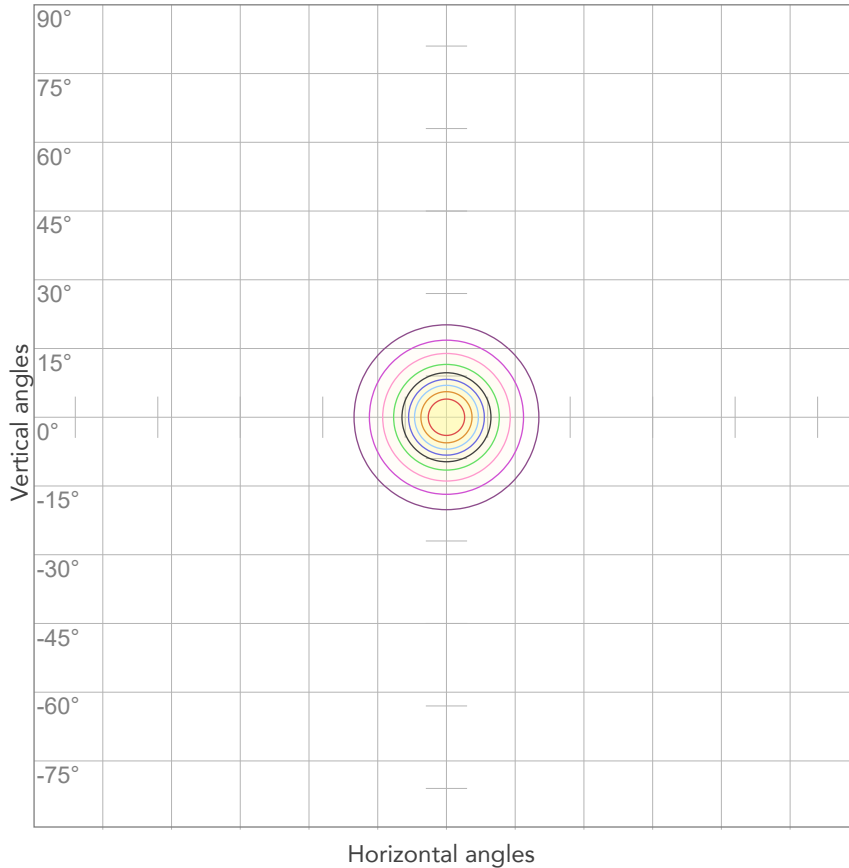

10%	5712 cd
20%	11424 cd
30%	17135 cd
40%	22847 cd
50%	28559 cd
60%	34271 cd
70%	39982 cd
80%	45694 cd

Conditions:

Number of c-planes: 2

Candela at center: 57118 cd

## ISO LUX DIAGRAM

MH: 10,0 m

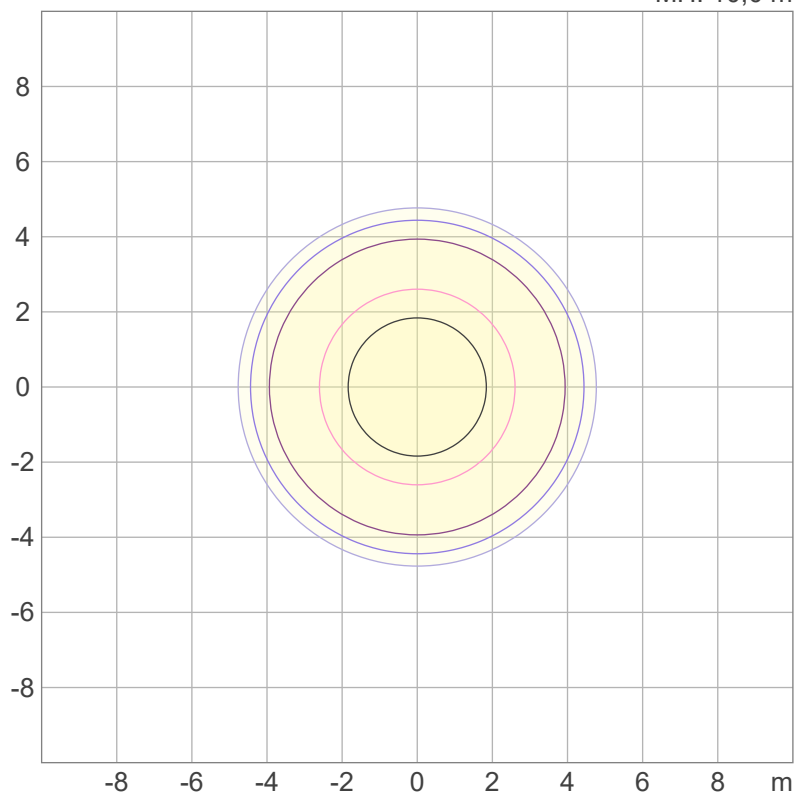

3%	17,1 lx
5%	28,6 lx
10%	57,1 lx
30%	171 lx
50%	286 lx

Conditions:

Number of c-planes: 2

Lux at center: 571 lx

*Lux distribution on a surface when lamp is mounted at 10 meters from the surface.*



Total lumen output:

5697 lm

Peak candela output:

148646 cd

**PRODUCT NAME:**  
**ECLFRCTPLIP**

**MEASURAMENT CONDITIONS:**

Beam angle:

Min Zoom

Target:

Full On - HB

Operator:

Salvatore Giglio

Date and time:

21/09/2023 12:05:46

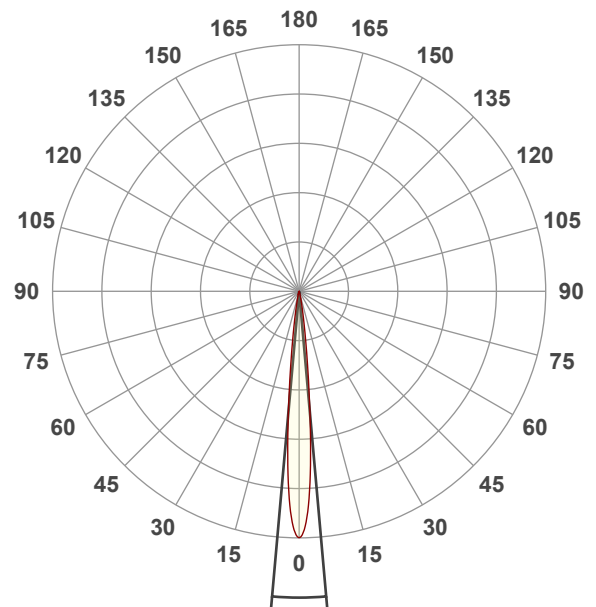

Beam angle 50%: 10,1°

Field angle 10%: 18,8°

Cut off angle 2.5%: 26,3°

Spectra

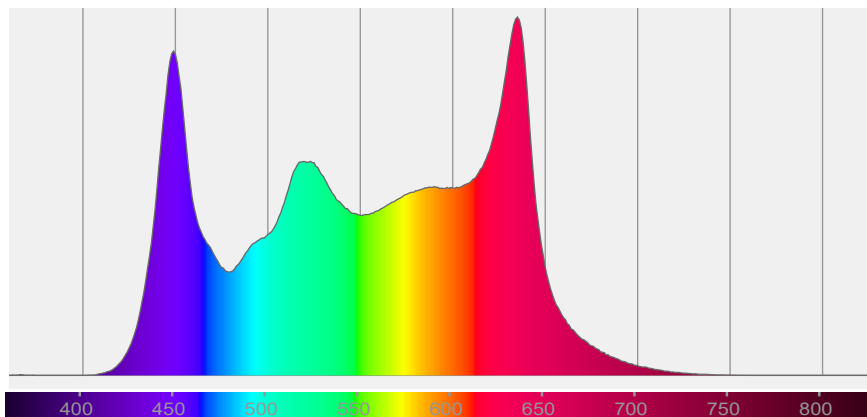

# BEAM DETAILS



Beam angle 50%	Field angle 10%	Cut off angle 2,5%	Intensity ratio in 120° cone	Intensity ratio in 90° cone
10,1°	18,8°	26,3°	100,0%	100,0%

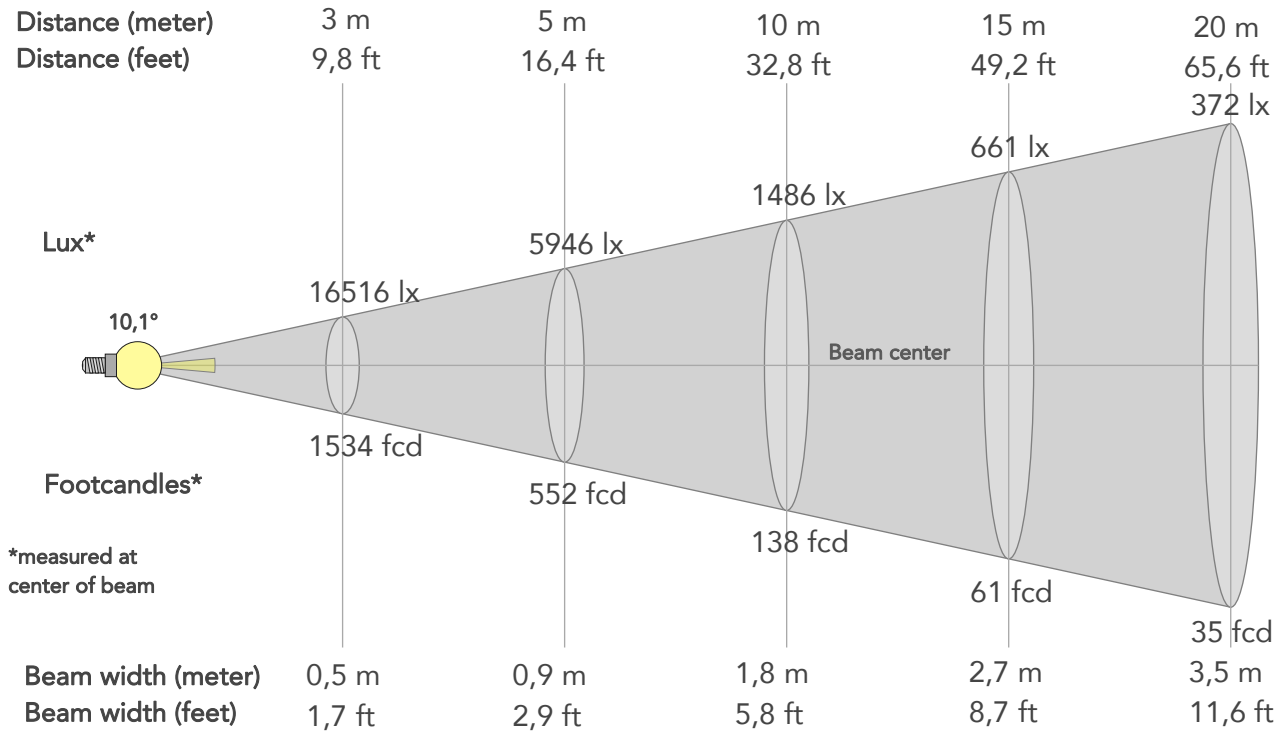

## BEAM INTENSITIES AND WIDTHS

Distance	1m	2m	3m	4m	5m	7,5m	10m	15m	20m	25m	30m	40m	50m
Distance	3,3ft	6,6ft	9,8ft	13,1ft	16,4ft	24,6ft	32,8ft	49,2ft	65,6ft	82ft	98,4ft	131,2ft	164ft
Lux	148646lx	37161lx	16516lx	9290lx	5946lx	2643lx	1486lx	661lx	372lx	238lx	165lx	93lx	59lx
Footcand.	13810fcd	3452fcd	1534fcd	863fcd	552fcd	246fcd	138fcd	61fcd	35fcd	22fcd	15fcd	9fcd	6fcd
Beam wid.	0,2m	0,4m	0,5m	0,7m	0,9m	1,3m	1,8m	2,7m	3,5m	4,4m	5,3m	7,1m	8,9m
Beam wid.	0,6ft	1,2ft	1,7ft	2,3ft	2,9ft	4,4ft	5,8ft	8,7ft	11,6ft	14,5ft	17,4ft	23,3ft	29,1ft

## LINEAR DISTRIBUTION DIAGRAM

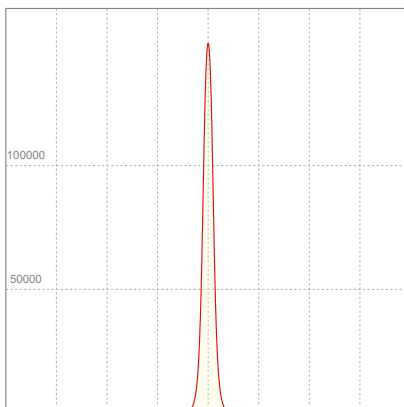

## ELECTRICAL SPECIFICATIONS

Input voltage	Input current	Input power	Effeciency
225V	2,51A	560,5W	10lm/W

Power FC
1,0

## ISO CANDELA DIAGRAM

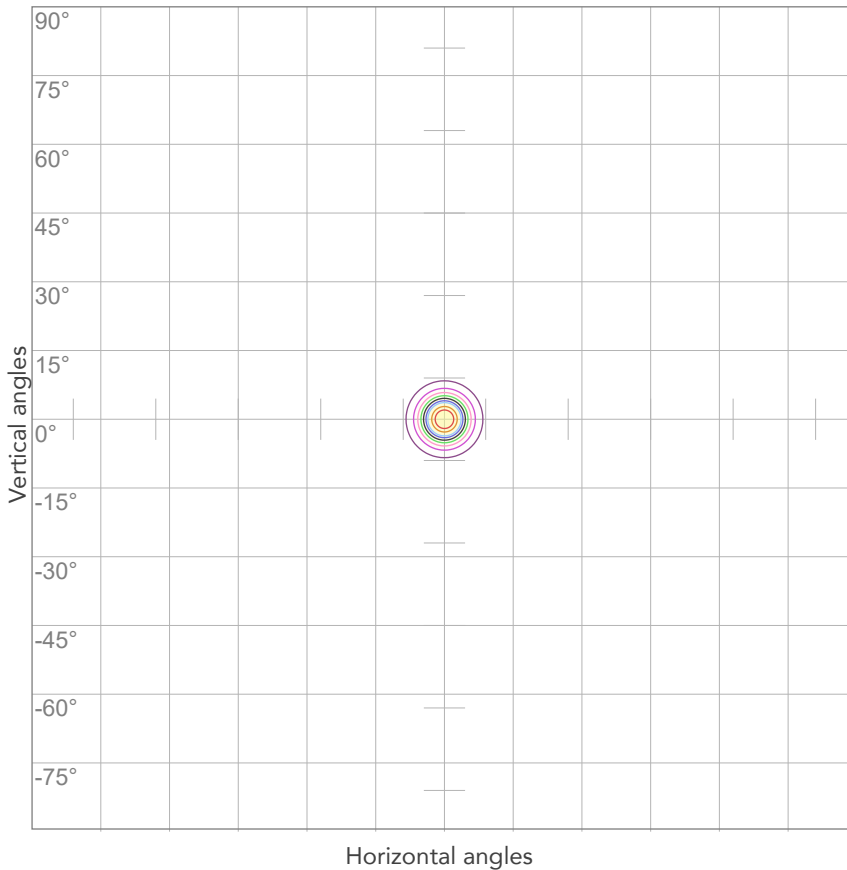

10%	14865 cd
20%	29729 cd
30%	44594 cd
40%	59458 cd
50%	74323 cd
60%	89188 cd
70%	104052 cd
80%	118917 cd

Conditions:

Number of c-planes: 2

Candela at center: 148646 cd

## ISO LUX DIAGRAM

MH: 10,0 m

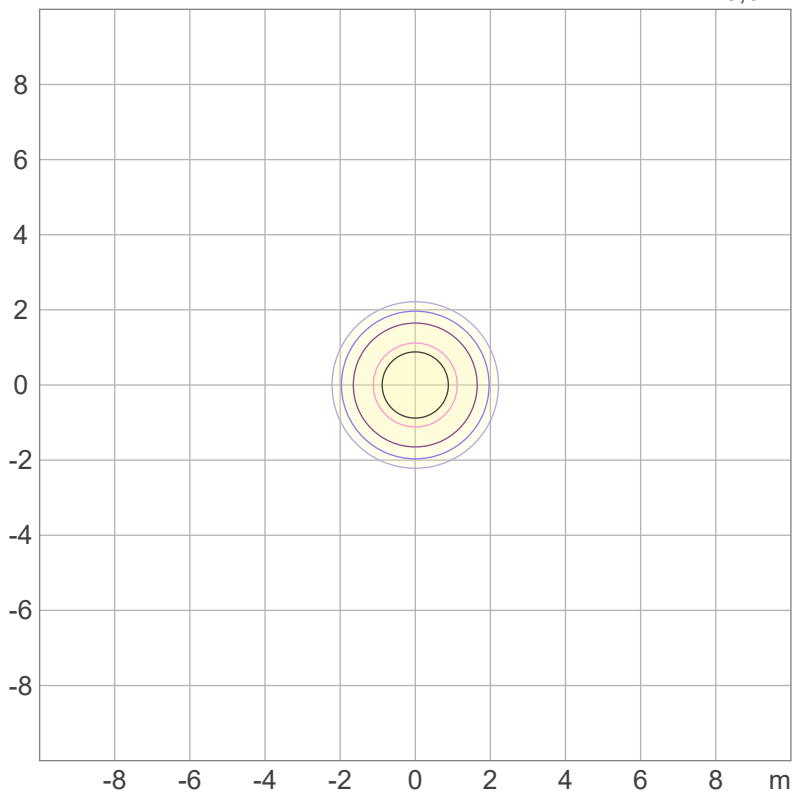

Mounting height: 10 meters (33 feet)

3%	44,6 lx
5%	74,3 lx
10%	149 lx
30%	446 lx
50%	743 lx

Conditions:

Number of c-planes: 2

Lux at center: 1486 lx

*Lux distribution on a surface when lamp is mounted at 10 meters from the surface.*



Total lumen output:

1365 lm

Peak candela output:

1781 cd

**PRODUCT NAME:**

**ECLFRCTPLIP**

**MEASURAMENT CONDITIONS:**

Beam angle:

Max Zoom

Target:

Red - HB

Operator:

Salvatore Giglio

Date and time:

03/10/2023 13:17:39

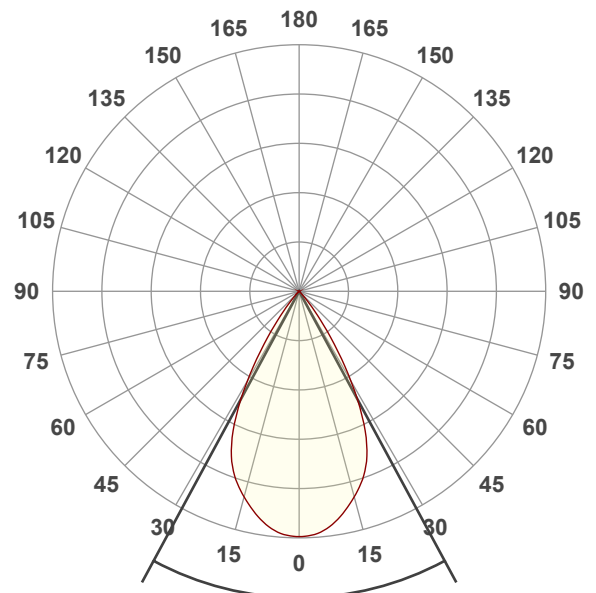

Beam angle 50%: 56,7°

Field angle 10%: 76,8°

Cut off angle 2.5%: 85,7°

Spectra

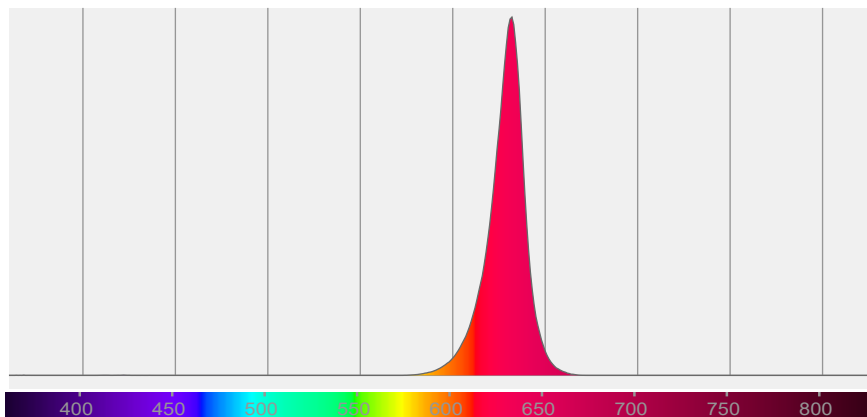

# BEAM DETAILS



Beam angle 50%	Field angle 10%	Cut off angle 2,5%	Intensity ratio in 120° cone	Intensity ratio in 90° cone
56,7°	76,8°	85,7°	100,0%	99,7%

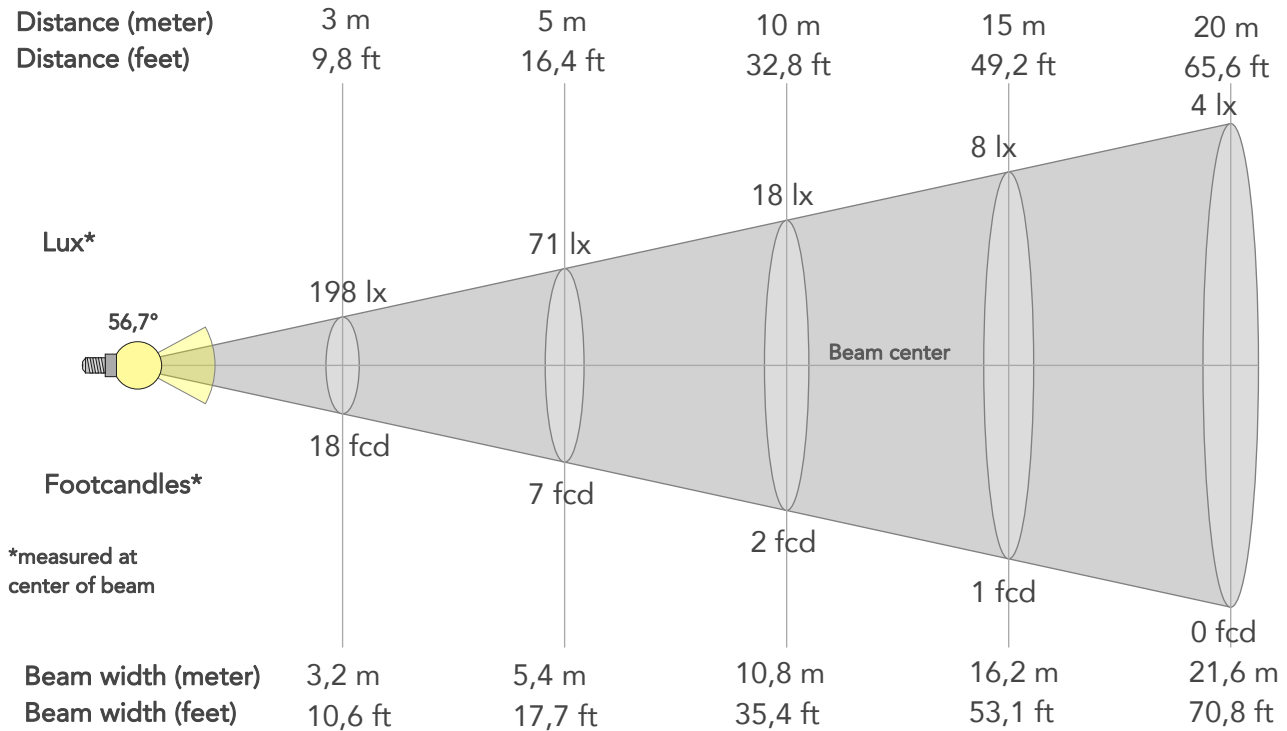

## BEAM INTENSITIES AND WIDTHS

Distance	1m	2m	3m	4m	5m	7,5m	10m	15m	20m	25m	30m	40m	50m
Distance	3,3ft	6,6ft	9,8ft	13,1ft	16,4ft	24,6ft	32,8ft	49,2ft	65,6ft	82ft	98,4ft	131,2ft	164ft
Lux	1781lx	445lx	198lx	111lx	71lx	32lx	18lx	8lx	4lx	3lx	2lx	1lx	1lx
Footcand.	165fcd	41fcd	18fcd	10fcd	7fcd	3fcd	2fcd	1fcd	0fcd	0fcd	0fcd	0fcd	0fcd
Beam wid.	1,1m	2,2m	3,2m	4,3m	5,4m	8,1m	10,8m	16,2m	21,6m	27m	32,4m	43,2m	54m
Beam wid.	3,6ft	7,1ft	10,6ft	14,1ft	17,7ft	26,6ft	35,4ft	53,1ft	70,8ft	88,6ft	106,3ft	141,7ft	177,1ft

## LINEAR DISTRIBUTION DIAGRAM

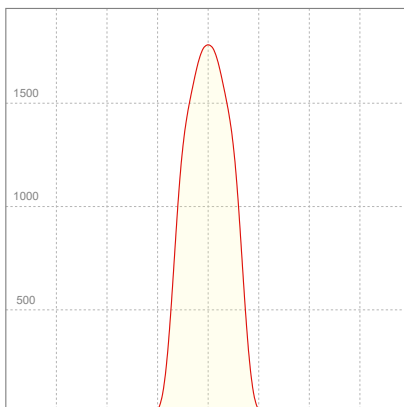

## ELECTRICAL SPECIFICATIONS

Input voltage	Input current	Input power	Effeciency
229V	0,491A	96,2W	14lm/W

Power FC
0,86

## ISO CANDELA DIAGRAM

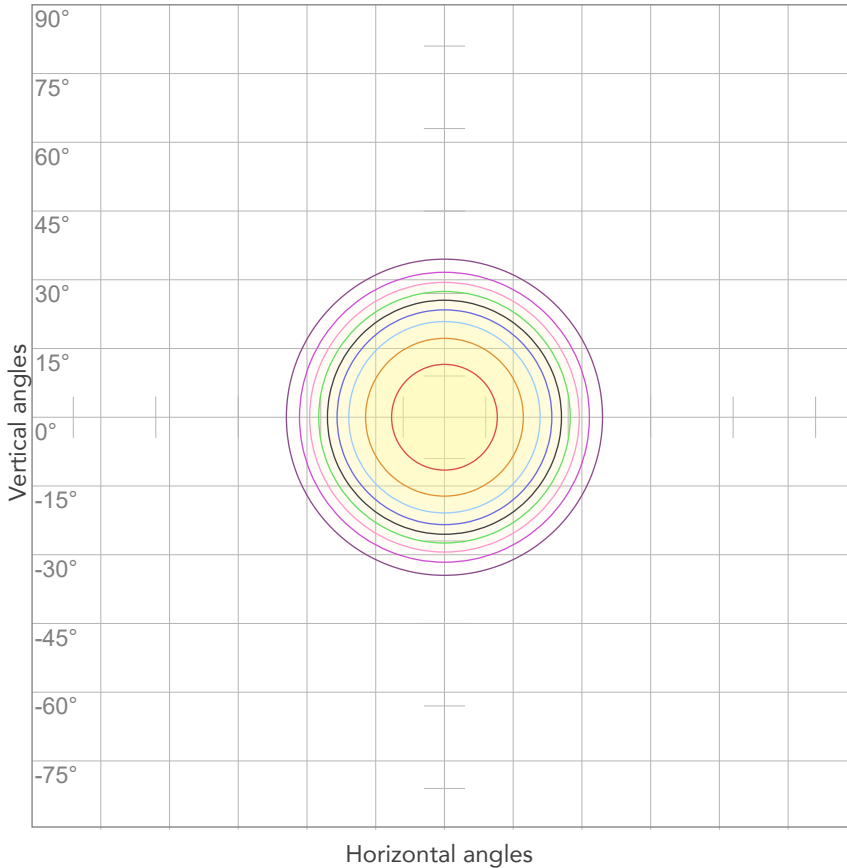

10%	178 cd
20%	356 cd
30%	534 cd
40%	712 cd
50%	890 cd
60%	1068 cd
70%	1246 cd
80%	1425 cd

Conditions:

Number of c-planes: 2

Candela at center: 1781 cd

## ISO LUX DIAGRAM

MH: 10,0 m

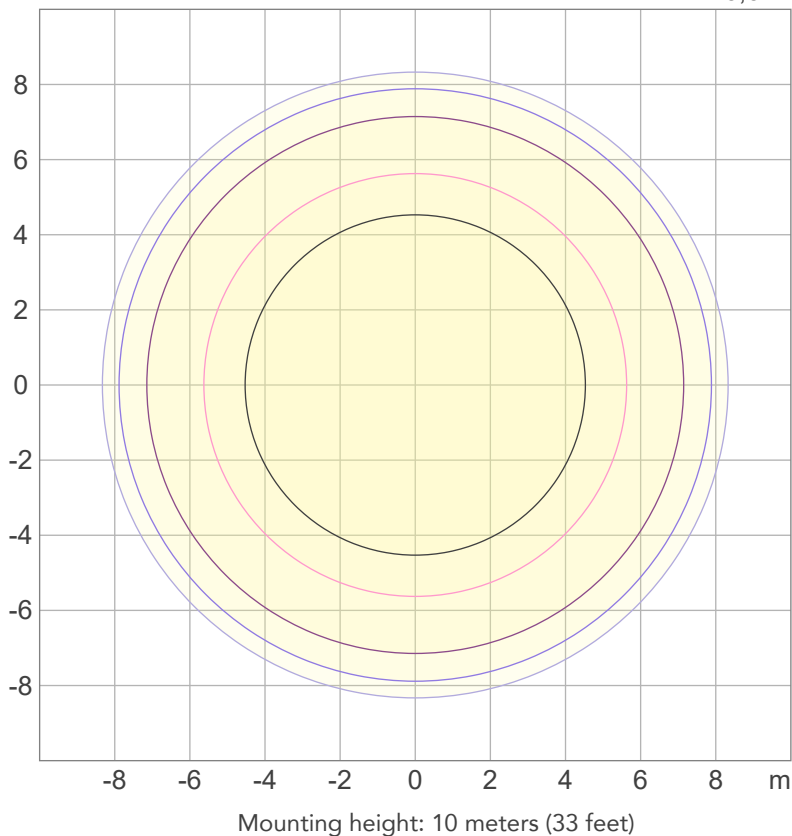

3%	0,534 lx
5%	0,890 lx
10%	1,78 lx
30%	5,34 lx
50%	8,90 lx

Conditions:

Number of c-planes: 2

Lux at center: 17,8 lx

*Lux distribution on a surface when lamp is mounted at 10 meters from the surface.*





Total lumen output:

1071 lm

Peak candela output:

5707 cd

**PRODUCT NAME:**  
**ECLFRCTPLIP**

**MEASURAMENT CONDITIONS:**

Beam angle:  
Med Zoom

Target:  
Red - HB

Operator:  
Salvatore Giglio

Date and time:  
03/10/2023 14:45:10

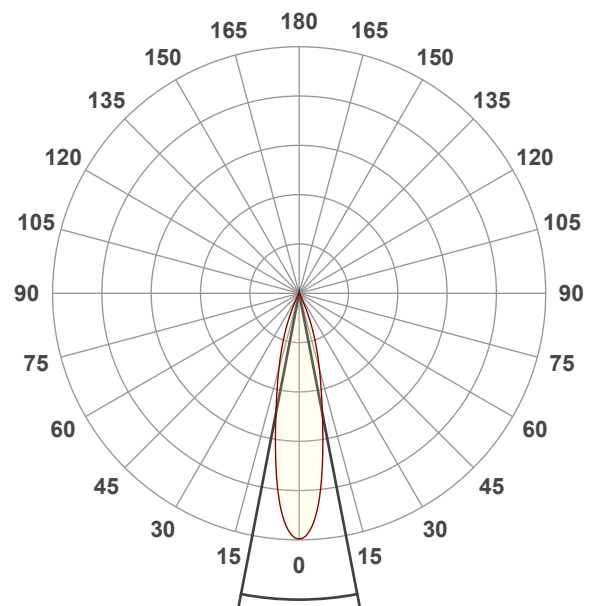

Beam angle 50%: 21,9°  
Field angle 10%: 44,8°  
Cut off angle 2.5%: 53,3°

Spectra

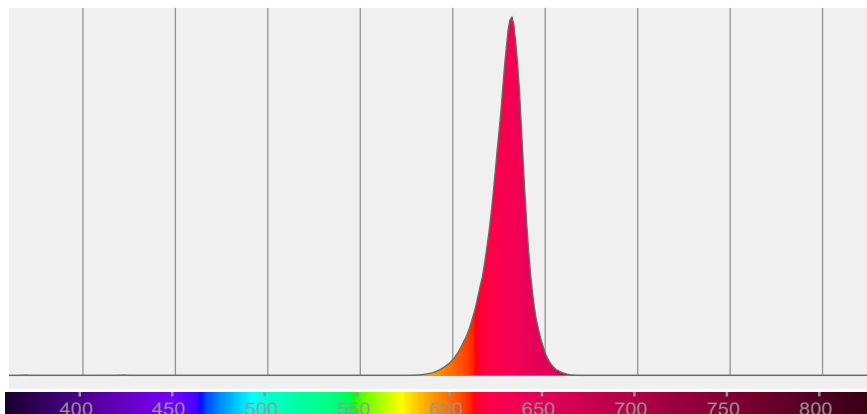

# BEAM DETAILS



Beam angle 50%	Field angle 10%	Cut off angle 2,5%	Intensity ratio in 120° cone	Intensity ratio in 90° cone
21,9°	44,8°	53,3°	100,0%	100,0%

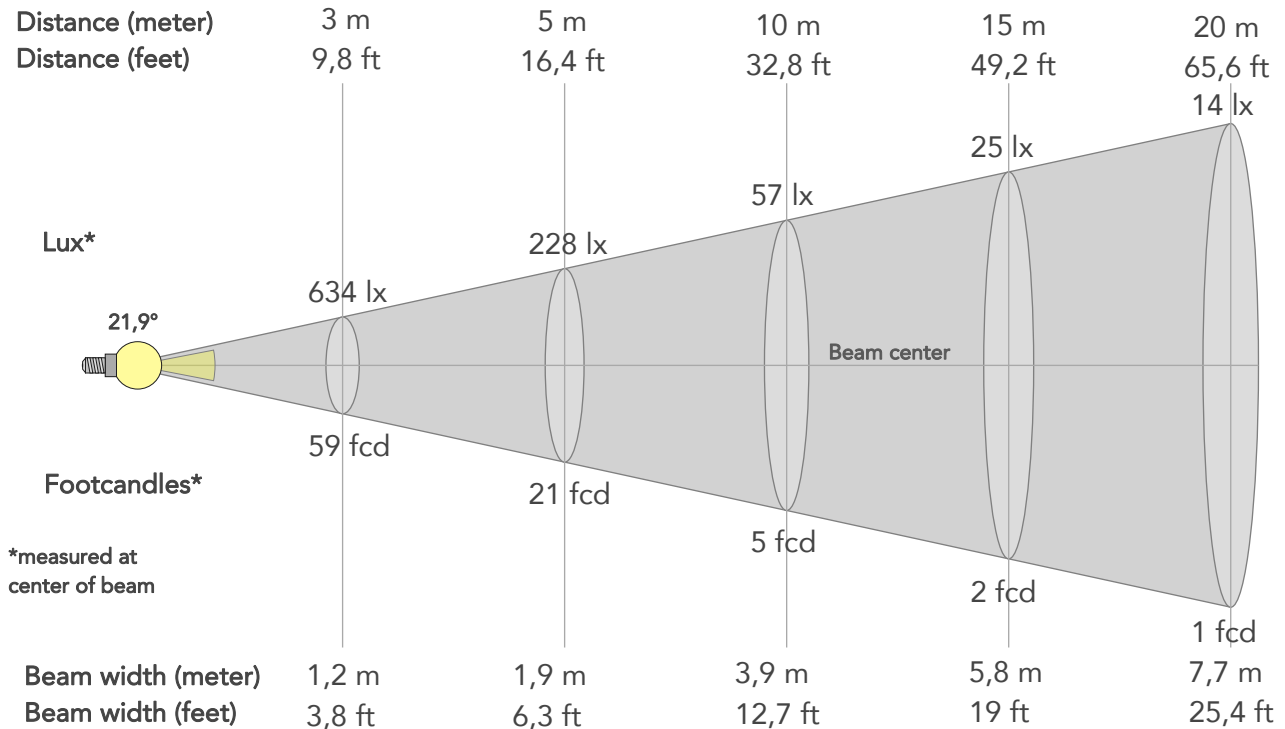

## BEAM INTENSITIES AND WIDTHS

Distance	1m	2m	3m	4m	5m	7,5m	10m	15m	20m	25m	30m	40m	50m
Distance	3,3ft	6,6ft	9,8ft	13,1ft	16,4ft	24,6ft	32,8ft	49,2ft	65,6ft	82ft	98,4ft	131,2ft	164ft
Lux	5707lx	1427lx	634lx	357lx	228lx	101lx	57lx	25lx	14lx	9lx	6lx	4lx	2lx
Footcand.	530fcd	133fcd	59fcd	33fcd	21fcd	9fcd	5fcd	2fcd	1fcd	1fcd	1fcd	0fcd	0fcd
Beam wid.	0,4m	0,8m	1,2m	1,5m	1,9m	2,9m	3,9m	5,8m	7,7m	9,7m	11,6m	15,5m	19,3m
Beam wid.	1,3ft	2,6ft	3,8ft	5,1ft	6,3ft	9,5ft	12,7ft	19ft	25,4ft	31,7ft	38ft	50,7ft	63,4ft

## LINEAR DISTRIBUTION DIAGRAM

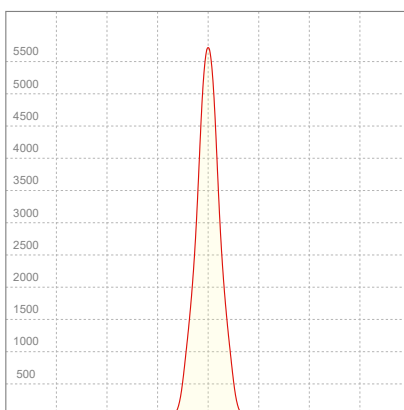

## ELECTRICAL SPECIFICATIONS

Input voltage	Input current	Input power	Effeciency
228V	0,491A	96,0W	11lm/W

Power FC
0,86

## ISO CANDELA DIAGRAM

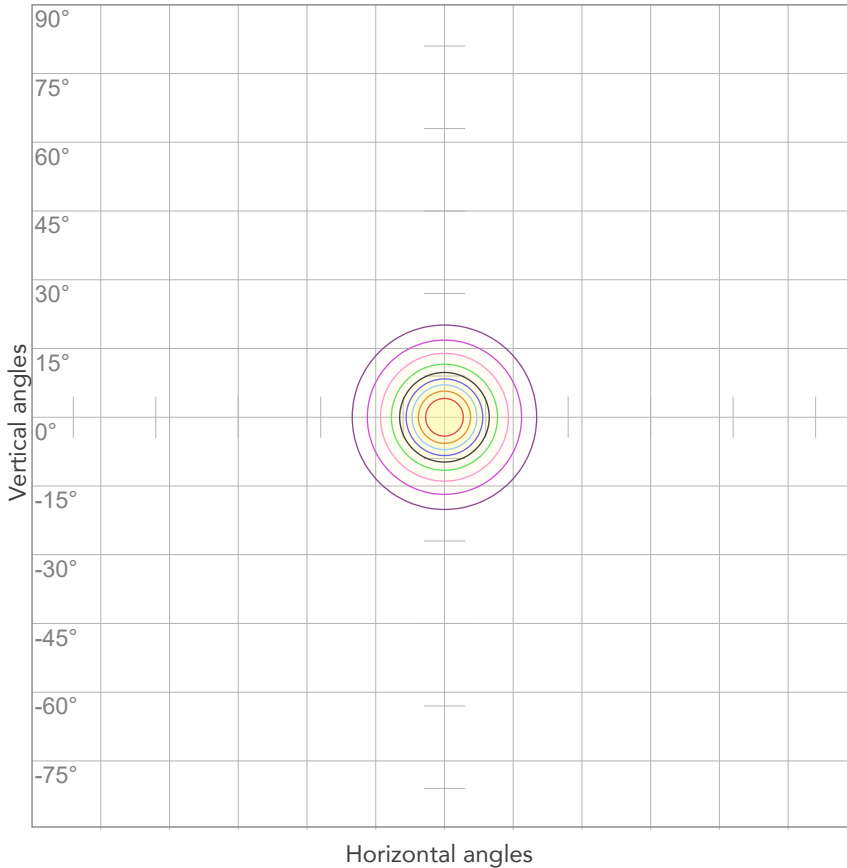

10%	571 cd
20%	1141 cd
30%	1712 cd
40%	2283 cd
50%	2853 cd
60%	3424 cd
70%	3995 cd
80%	4565 cd

Conditions:

Number of c-planes: 2

Candela at center: 5707 cd

## ISO LUX DIAGRAM

MH: 10,0 m

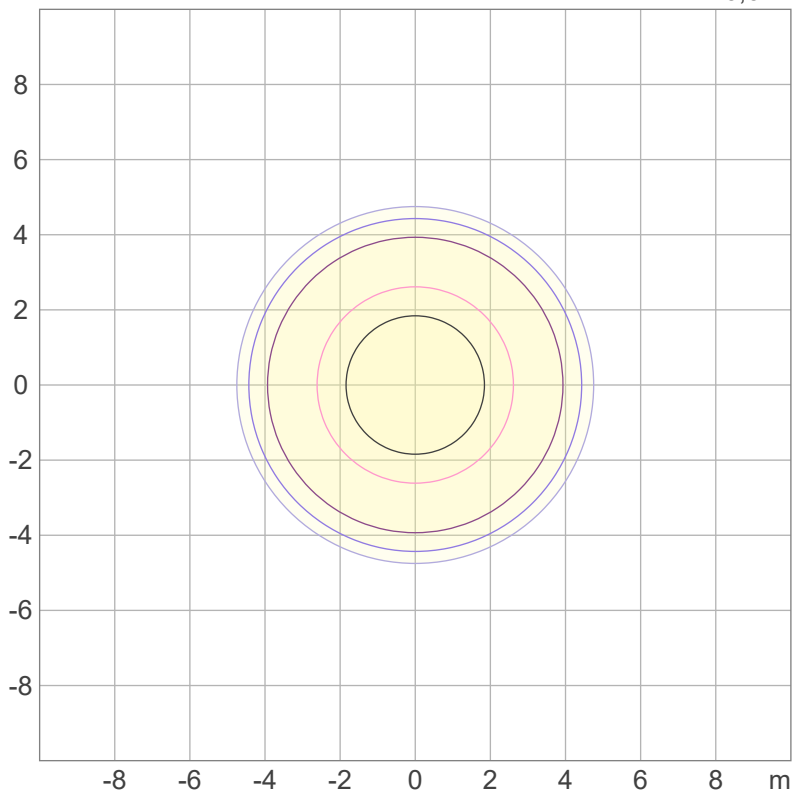

3%	1,71 lx
5%	2,85 lx
10%	5,71 lx
30%	17,1 lx
50%	28,5 lx

Conditions:

Number of c-planes: 2

Lux at center: 57,1 lx

*Lux distribution on a surface when lamp is mounted at 10 meters from the surface.*



Total lumen output:

568 lm

Peak candela output:

15175 cd

**PRODUCT NAME:**

**ECLFRCTPLIP**

**MEASURAMENT CONDITIONS:**

Beam angle:

Min Zoom

Target:

Red - HB

Operator:

Salvatore Giglio

Date and time:

03/10/2023 13:48:56

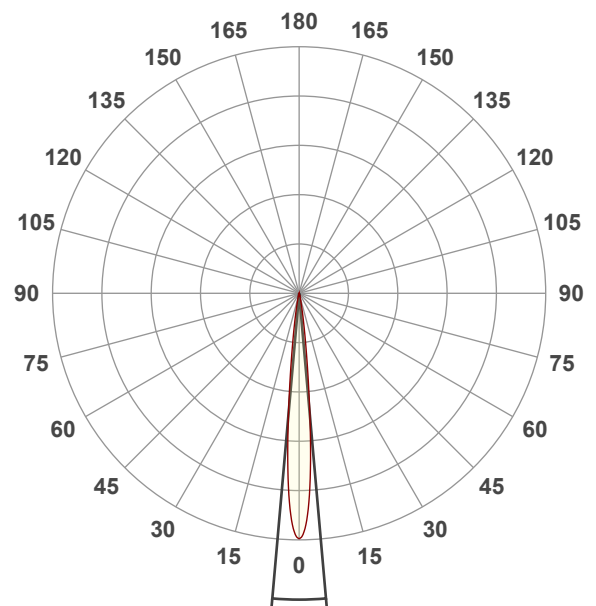

Beam angle 50%: 10,1°

Field angle 10%: 18,3°

Cut off angle 2.5%: 25,4°

Spectra

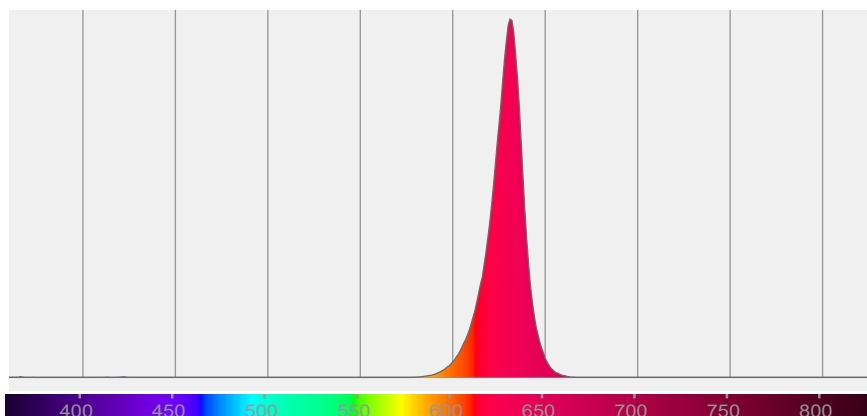

# BEAM DETAILS



Beam angle 50%	Field angle 10%	Cut off angle 2,5%	Intensity ratio in 120° cone	Intensity ratio in 90° cone
10,1°	18,3°	25,4°	100,0%	100,0%

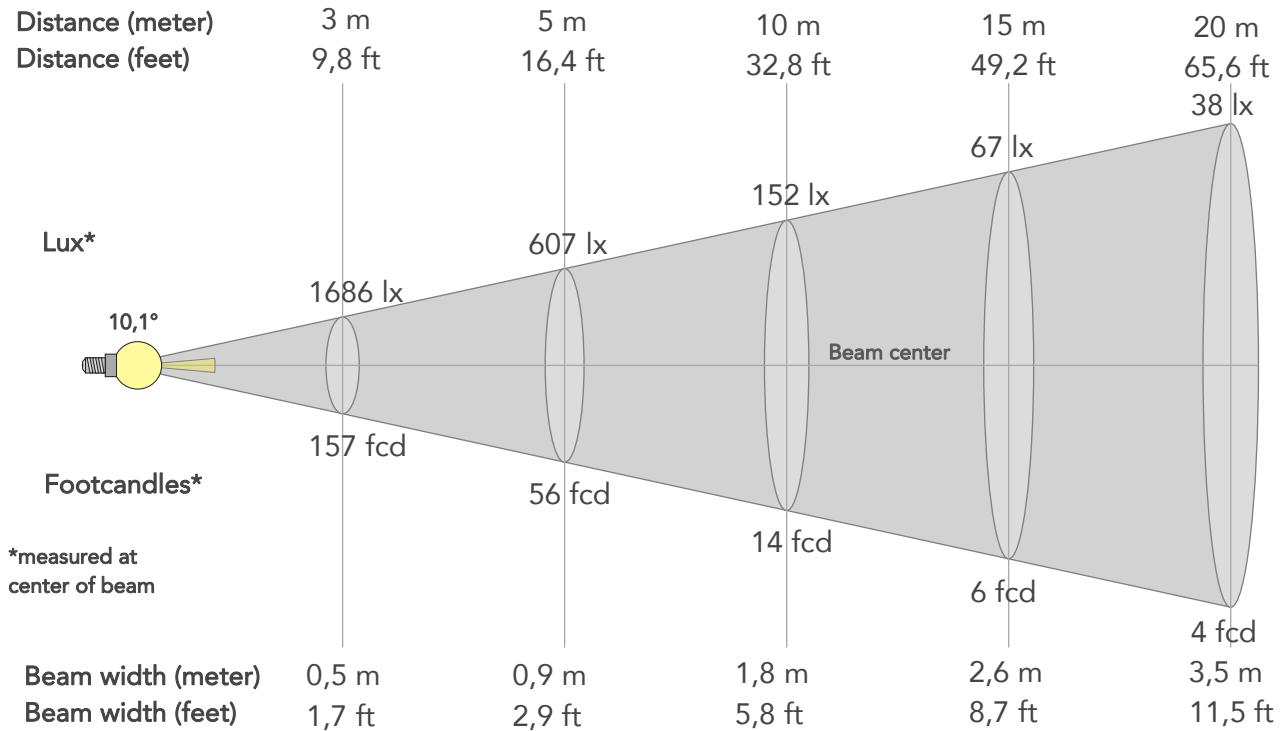

## BEAM INTENSITIES AND WIDTHS

Distance	1m	2m	3m	4m	5m	7,5m	10m	15m	20m	25m	30m	40m	50m
Distance	3,3ft	6,6ft	9,8ft	13,1ft	16,4ft	24,6ft	32,8ft	49,2ft	65,6ft	82ft	98,4ft	131,2ft	164ft
Lux	15175lx	3794lx	1686lx	948lx	607lx	270lx	152lx	67lx	38lx	24lx	17lx	9lx	6lx
Footcand.	1410fcd	352fcd	157fcd	88fcd	56fcd	25fcd	14fcd	6fcd	4fcd	2fcd	2fcd	1fcd	1fcd
Beam wid.	0,2m	0,4m	0,5m	0,7m	0,9m	1,3m	1,8m	2,6m	3,5m	4,4m	5,3m	7m	8,8m
Beam wid.	0,6ft	1,2ft	1,7ft	2,3ft	2,9ft	4,3ft	5,8ft	8,7ft	11,5ft	14,4ft	17,3ft	23,1ft	28,8ft

## LINEAR DISTRIBUTION DIAGRAM

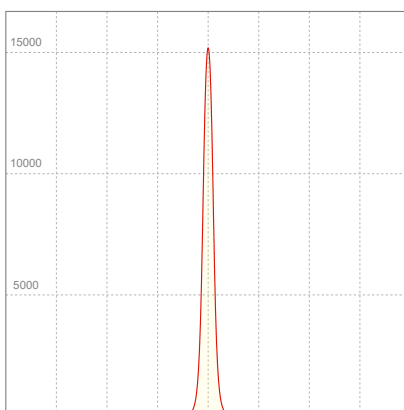

## ELECTRICAL SPECIFICATIONS

Input voltage	Input current	Input power	Effeciency
228V	0,485A	94,9W	6lm/W

Power FC
0,86

## ISO CANDELA DIAGRAM

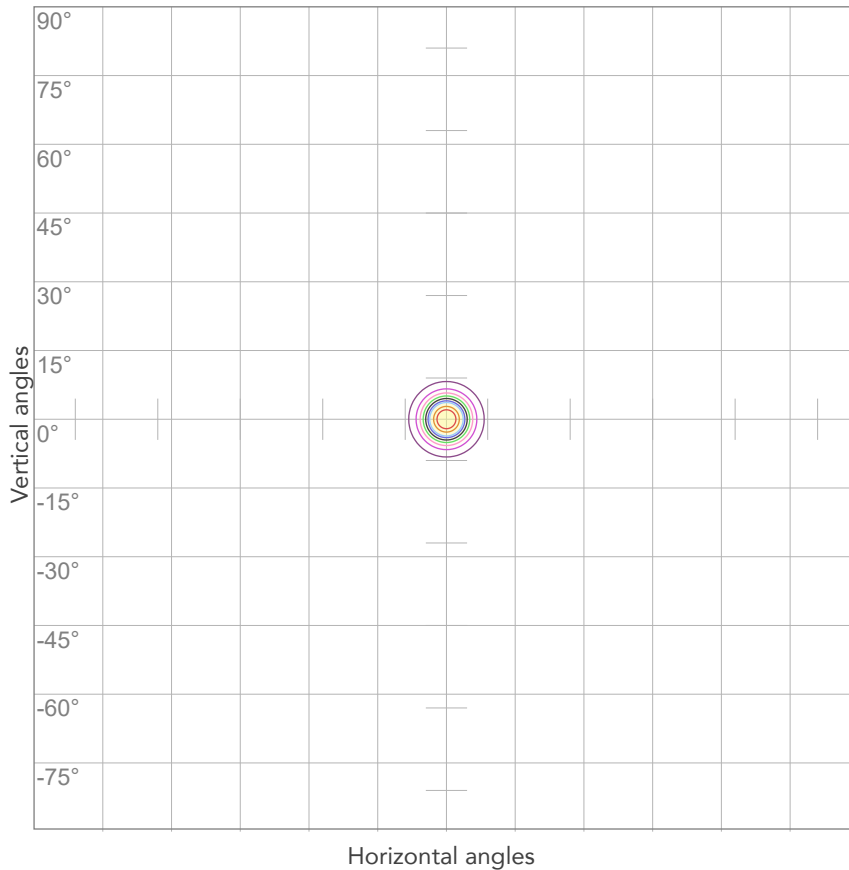

10%	1517 cd
20%	3035 cd
30%	4552 cd
40%	6070 cd
50%	7587 cd
60%	9105 cd
70%	10622 cd
80%	12140 cd

Conditions:

Number of c-planes: 2

Candela at center: 15175 cd

## ISO LUX DIAGRAM

MH: 10,0 m

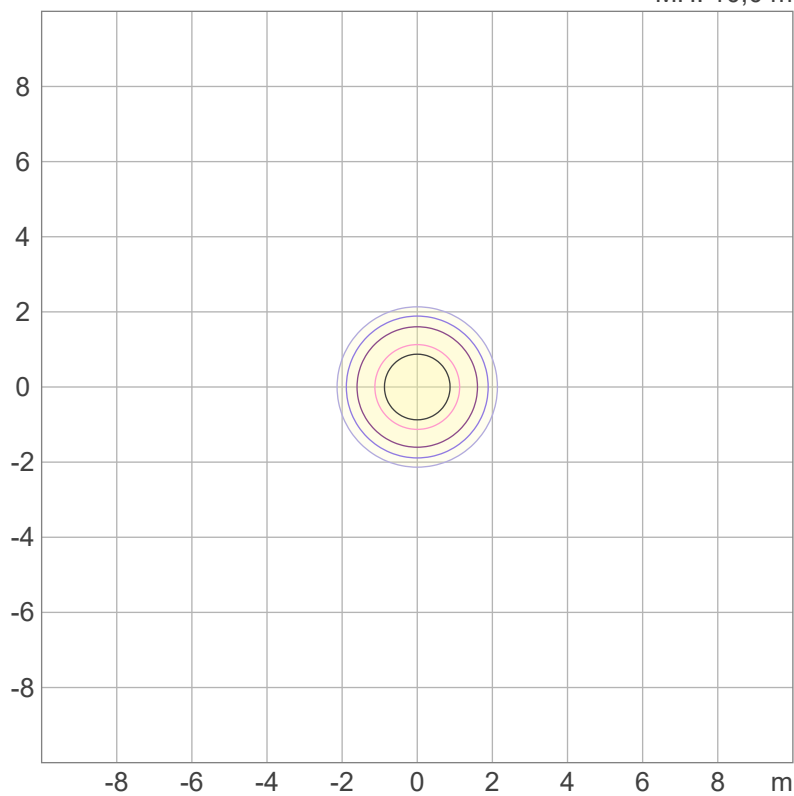

3%	4,55 lx
5%	7,59 lx
10%	15,2 lx
30%	45,5 lx
50%	75,9 lx

Conditions:

Number of c-planes: 2

Lux at center: 152 lx

*Lux distribution on a surface when lamp is mounted at 10 meters from the surface.*



Total lumen output:

2186 lm

Peak candela output:

2766 cd

**PRODUCT NAME:**  
**ECLFRCTPLIP**

**MEASURAMENT CONDITIONS:**

Beam angle:

Max Zoom

Target:

Green - HB

Operator:

Salvatore Giglio

Date and time:

03/10/2023 13:19:12

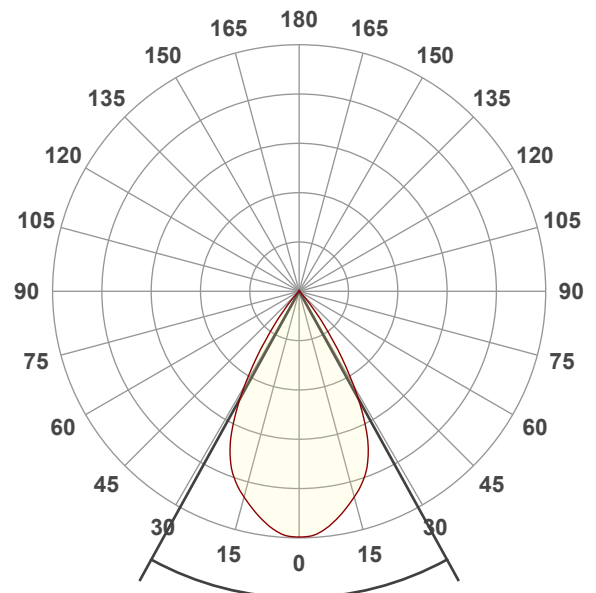

Beam angle 50%: 57,7°

Field angle 10%: 77,9°

Cut off angle 2.5%: 86,6°

Spectra

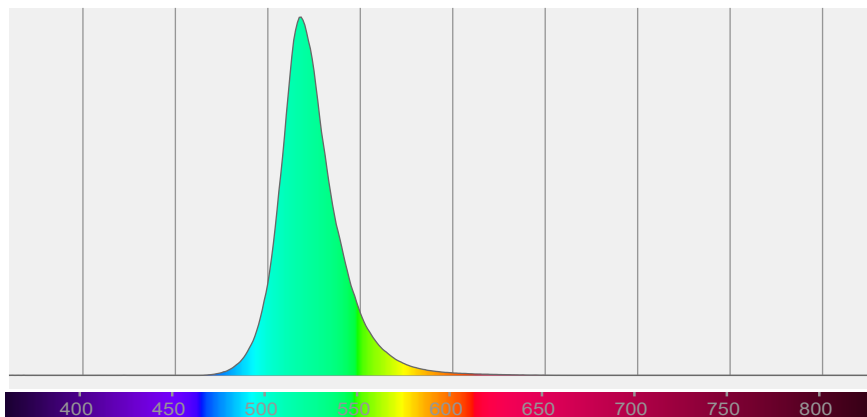

# BEAM DETAILS



Beam angle 50%	Field angle 10%	Cut off angle 2,5%	Intensity ratio in 120° cone	Intensity ratio in 90° cone
57,7°	77,9°	86,6°	100,0%	99,5%

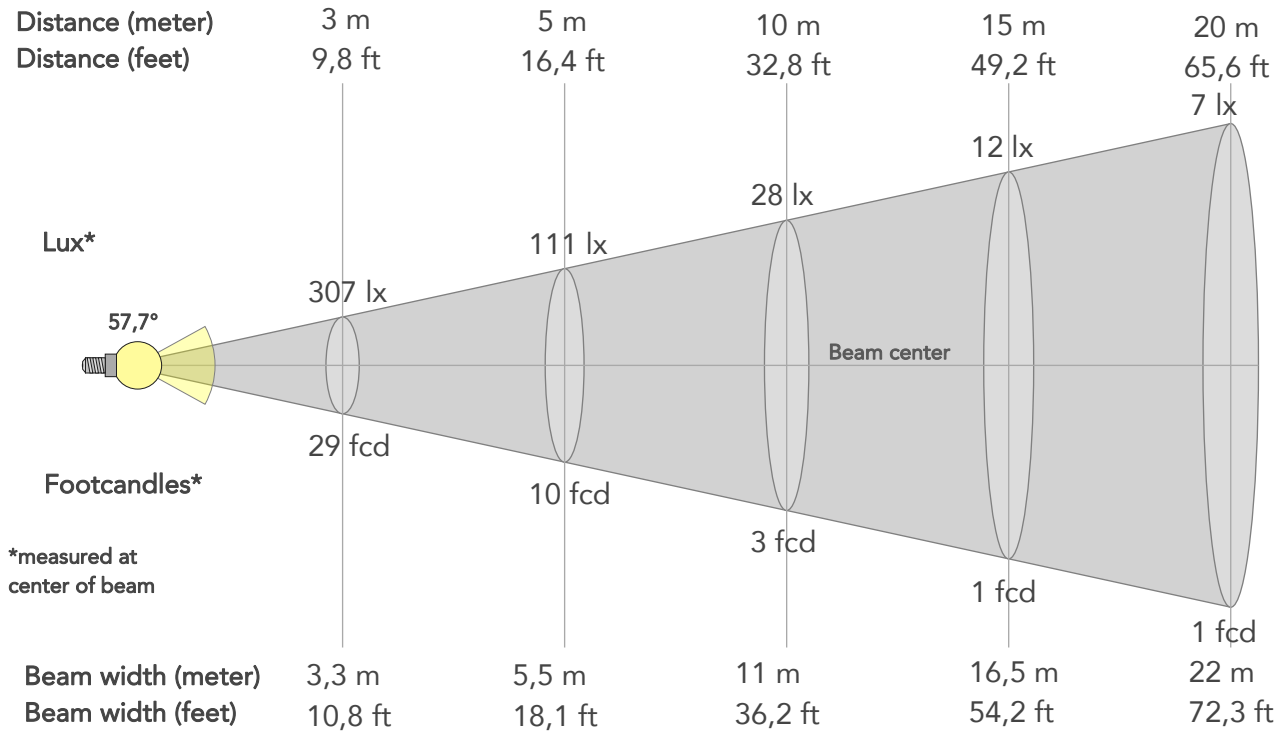

## BEAM INTENSITIES AND WIDTHS

Distance	1m	2m	3m	4m	5m	7,5m	10m	15m	20m	25m	30m	40m	50m
Distance	3,3ft	6,6ft	9,8ft	13,1ft	16,4ft	24,6ft	32,8ft	49,2ft	65,6ft	82ft	98,4ft	131,2ft	164ft
Lux	2766lx	691lx	307lx	173lx	111lx	49lx	28lx	12lx	7lx	4lx	3lx	2lx	1lx
Footcand.	257fcd	64fcd	29fcd	16fcd	10fcd	5fcd	3fcd	1fcd	1fcd	0fcd	0fcd	0fcd	0fcd
Beam wid.	1,1m	2,2m	3,3m	4,4m	5,5m	8,3m	11m	16,5m	22m	27,6m	33,1m	44,1m	55,1m
Beam wid.	3,6ft	7,3ft	10,8ft	14,4ft	18,1ft	27,1ft	36,2ft	54,2ft	72,3ft	90,4ft	108,5ft	144,6ft	180,8ft

## LINEAR DISTRIBUTION DIAGRAM

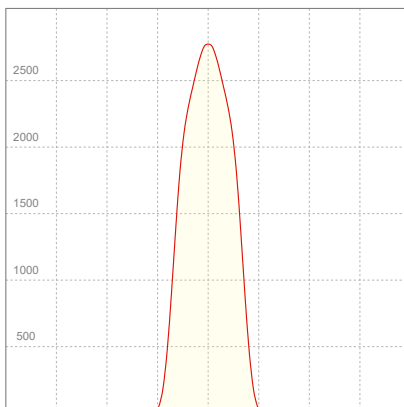

## ELECTRICAL SPECIFICATIONS

Input voltage	Input current	Input power	Effeciency
229V	0,485A	94,6W	23lm/W

Power FC
0,85



## ISO CANDELA DIAGRAM

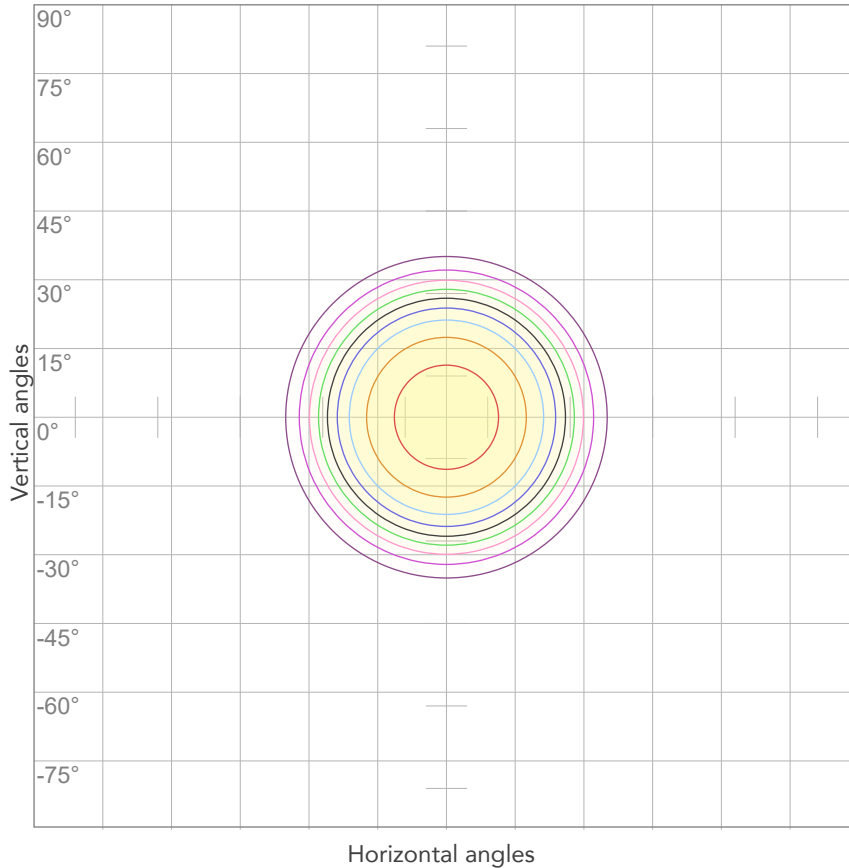

10%	277 cd
20%	553 cd
30%	830 cd
40%	1106 cd
50%	1383 cd
60%	1660 cd
70%	1936 cd
80%	2213 cd

Conditions:

Number of c-planes: 2

Candela at center: 2766 cd

## ISO LUX DIAGRAM

MH: 10,0 m

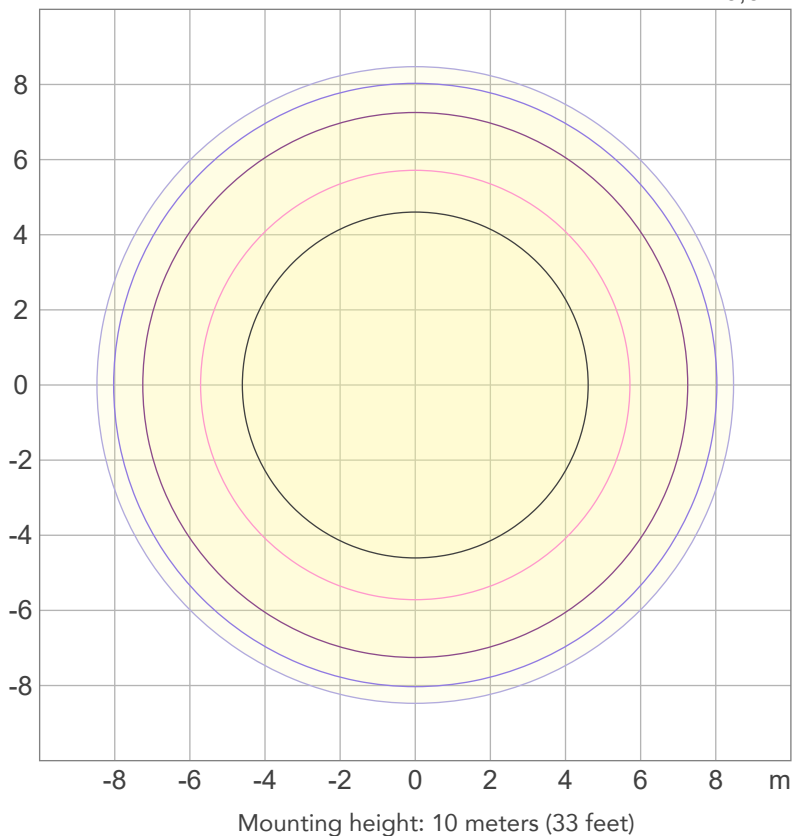

3%	0,830 lx
5%	1,38 lx
10%	2,77 lx
30%	8,30 lx
50%	13,8 lx

Conditions:

Number of c-planes: 2

Lux at center: 27,7 lx

*Lux distribution on a surface when lamp is mounted at 10 meters from the surface.*



Total lumen output:

1729 lm

Peak candela output:

9054 cd

**PRODUCT NAME:**  
**ECLFRCTPLIP**

**MEASURAMENT CONDITIONS:**

Beam angle:  
Med Zoom

Target:  
Green - HB

Operator:  
Salvatore Giglio

Date and time:  
03/10/2023 14:46:35

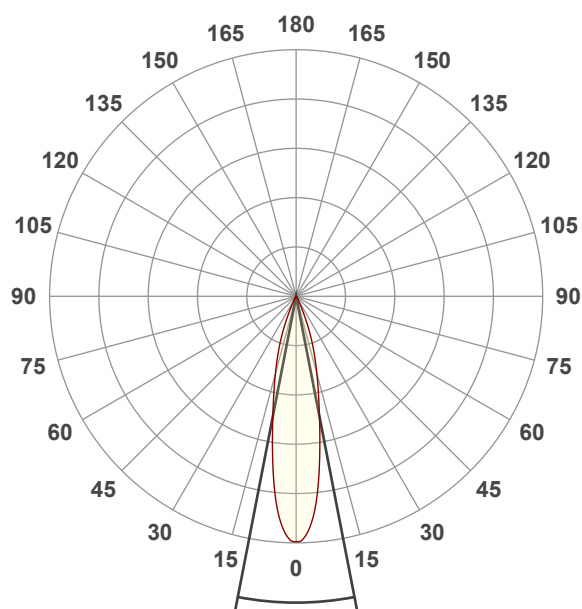

Beam angle 50%: 22°  
Field angle 10%: 45,1°  
Cut off angle 2.5%: 53,6°

Spectra

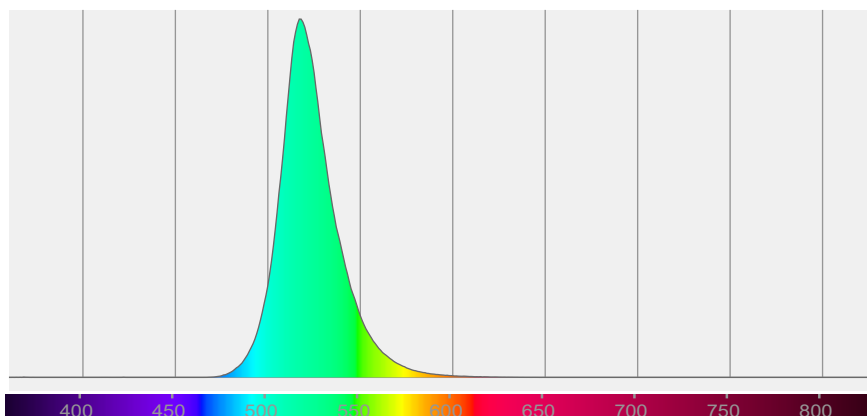

# BEAM DETAILS



Beam angle 50%	Field angle 10%	Cut off angle 2,5%	Intensity ratio in 120° cone	Intensity ratio in 90° cone
22°	45,1°	53,6°	100,0%	100,0%

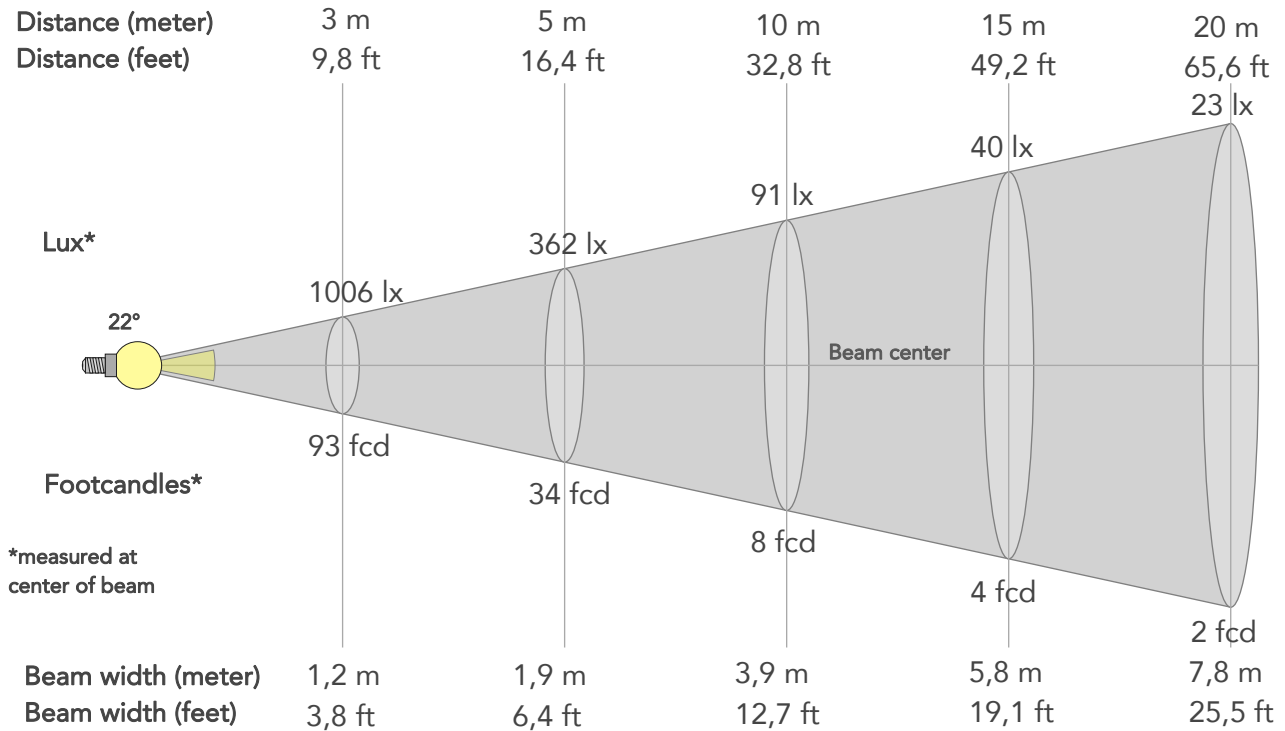

## BEAM INTENSITIES AND WIDTHS

Distance	1m	2m	3m	4m	5m	7,5m	10m	15m	20m	25m	30m	40m	50m
Distance	3,3ft	6,6ft	9,8ft	13,1ft	16,4ft	24,6ft	32,8ft	49,2ft	65,6ft	82ft	98,4ft	131,2ft	164ft
Lux	9054lx	2263lx	1006lx	566lx	362lx	161lx	91lx	40lx	23lx	14lx	10lx	6lx	4lx
Footcand.	841fcd	210fcd	93fcd	53fcd	34fcd	15fcd	8fcd	4fcd	2fcd	1fcd	1fcd	1fcd	0fcd
Beam wid.	0,4m	0,8m	1,2m	1,6m	1,9m	2,9m	3,9m	5,8m	7,8m	9,7m	11,6m	15,5m	19,4m
Beam wid.	1,3ft	2,6ft	3,8ft	5,1ft	6,4ft	9,5ft	12,7ft	19,1ft	25,5ft	31,8ft	38,2ft	50,9ft	63,6ft

## LINEAR DISTRIBUTION DIAGRAM

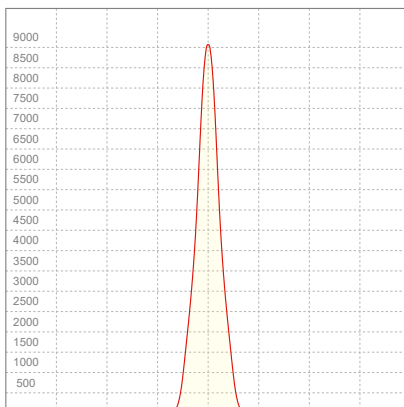

## ELECTRICAL SPECIFICATIONS

Input voltage	Input current	Input power	Effeciency
228V	0,485A	94,3W	18lm/W

Power FC
0,85

## ISO CANDELA DIAGRAM

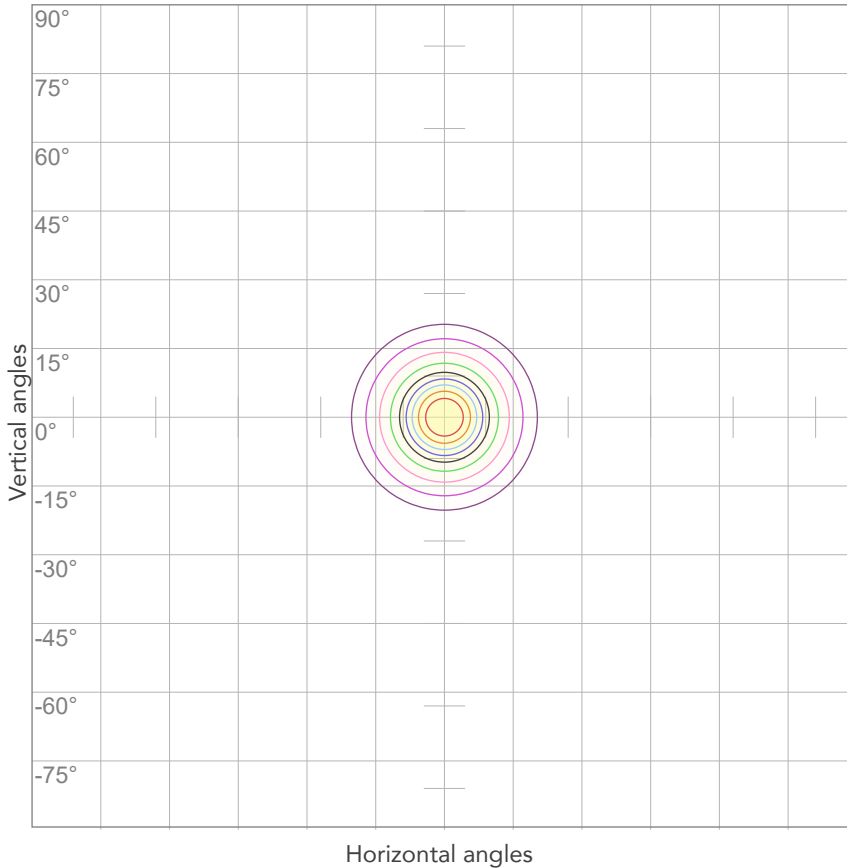

10%	905 cd
20%	1811 cd
30%	2716 cd
40%	3621 cd
50%	4527 cd
60%	5432 cd
70%	6338 cd
80%	7243 cd

Conditions:

Number of c-planes: 2

Candela at center: 9054 cd

## ISO LUX DIAGRAM

MH: 10,0 m

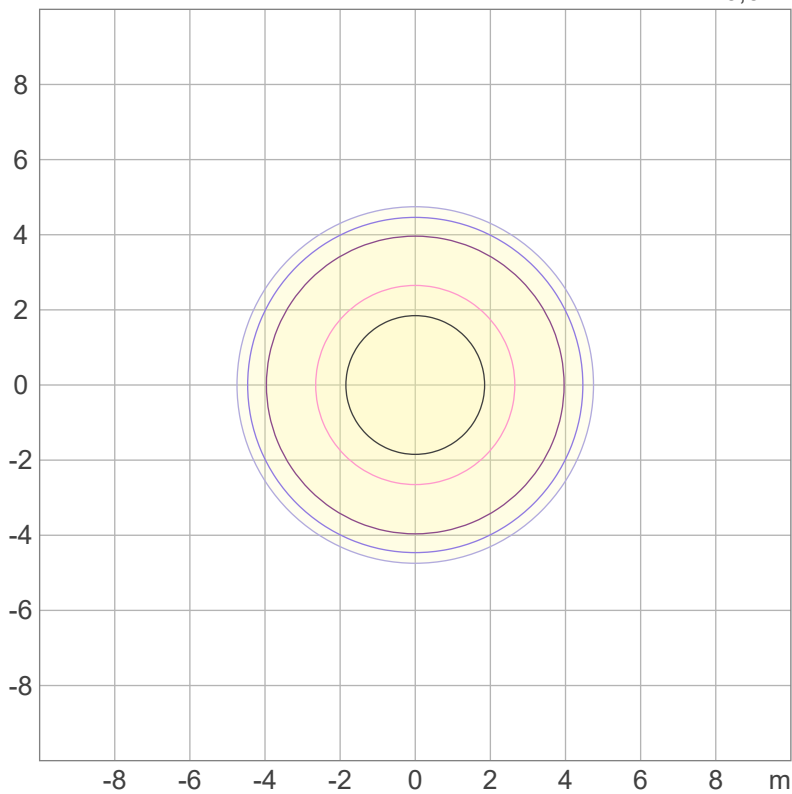

Mounting height: 10 meters (33 feet)

3%	2,72 lx
5%	4,53 lx
10%	9,05 lx
30%	27,2 lx
50%	45,3 lx

Conditions:

Number of c-planes: 2

Lux at center: 90,5 lx

*Lux distribution on a surface when lamp is mounted at 10 meters from the surface.*



Total lumen output:

895 lm

Peak candela output:

23762 cd

**PRODUCT NAME:**  
**ECLFRCTPLIP**

**MEASURAMENT CONDITIONS:**

Beam angle:

Min Zoom

Target:

Green - HB

Operator:

Salvatore Giglio

Date and time:

03/10/2023 13:50:14

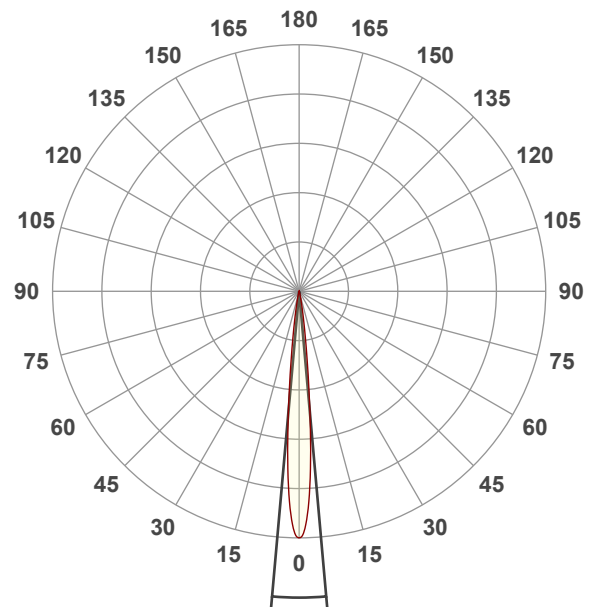

Beam angle 50%: 10,1°

Field angle 10%: 18,6°

Cut off angle 2.5%: 25,6°

Spectra

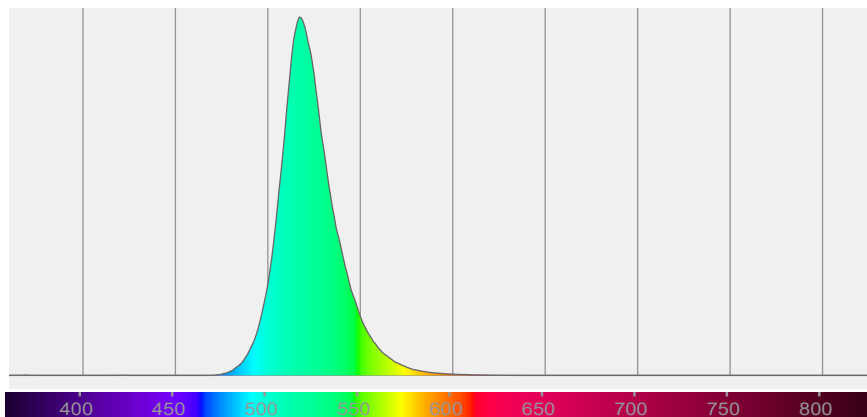

# BEAM DETAILS



Beam angle 50%	Field angle 10%	Cut off angle 2,5%	Intensity ratio in 120° cone	Intensity ratio in 90° cone
10,1°	18,6°	25,6°	100,0%	100,0%

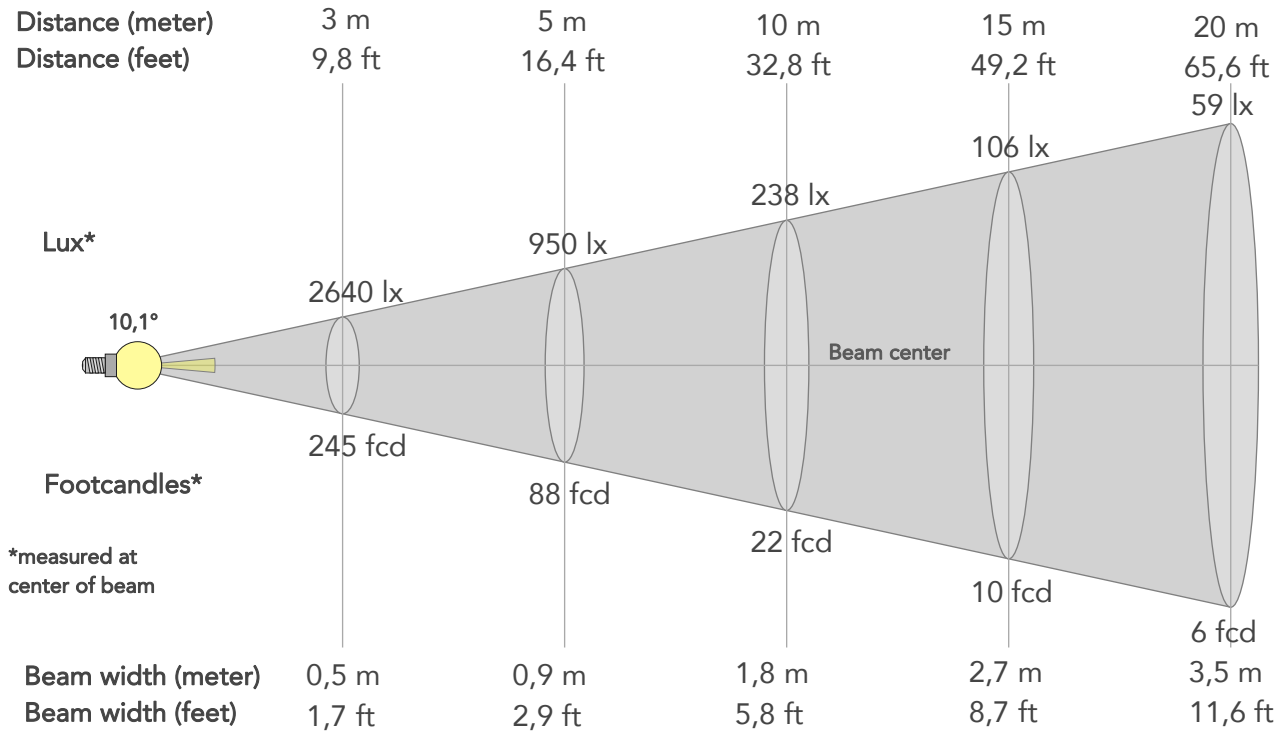

## BEAM INTENSITIES AND WIDTHS

Distance	1m	2m	3m	4m	5m	7,5m	10m	15m	20m	25m	30m	40m	50m
Distance	3,3ft	6,6ft	9,8ft	13,1ft	16,4ft	24,6ft	32,8ft	49,2ft	65,6ft	82ft	98,4ft	131,2ft	164ft
Lux	23762lx	5940lx	2640lx	1485lx	950lx	422lx	238lx	106lx	59lx	38lx	26lx	15lx	10lx
Footcand.	2208fcd	552fcd	245fcd	138fcd	88fcd	39fcd	22fcd	10fcd	6fcd	4fcd	2fcd	1fcd	1fcd
Beam wid.	0,2m	0,4m	0,5m	0,7m	0,9m	1,3m	1,8m	2,7m	3,5m	4,4m	5,3m	7,1m	8,9m
Beam wid.	0,6ft	1,2ft	1,7ft	2,3ft	2,9ft	4,4ft	5,8ft	8,7ft	11,6ft	14,6ft	17,5ft	23,3ft	29,1ft

## LINEAR DISTRIBUTION DIAGRAM

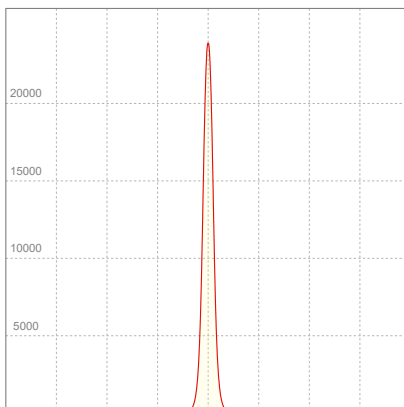

## ELECTRICAL SPECIFICATIONS

Input voltage	Input current	Input power	Effeciency
227V	0,487A	95,0W	9lm/W

Power FC
0,86

## ISO CANDELA DIAGRAM

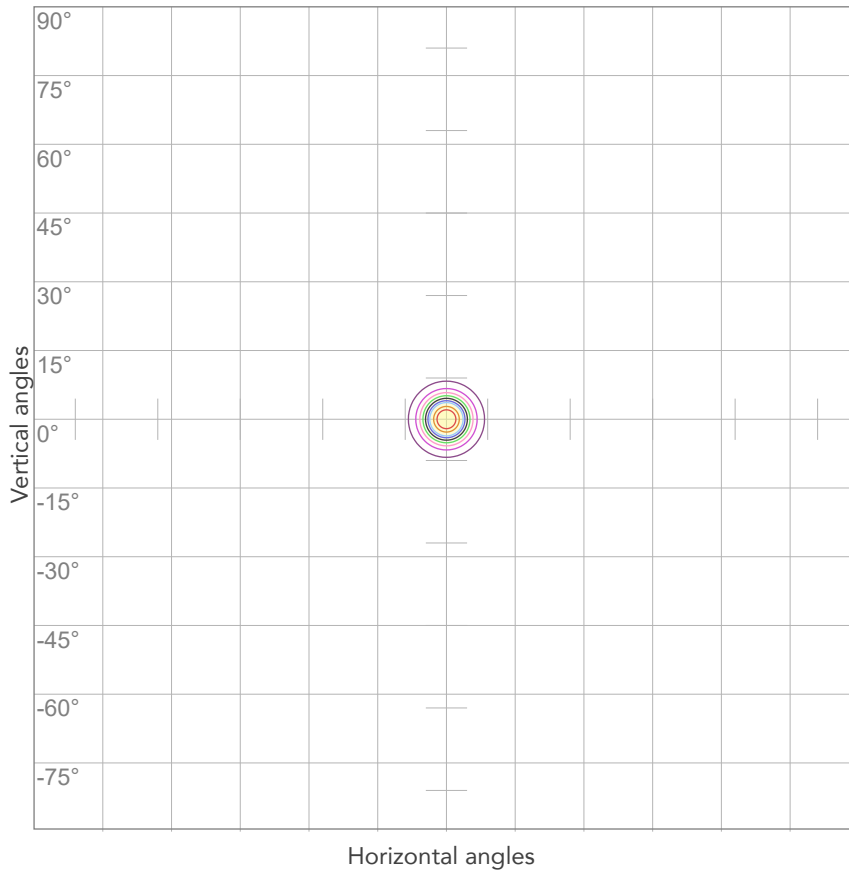

10%	2376 cd
20%	4752 cd
30%	7128 cd
40%	9505 cd
50%	11881 cd
60%	14257 cd
70%	16633 cd
80%	19009 cd

Conditions:

Number of c-planes: 2

Candela at center: 23762 cd

## ISO LUX DIAGRAM

MH: 10,0 m

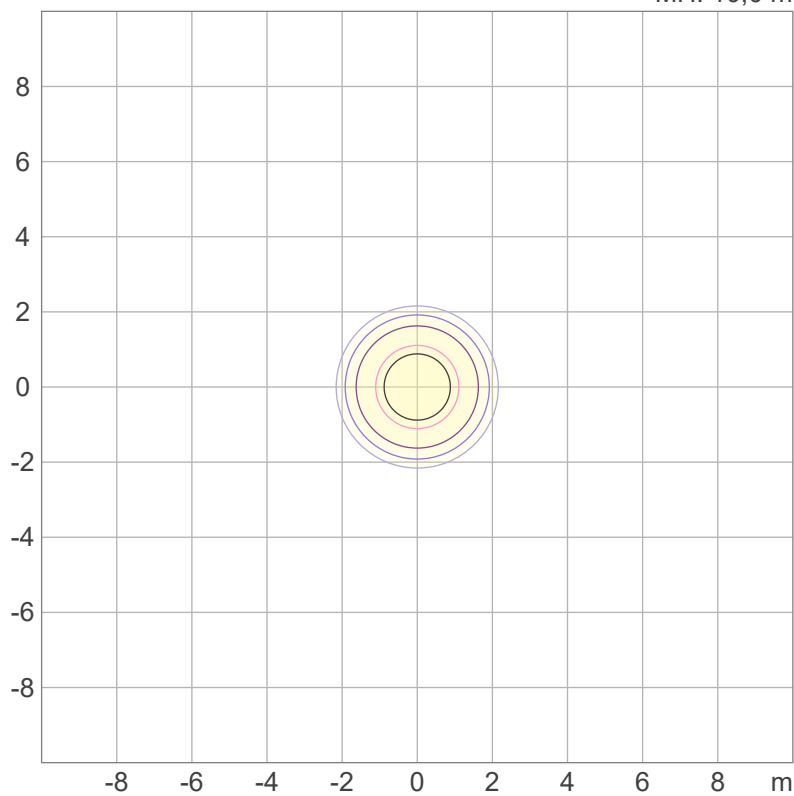

3%	7,13 lx
5%	11,9 lx
10%	23,8 lx
30%	71,3 lx
50%	119 lx

Conditions:

Number of c-planes: 2

Lux at center: 238 lx

*Lux distribution on a surface when lamp is mounted at 10 meters from the surface.*



Total lumen output:

410 lm

Peak candela output:

521 cd

**PRODUCT NAME:**  
**ECLFRCTPLIP**

**MEASURAMENT CONDITIONS:**

Beam angle:  
Max Zoom

Target:  
Blue - HB

Operator:  
Salvatore Giglio

Date and time:  
03/10/2023 13:20:40

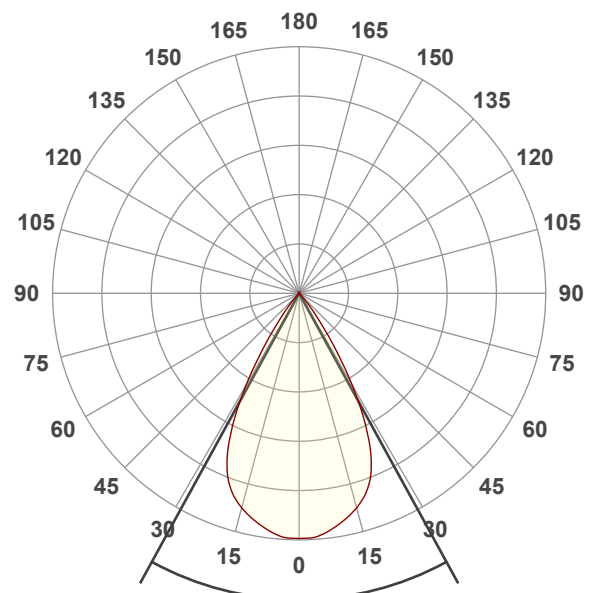

Beam angle 50%: 57,5°  
Field angle 10%: 75,8°  
Cut off angle 2.5%: 84,8°

Spectra

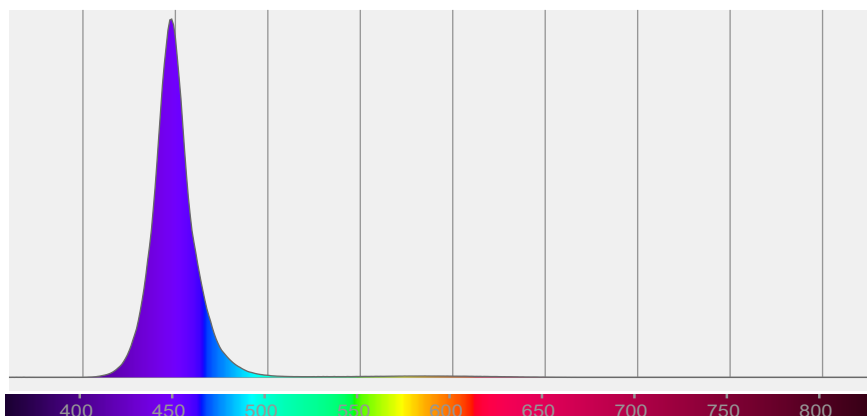



# BEAM DETAILS



Beam angle 50%	Field angle 10%	Cut off angle 2,5%	Intensity ratio in 120° cone	Intensity ratio in 90° cone
57,5°	75,8°	84,8°	99,9%	99,5%

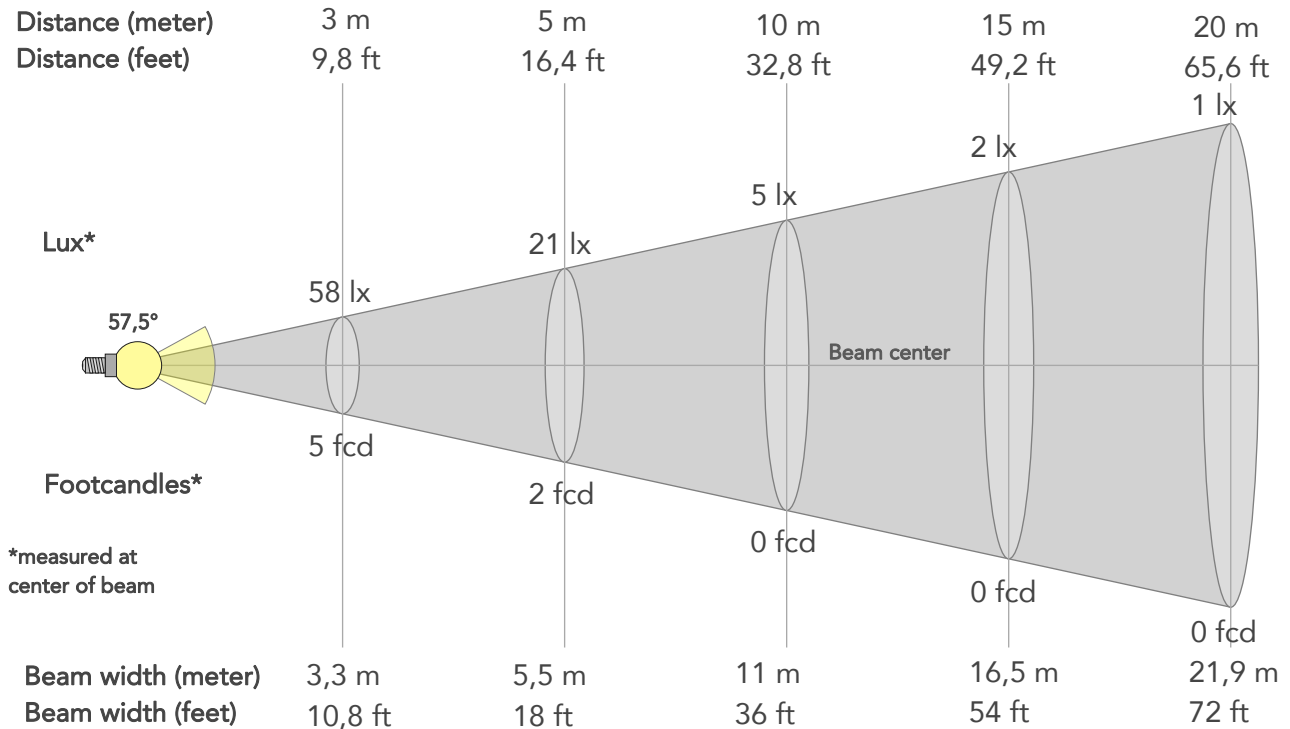

## BEAM INTENSITIES AND WIDTHS

Distance	1m	2m	3m	4m	5m	7,5m	10m	15m	20m	25m	30m	40m	50m
Distance	3,3ft	6,6ft	9,8ft	13,1ft	16,4ft	24,6ft	32,8ft	49,2ft	65,6ft	82ft	98,4ft	131,2ft	164ft
Lux	521lx	130lx	58lx	33lx	21lx	9lx	5lx	2lx	1lx	1lx	1lx	0lx	0lx
Footcand.	48fcd	12fcd	5fcd	3fcd	2fcd	1fcd	0fcd	0fcd	0fcd	0fcd	0fcd	0fcd	0fcd
Beam wid.	1,1m	2,2m	3,3m	4,4m	5,5m	8,2m	11m	16,5m	21,9m	27,4m	32,9m	43,9m	54,8m
Beam wid.	3,6ft	7,2ft	10,8ft	14,4ft	18ft	27ft	36ft	54ft	72ft	90ft	107,9ft	143,9ft	179,9ft

## LINEAR DISTRIBUTION DIAGRAM

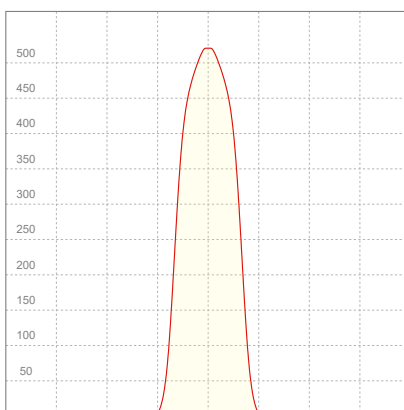

## ELECTRICAL SPECIFICATIONS

Input voltage	Input current	Input power	Effeciency
229V	0,505A	100,8W	4lm/W

Power FC
0,87

## ISO CANDELA DIAGRAM

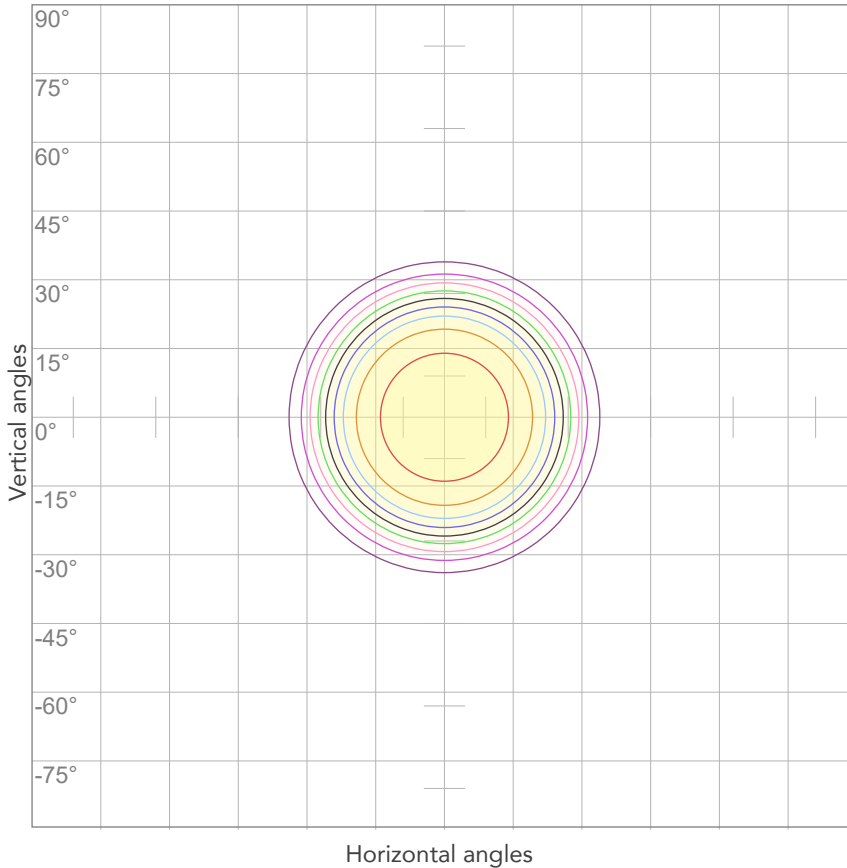

10%	52 cd
20%	104 cd
30%	156 cd
40%	208 cd
50%	260 cd
60%	312 cd
70%	364 cd
80%	417 cd

Conditions:

Number of c-planes: 2  
Candela at center: 521 cd

## ISO LUX DIAGRAM

MH: 10,0 m

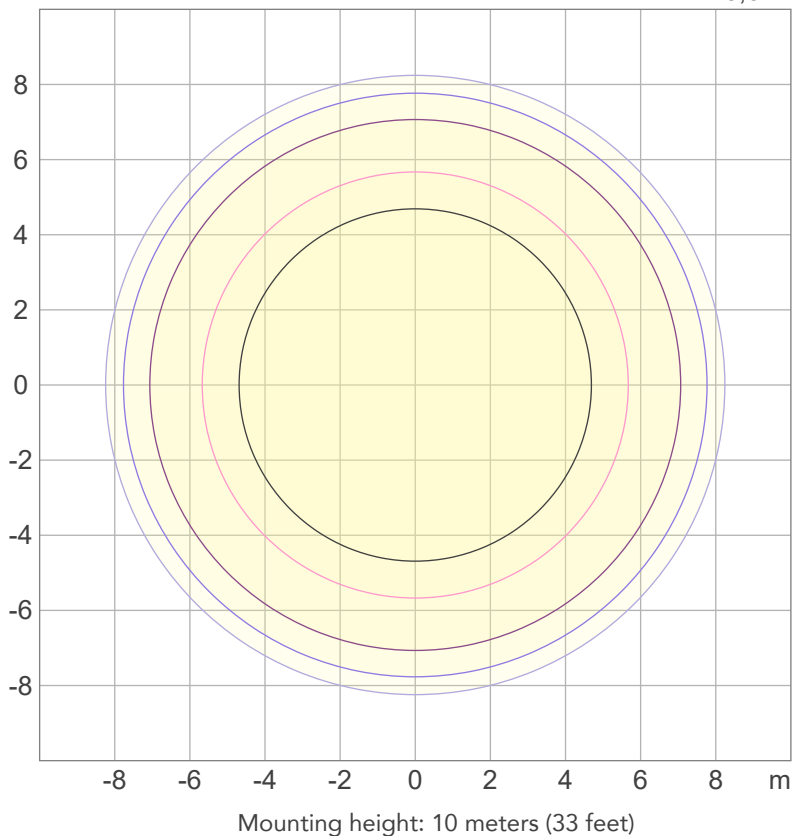

3%	0,156 lx
5%	0,260 lx
10%	0,521 lx
30%	1,56 lx
50%	2,60 lx

Conditions:

Number of c-planes: 2  
Lux at center: 5,21 lx

*Lux distribution on a surface when lamp is mounted at 10 meters from the surface.*



Total lumen output:

314 lm

Peak candela output:

1738 cd

**PRODUCT NAME:**  
**ECLFRCTPLIP**

**MEASURAMENT CONDITIONS:**

Beam angle:  
Med Zoom

Target:  
Blue - HB

Operator:  
Salvatore Giglio

Date and time:  
03/10/2023 14:48:28

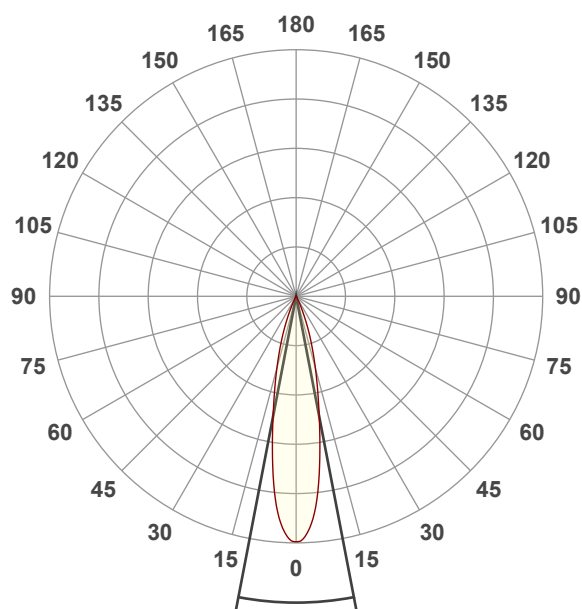

Beam angle 50%: 21,7°  
Field angle 10%: 43,3°  
Cut off angle 2.5%: 52,7°

Spectra

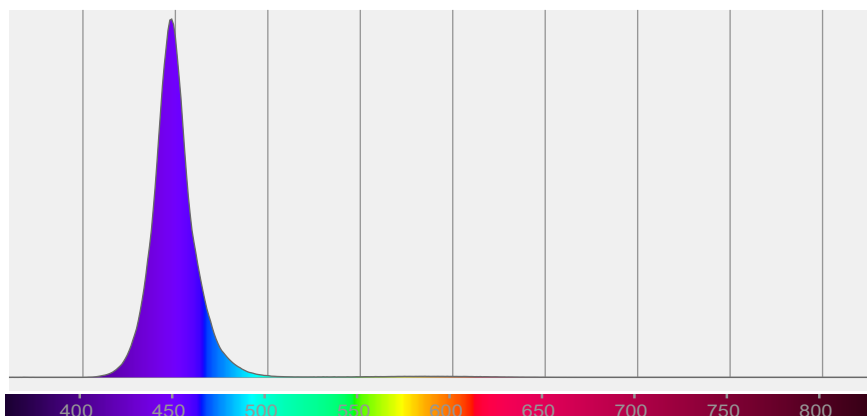

# BEAM DETAILS



Beam angle 50%	Field angle 10%	Cut off angle 2,5%	Intensity ratio in 120° cone	Intensity ratio in 90° cone
21,7°	43,3°	52,7°	100,0%	99,9%

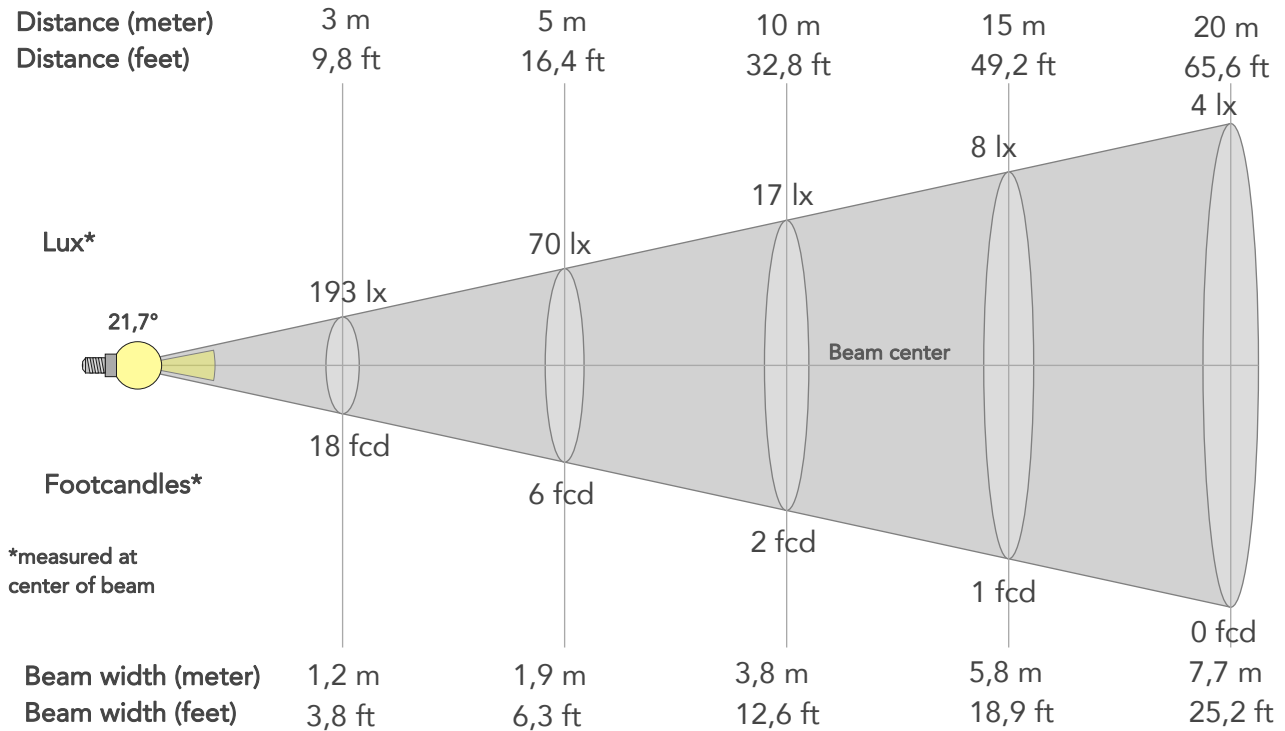

## BEAM INTENSITIES AND WIDTHS

Distance	1m	2m	3m	4m	5m	7,5m	10m	15m	20m	25m	30m	40m	50m
Distance	3,3ft	6,6ft	9,8ft	13,1ft	16,4ft	24,6ft	32,8ft	49,2ft	65,6ft	82ft	98,4ft	131,2ft	164ft
Lux	1738lx	434lx	193lx	109lx	70lx	31lx	17lx	8lx	4lx	3lx	2lx	1lx	1lx
Footcand.	161fcd	40fcd	18fcd	10fcd	6fcd	3fcd	2fcd	1fcd	0fcd	0fcd	0fcd	0fcd	0fcd
Beam wid.	0,4m	0,8m	1,2m	1,5m	1,9m	2,9m	3,8m	5,8m	7,7m	9,6m	11,5m	15,4m	19,2m
Beam wid.	1,3ft	2,5ft	3,8ft	5ft	6,3ft	9,4ft	12,6ft	18,9ft	25,2ft	31,5ft	37,8ft	50,4ft	62,9ft

## LINEAR DISTRIBUTION DIAGRAM

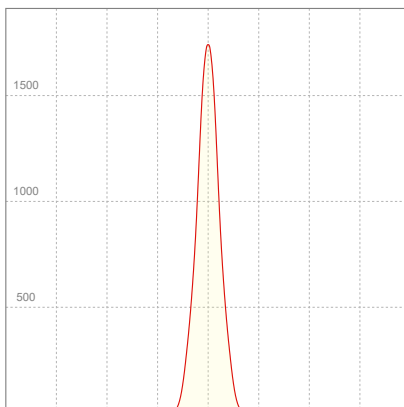

## ELECTRICAL SPECIFICATIONS

Input voltage	Input current	Input power	Effeciency
228V	0,504A	100,6W	3lm/W

Power FC
0,88

## ISO CANDELA DIAGRAM

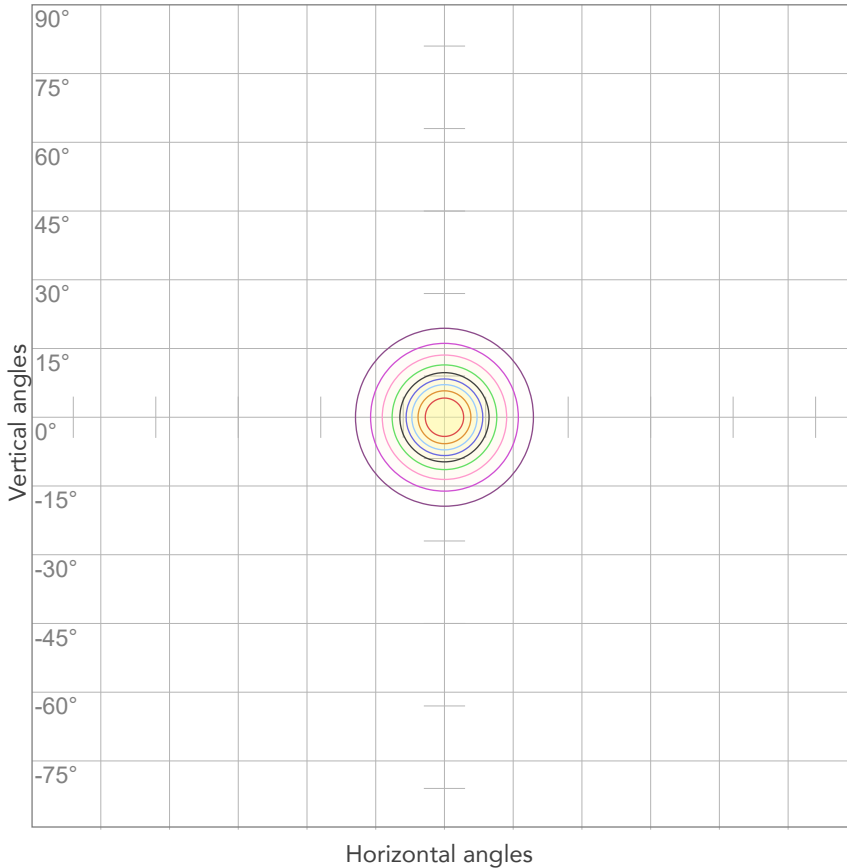

10%	174 cd
20%	348 cd
30%	521 cd
40%	695 cd
50%	869 cd
60%	1043 cd
70%	1216 cd
80%	1390 cd

Conditions:

Number of c-planes: 2

Candela at center: 1738 cd

## ISO LUX DIAGRAM

MH: 10,0 m

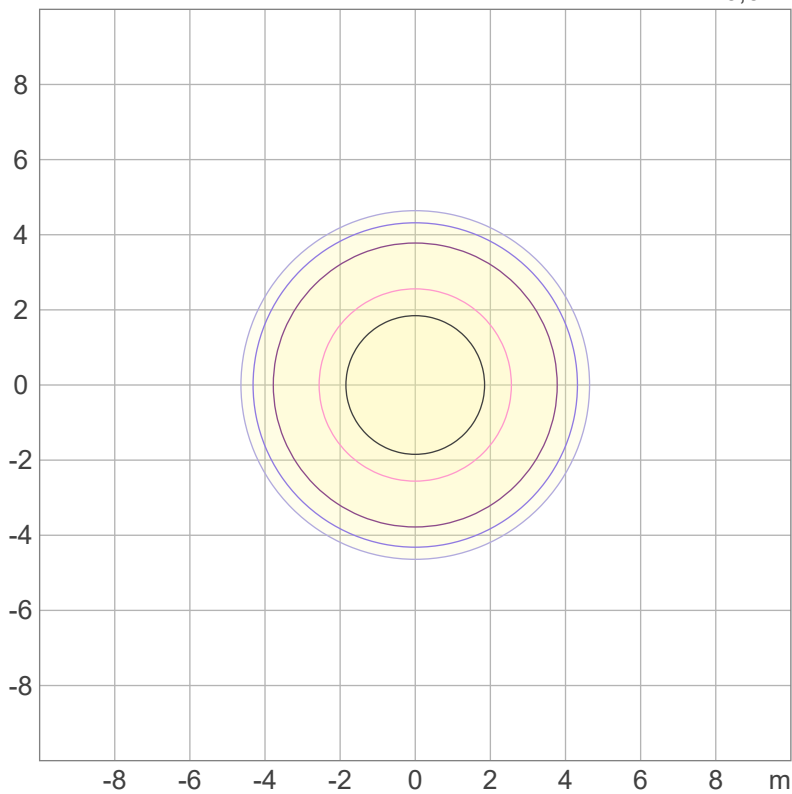

3%	0,521 lx
5%	0,869 lx
10%	1,74 lx
30%	5,21 lx
50%	8,69 lx

Conditions:

Number of c-planes: 2

Lux at center: 17,4 lx

*Lux distribution on a surface when lamp is mounted at 10 meters from the surface.*



Total lumen output:

173 lm

Peak candela output:

4683 cd

**PRODUCT NAME:**  
**ECLFRCTPLIP**

**MEASURAMENT CONDITIONS:**

Beam angle:

Min Zoom

Target:

Blue - HB

Operator:

Salvatore Giglio

Date and time:

03/10/2023 13:51:44

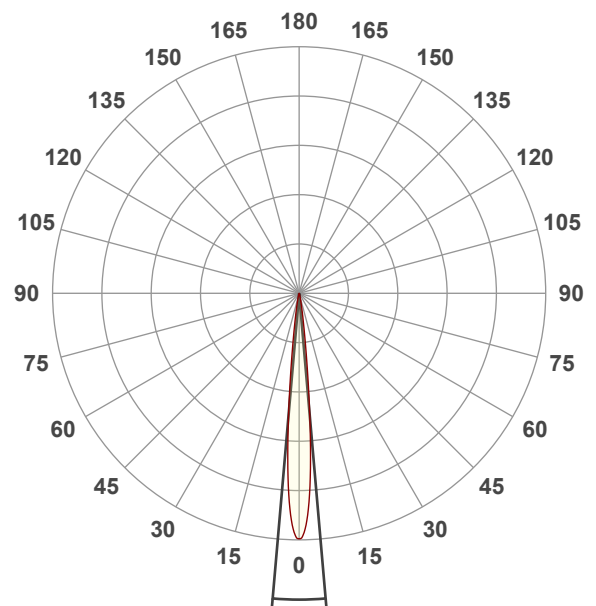

Beam angle 50%: 9,9°  
Field angle 10%: 17,6°  
Cut off angle 2.5%: 25°

Spectra

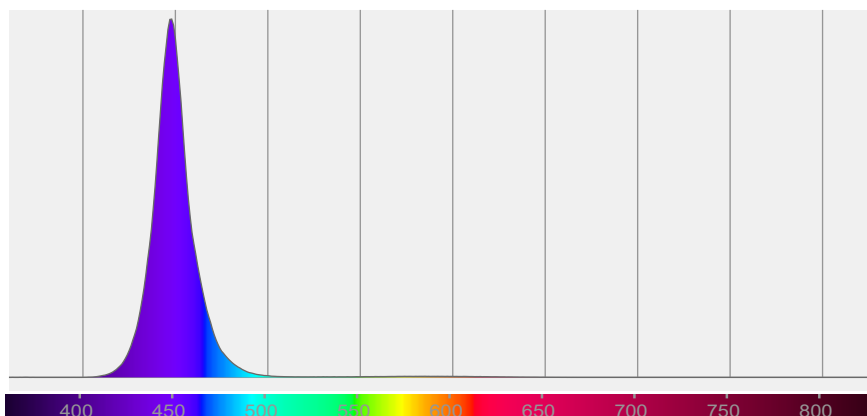

# BEAM DETAILS



Beam angle 50%	Field angle 10%	Cut off angle 2,5%	Intensity ratio in 120° cone	Intensity ratio in 90° cone
9,9°	17,6°	25°	100,0%	99,9%

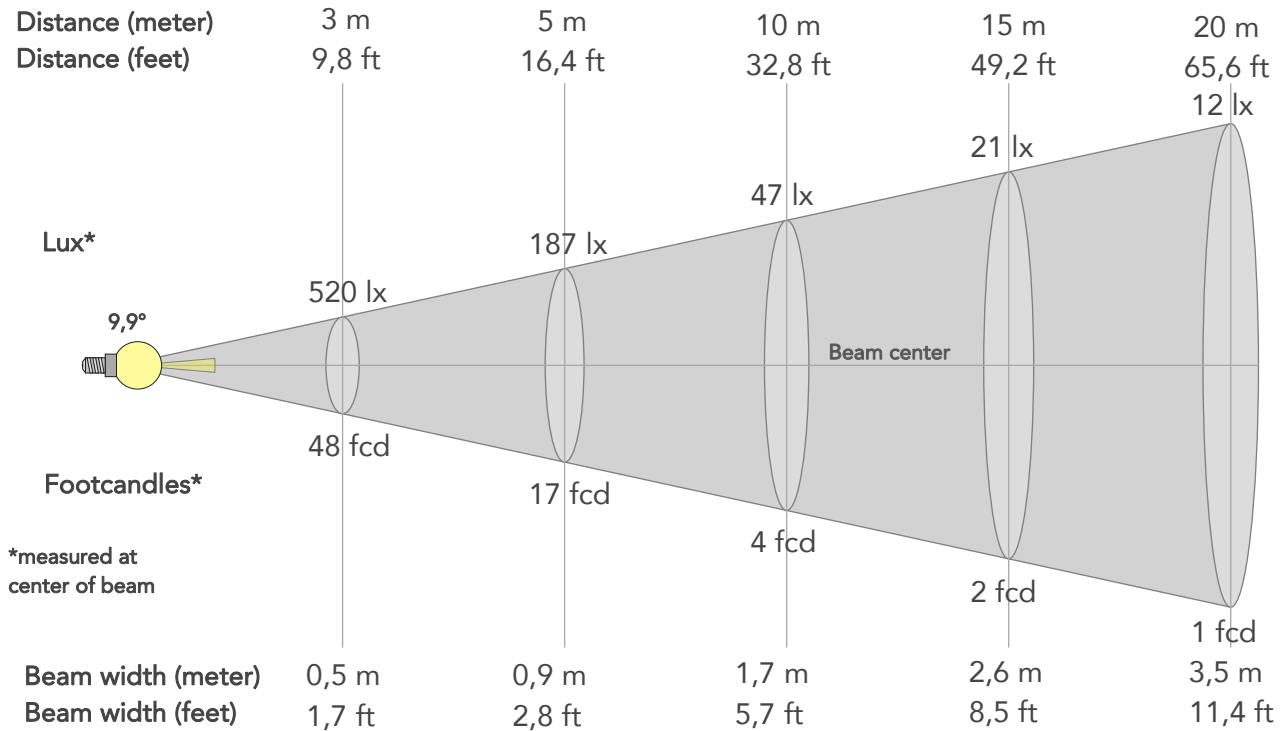

## BEAM INTENSITIES AND WIDTHS

Distance	1m	2m	3m	4m	5m	7,5m	10m	15m	20m	25m	30m	40m	50m
Distance	3,3ft	6,6ft	9,8ft	13,1ft	16,4ft	24,6ft	32,8ft	49,2ft	65,6ft	82ft	98,4ft	131,2ft	164ft
Lux	4683lx	1171lx	520lx	293lx	187lx	83lx	47lx	21lx	12lx	7lx	5lx	3lx	2lx
Footcand.	435fcd	109fcd	48fcd	27fcd	17fcd	8fcd	4fcd	2fcd	1fcd	1fcd	0fcd	0fcd	0fcd
Beam wid.	0,2m	0,3m	0,5m	0,7m	0,9m	1,3m	1,7m	2,6m	3,5m	4,3m	5,2m	6,9m	8,7m
Beam wid.	0,6ft	1,1ft	1,7ft	2,3ft	2,8ft	4,3ft	5,7ft	8,5ft	11,4ft	14,2ft	17,1ft	22,8ft	28,5ft

## LINEAR DISTRIBUTION DIAGRAM

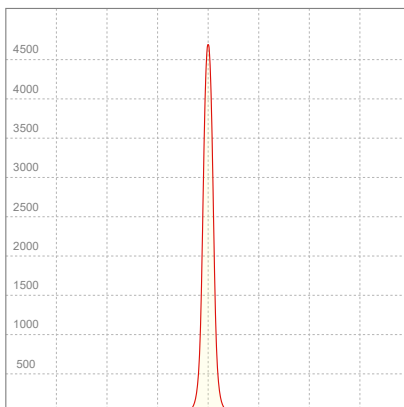

## ELECTRICAL SPECIFICATIONS

Input voltage	Input current	Input power	Effeciency
229V	0,505A	101,3W	2lm/W

Power FC
0,88

## ISO CANDELA DIAGRAM

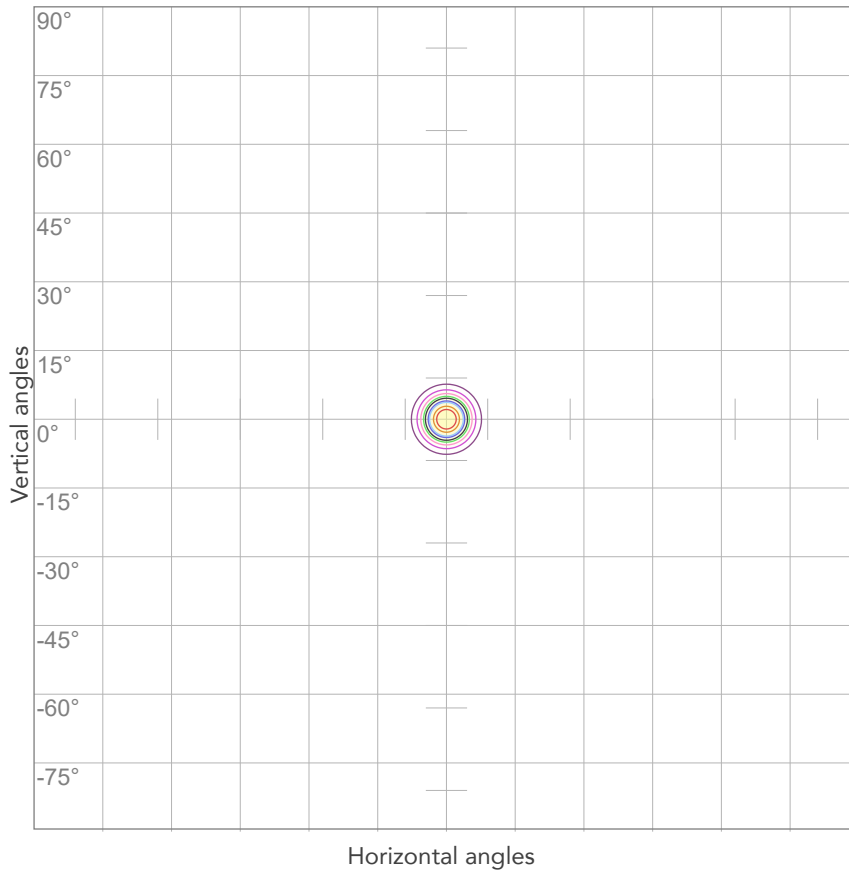

10%	468 cd
20%	937 cd
30%	1405 cd
40%	1873 cd
50%	2341 cd
60%	2810 cd
70%	3278 cd
80%	3746 cd

Conditions:

Number of c-planes: 2

Candela at center: 4683 cd

## ISO LUX DIAGRAM

MH: 10,0 m

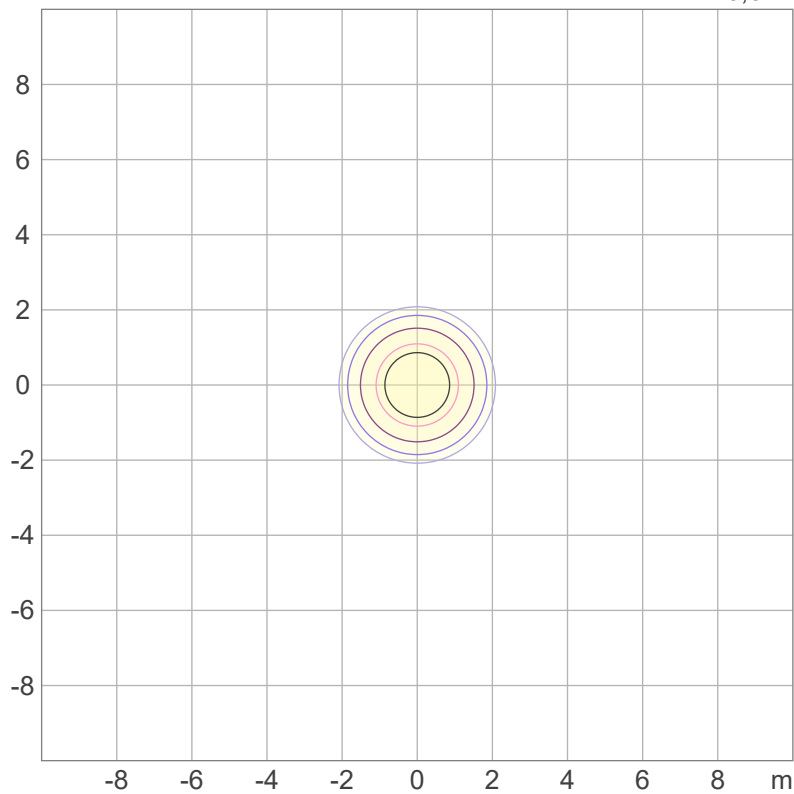

3%	1,40 lx
5%	2,34 lx
10%	4,68 lx
30%	14,0 lx
50%	23,4 lx

Conditions:

Number of c-planes: 2

Lux at center: 46,8 lx

*Lux distribution on a surface when lamp is mounted at 10 meters from the surface.*





Total lumen output:

503 lm

Peak candela output:

617 cd

**PRODUCT NAME:**

**ECLFRCTPLIP**

**MEASURAMENT CONDITIONS:**

Beam angle:

Max Zoom

Target:

Cyan - HB

Operator:

Salvatore Giglio

Date and time:

03/10/2023 13:22:09

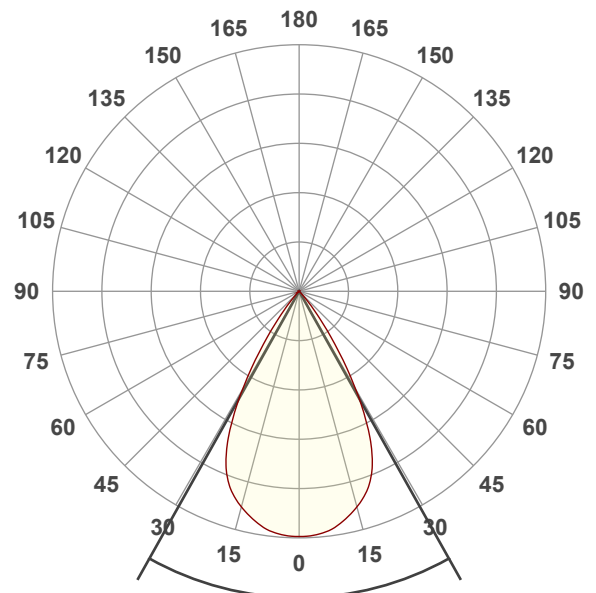

Beam angle 50%: 58,5°

Field angle 10%: 77,3°

Cut off angle 2.5%: 86°

Spectra

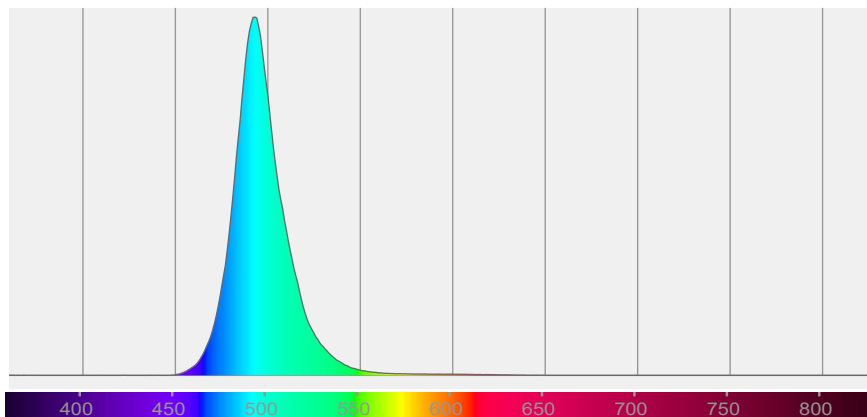

# BEAM DETAILS



Beam angle 50%	Field angle 10%	Cut off angle 2,5%	Intensity ratio in 120° cone	Intensity ratio in 90° cone
58,5°	77,3°	86°	100,0%	99,7%

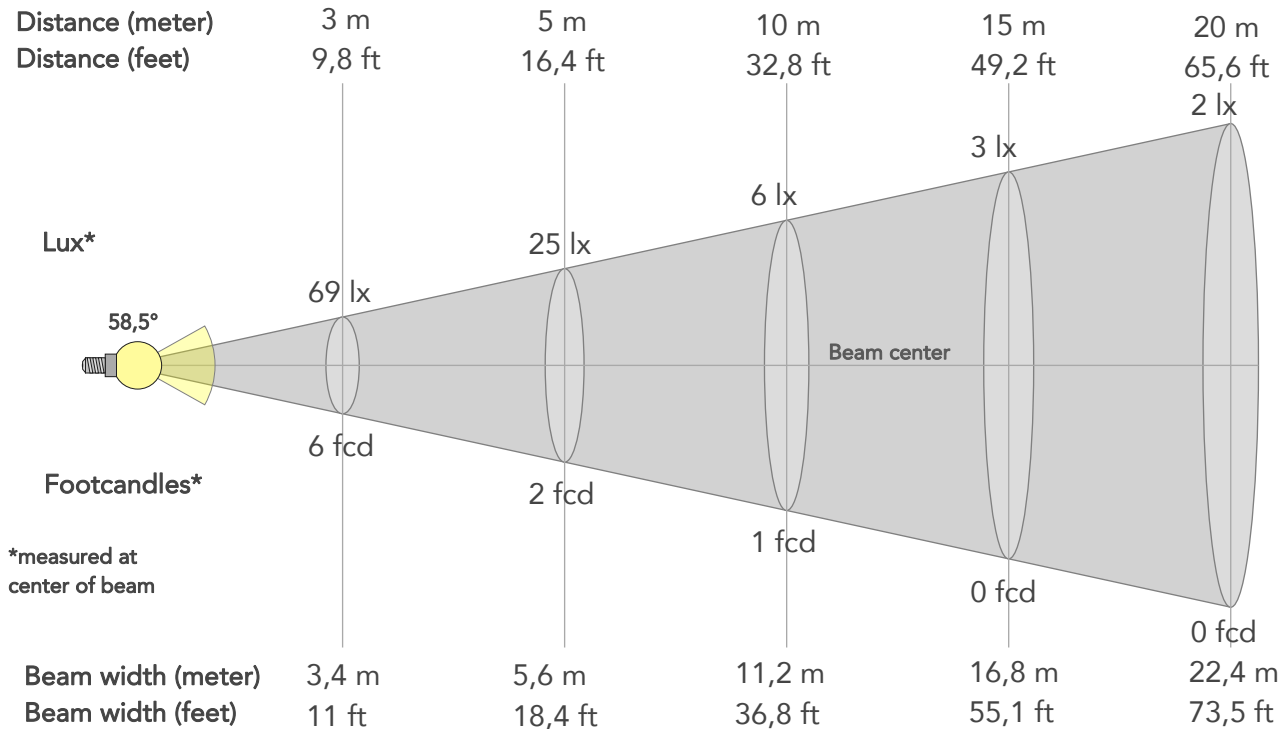

## BEAM INTENSITIES AND WIDTHS

Distance	1m	2m	3m	4m	5m	7,5m	10m	15m	20m	25m	30m	40m	50m
Distance	3,3ft	6,6ft	9,8ft	13,1ft	16,4ft	24,6ft	32,8ft	49,2ft	65,6ft	82ft	98,4ft	131,2ft	164ft
Lux	617lx	154lx	69lx	39lx	25lx	11lx	6lx	3lx	2lx	1lx	1lx	0lx	0lx
Footcand.	57fcd	14fcd	6fcd	4fcd	2fcd	1fcd	1fcd	0fcd	0fcd	0fcd	0fcd	0fcd	0fcd
Beam wid.	1,1m	2,2m	3,4m	4,5m	5,6m	8,4m	11,2m	16,8m	22,4m	28m	33,6m	44,8m	56m
Beam wid.	3,7ft	7,4ft	11ft	14,7ft	18,4ft	27,6ft	36,8ft	55,1ft	73,5ft	91,9ft	110,3ft	147ft	183,8ft

## LINEAR DISTRIBUTION DIAGRAM

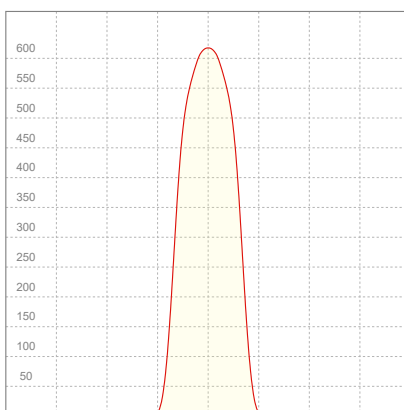

## ELECTRICAL SPECIFICATIONS

Input voltage	Input current	Input power	Effeciency
229V	0,403A	50,7W	10lm/W

Power FC
0,55

## ISO CANDELA DIAGRAM

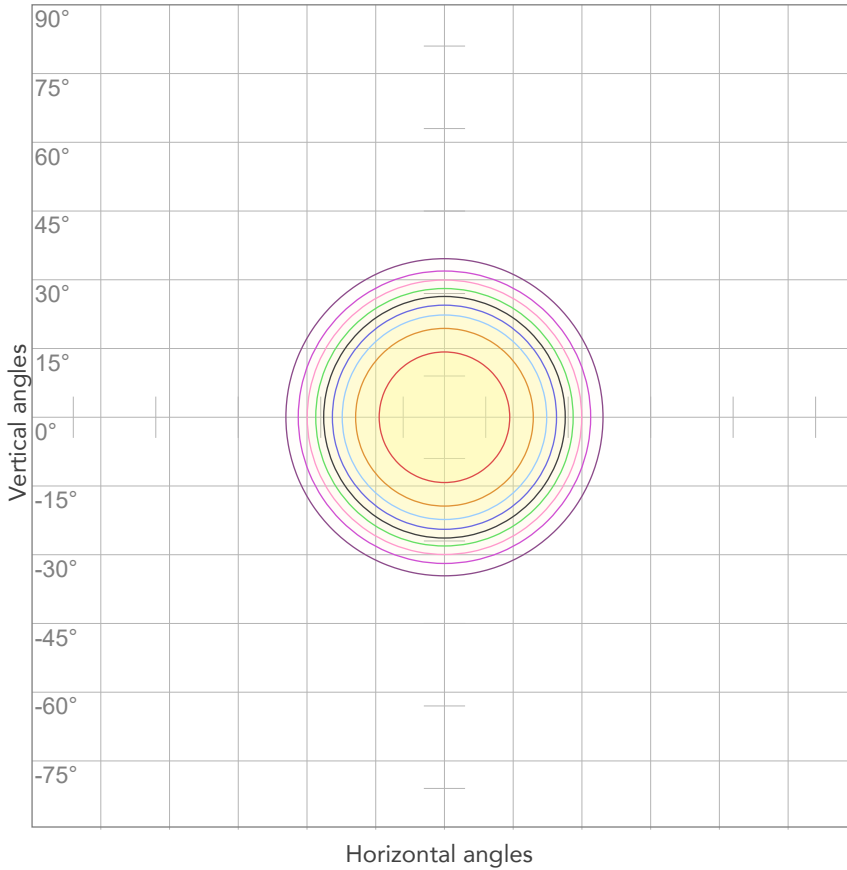

10%	62 cd
20%	123 cd
30%	185 cd
40%	247 cd
50%	308 cd
60%	370 cd
70%	432 cd
80%	494 cd

Conditions:

Number of c-planes: 2

Candela at center: 617 cd

## ISO LUX DIAGRAM

MH: 10,0 m

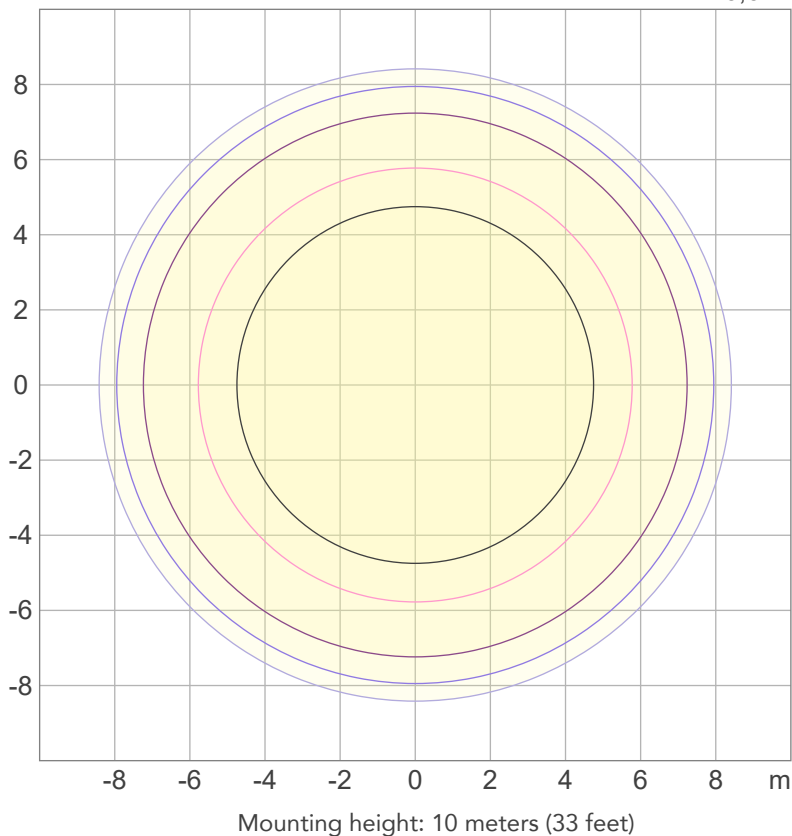

3%	0,185 lx
5%	0,308 lx
10%	0,617 lx
30%	1,85 lx
50%	3,08 lx

Conditions:

Number of c-planes: 2

Lux at center: 6,17 lx

*Lux distribution on a surface when lamp is mounted at 10 meters from the surface.*



Total lumen output:

407 lm

Peak candela output:

2060 cd

**PRODUCT NAME:**

**ECLFRCTPLIP**

**MEASURAMENT CONDITIONS:**

Beam angle:

Med Zoom

Target:

Cyan - HB

Operator:

Salvatore Giglio

Date and time:

03/10/2023 14:50:17

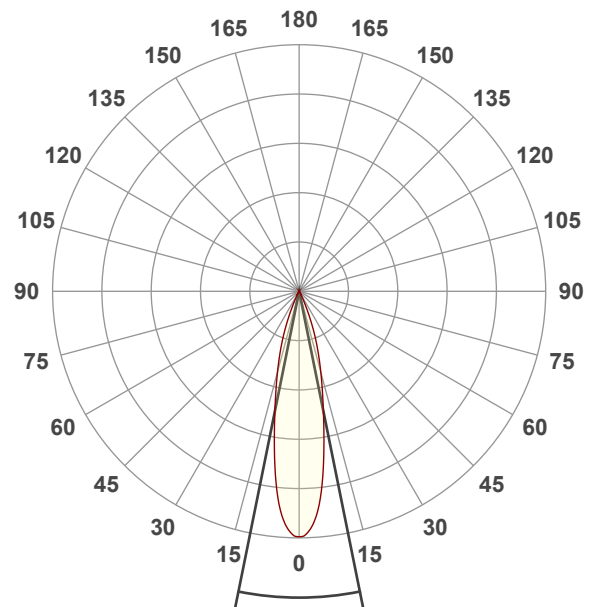

Beam angle 50%: 22,9°

Field angle 10%: 45,2°

Cut off angle 2.5%: 53,7°

Spectra

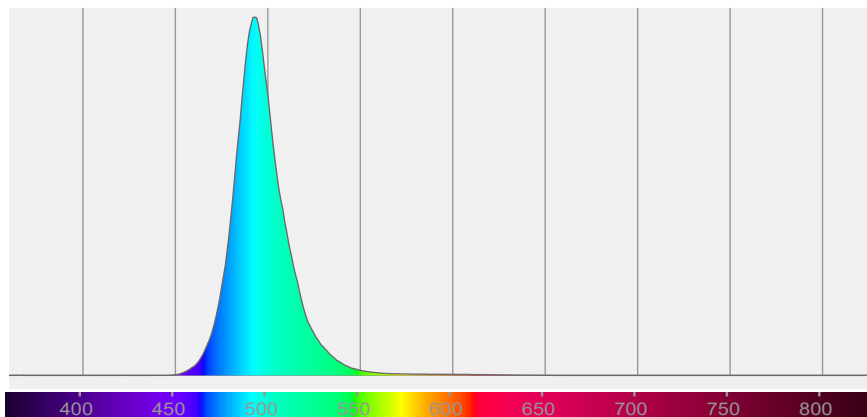

Beam angle 50%	Field angle 10%	Cut off angle 2,5%	Intensity ratio in 120° cone	Intensity ratio in 90° cone
22,9°	45,2°	53,7°	100,0%	99,9%

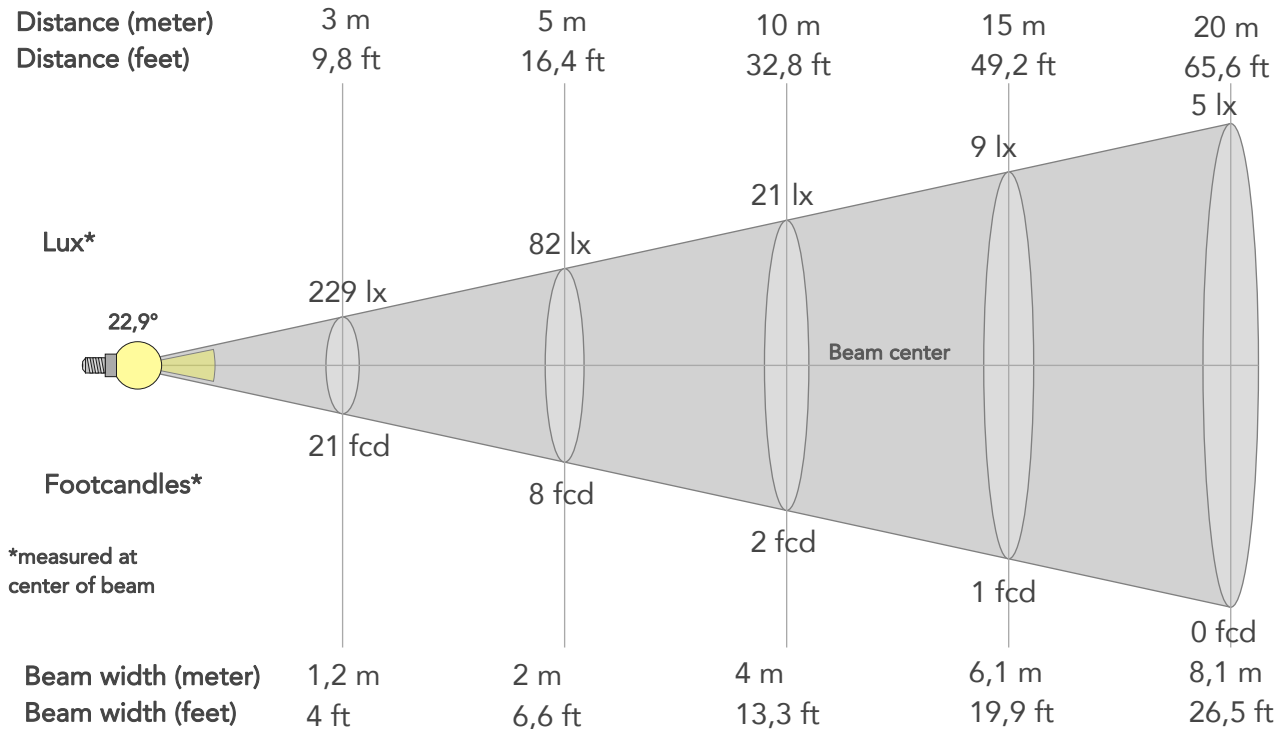

### BEAM INTENSITIES AND WIDTHS

Distance	1m	2m	3m	4m	5m	7,5m	10m	15m	20m	25m	30m	40m	50m
Distance	3,3ft	6,6ft	9,8ft	13,1ft	16,4ft	24,6ft	32,8ft	49,2ft	65,6ft	82ft	98,4ft	131,2ft	164ft
Lux	2060lx	515lx	229lx	129lx	82lx	37lx	21lx	9lx	5lx	3lx	2lx	1lx	1lx
Footcand.	191fcd	48fcd	21fcd	12fcd	8fcd	3fcd	2fcd	1fcd	0fcd	0fcd	0fcd	0fcd	0fcd
Beam wid.	0,4m	0,8m	1,2m	1,6m	2m	3m	4m	6,1m	8,1m	10,1m	12,1m	16,2m	20,2m
Beam wid.	1,3ft	2,7ft	4ft	5,3ft	6,6ft	9,9ft	13,3ft	19,9ft	26,5ft	33,2ft	39,8ft	53,1ft	66,3ft

### LINEAR DISTRIBUTION DIAGRAM

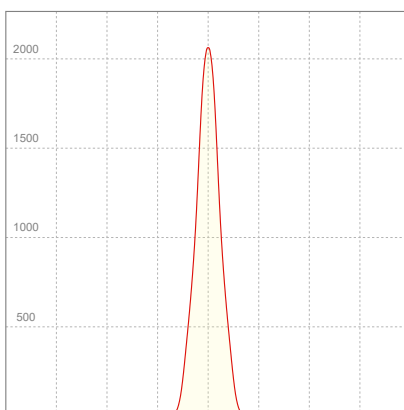

### ELECTRICAL SPECIFICATIONS

Input voltage	Input current	Input power	Effeciency
228V	0,402A	50,3W	8lm/W

Power FC
0,55

## ISO CANDELA DIAGRAM

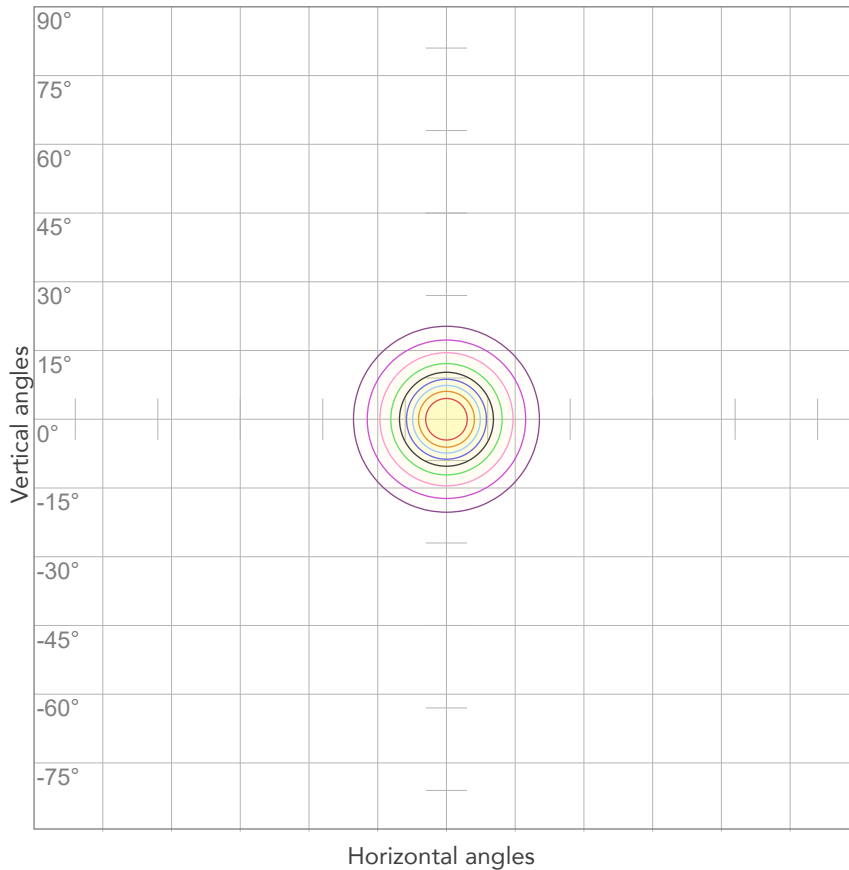

10%	206 cd
20%	412 cd
30%	618 cd
40%	824 cd
50%	1030 cd
60%	1236 cd
70%	1442 cd
80%	1648 cd

Conditions:

Number of c-planes: 2

Candela at center: 2060 cd

## ISO LUX DIAGRAM

MH: 10,0 m

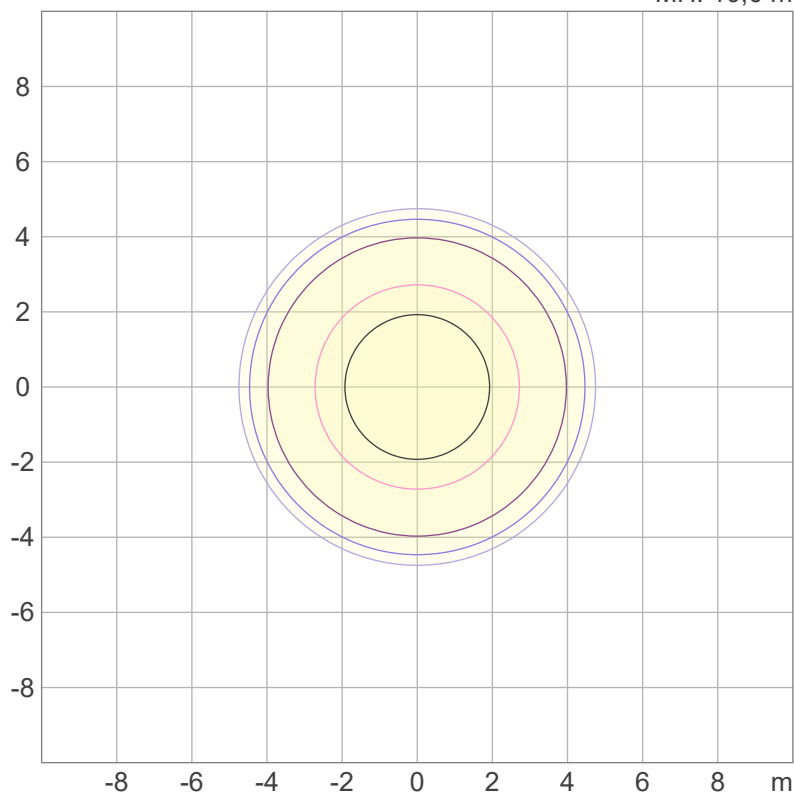

3%	0,618 lx
5%	1,03 lx
10%	2,06 lx
30%	6,18 lx
50%	10,3 lx

Conditions:

Number of c-planes: 2

Lux at center: 20,6 lx

*Lux distribution on a surface when lamp is mounted at 10 meters from the surface.*



Total lumen output:

221 lm

Peak candela output:

5487 cd

**PRODUCT NAME:**  
**ECLFRCTPLIP**

**MEASURAMENT CONDITIONS:**

Beam angle:

Min Zoom

Target:

Cyan - HB

Operator:

Salvatore Giglio

Date and time:

03/10/2023 13:53:09

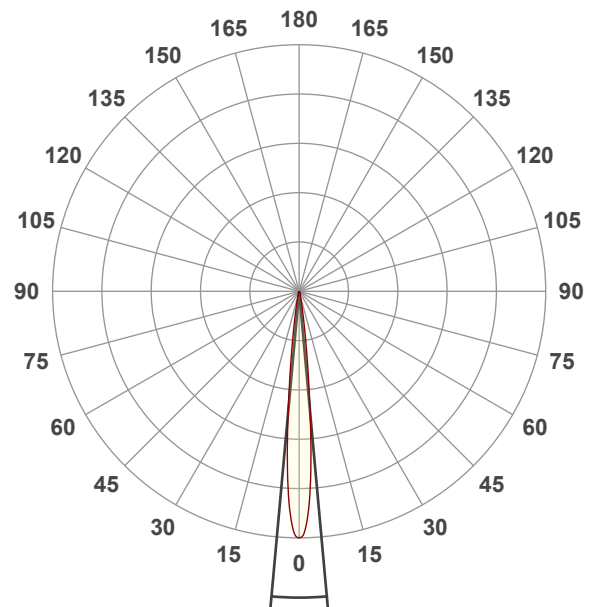

Beam angle 50%: 10,4°

Field angle 10%: 18,8°

Cut off angle 2.5%: 26,2°

Spectra

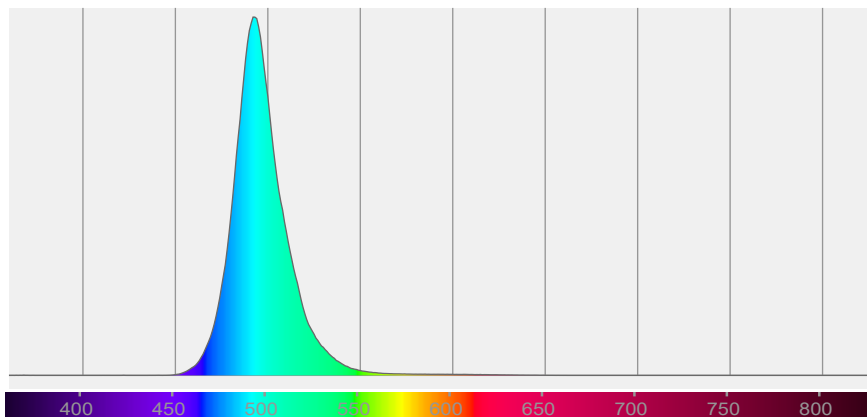

# BEAM DETAILS



Beam angle 50%	Field angle 10%	Cut off angle 2,5%	Intensity ratio in 120° cone	Intensity ratio in 90° cone
10,4°	18,8°	26,2°	100,0%	100,0%

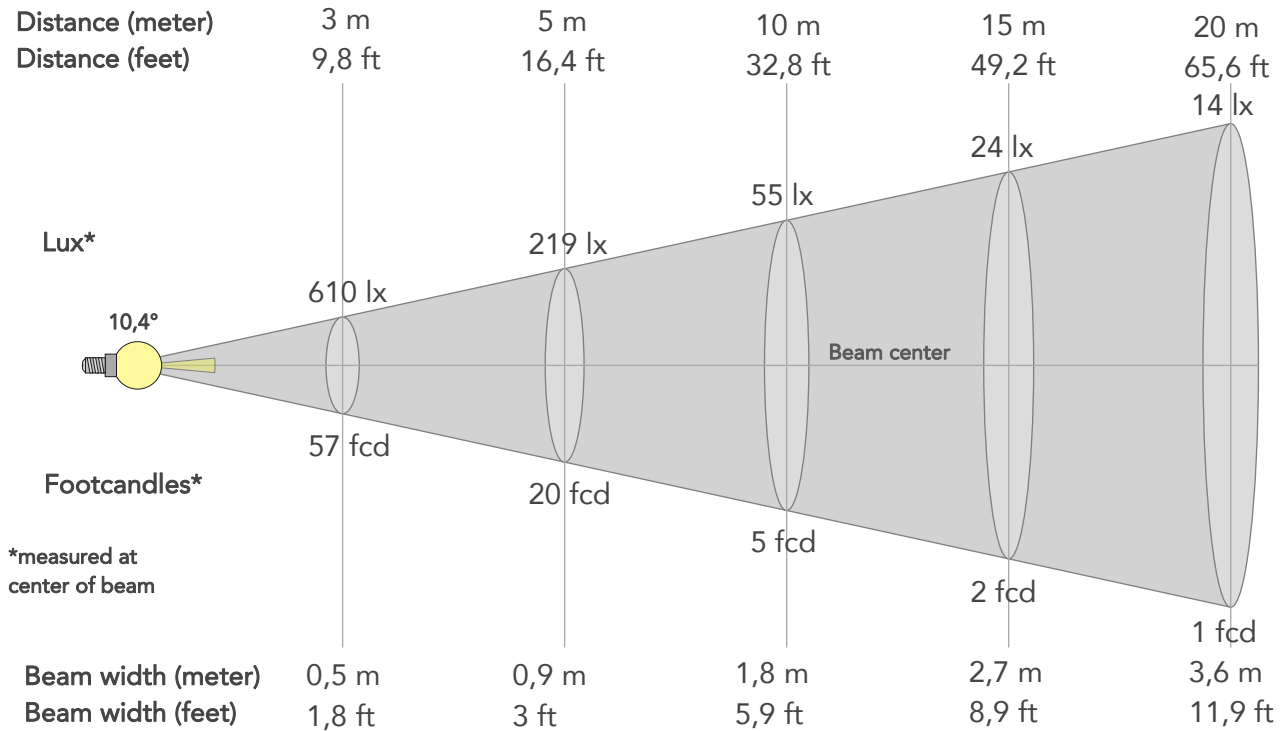

## BEAM INTENSITIES AND WIDTHS

Distance	1m	2m	3m	4m	5m	7,5m	10m	15m	20m	25m	30m	40m	50m
Distance	3,3ft	6,6ft	9,8ft	13,1ft	16,4ft	24,6ft	32,8ft	49,2ft	65,6ft	82ft	98,4ft	131,2ft	164ft
Lux	5487lx	1372lx	610lx	343lx	219lx	98lx	55lx	24lx	14lx	9lx	6lx	3lx	2lx
Footcand.	510fcd	127fcd	57fcd	32fcd	20fcd	9fcd	5fcd	2fcd	1fcd	1fcd	1fcd	0fcd	0fcd
Beam wid.	0,2m	0,4m	0,5m	0,7m	0,9m	1,4m	1,8m	2,7m	3,6m	4,5m	5,4m	7,3m	9,1m
Beam wid.	0,6ft	1,2ft	1,8ft	2,4ft	3ft	4,5ft	5,9ft	8,9ft	11,9ft	14,9ft	17,8ft	23,8ft	29,7ft

## LINEAR DISTRIBUTION DIAGRAM

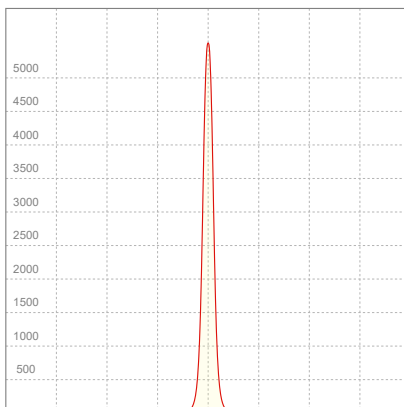

## ELECTRICAL SPECIFICATIONS

Input voltage	Input current	Input power	Effeciency
229V	0,402A	50,8W	4lm/W

Power FC
0,55



## ISO CANDELA DIAGRAM

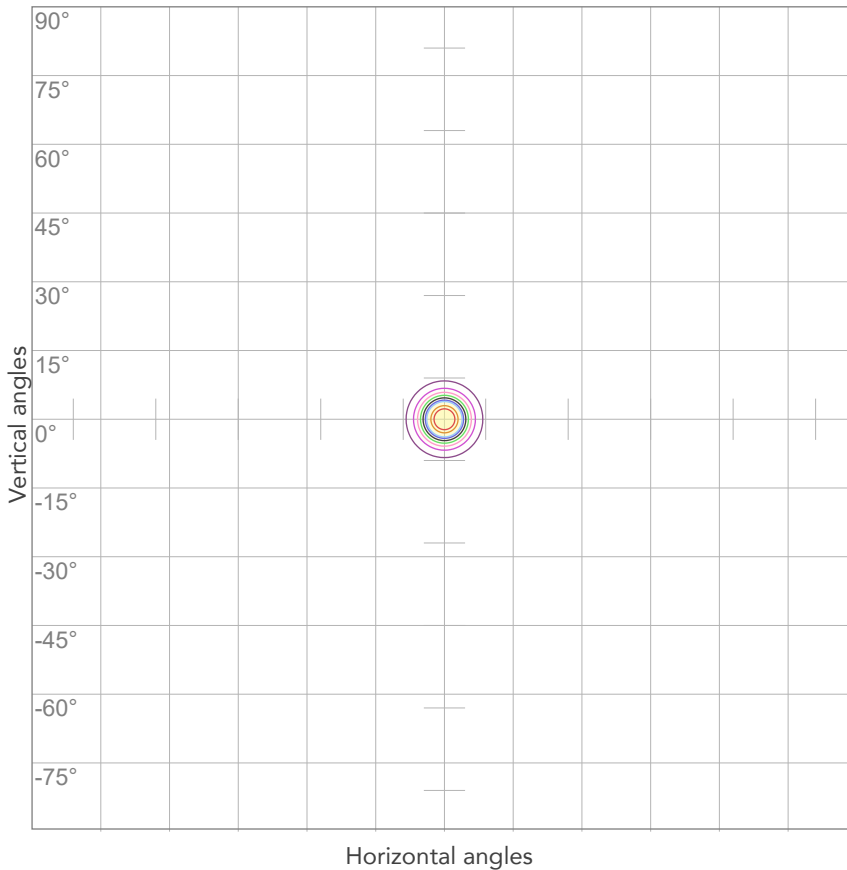

10%	549 cd
20%	1097 cd
30%	1646 cd
40%	2195 cd
50%	2744 cd
60%	3292 cd
70%	3841 cd
80%	4390 cd

Conditions:

Number of c-planes: 2

Candela at center: 5487 cd

## ISO LUX DIAGRAM

MH: 10,0 m

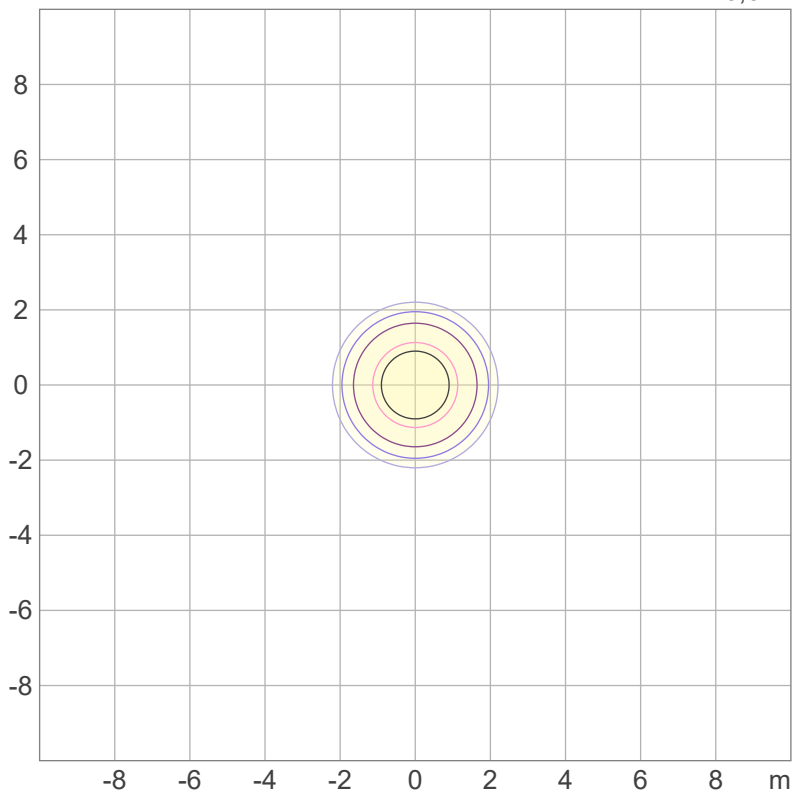

3%	1,65 lx
5%	2,74 lx
10%	5,49 lx
30%	16,5 lx
50%	27,4 lx

Conditions:

Number of c-planes: 2

Lux at center: 54,9 lx

*Lux distribution on a surface when lamp is mounted at 10 meters from the surface.*



Total lumen output:

8225 lm

Peak candela output:

10867 cd

**PRODUCT NAME:**  
**ECLFRCTPLIP**

**MEASURAMENT CONDITIONS:**

Beam angle:

Max Zoom

Target:

Mint - HB

Operator:

Salvatore Giglio

Date and time:

03/10/2023 13:27:08

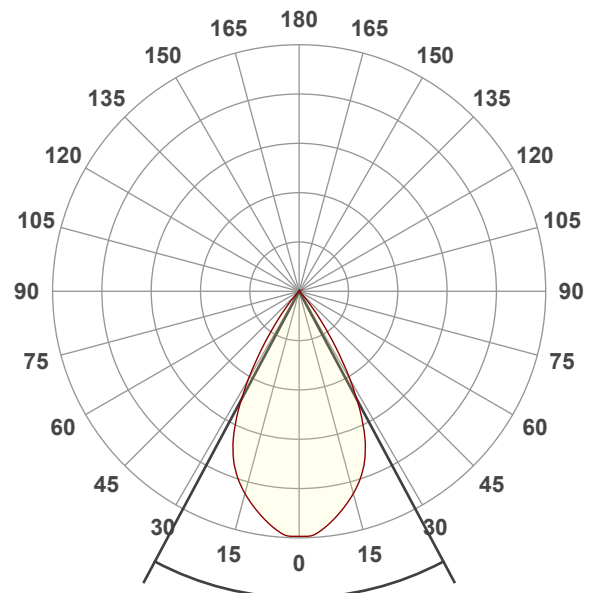

Beam angle 50%: 56,2°

Field angle 10%: 76,9°

Cut off angle 2.5%: 86,5°

Spectra

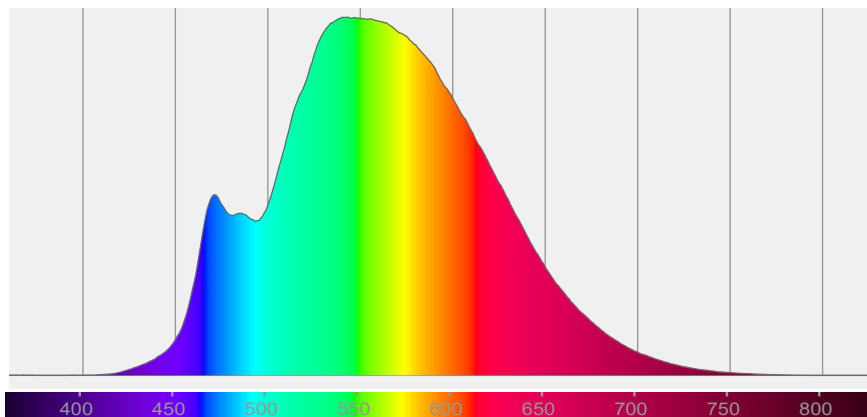

# BEAM DETAILS



Beam angle 50%	Field angle 10%	Cut off angle 2,5%	Intensity ratio in 120° cone	Intensity ratio in 90° cone
56,2°	76,9°	86,5°	100,0%	99,4%

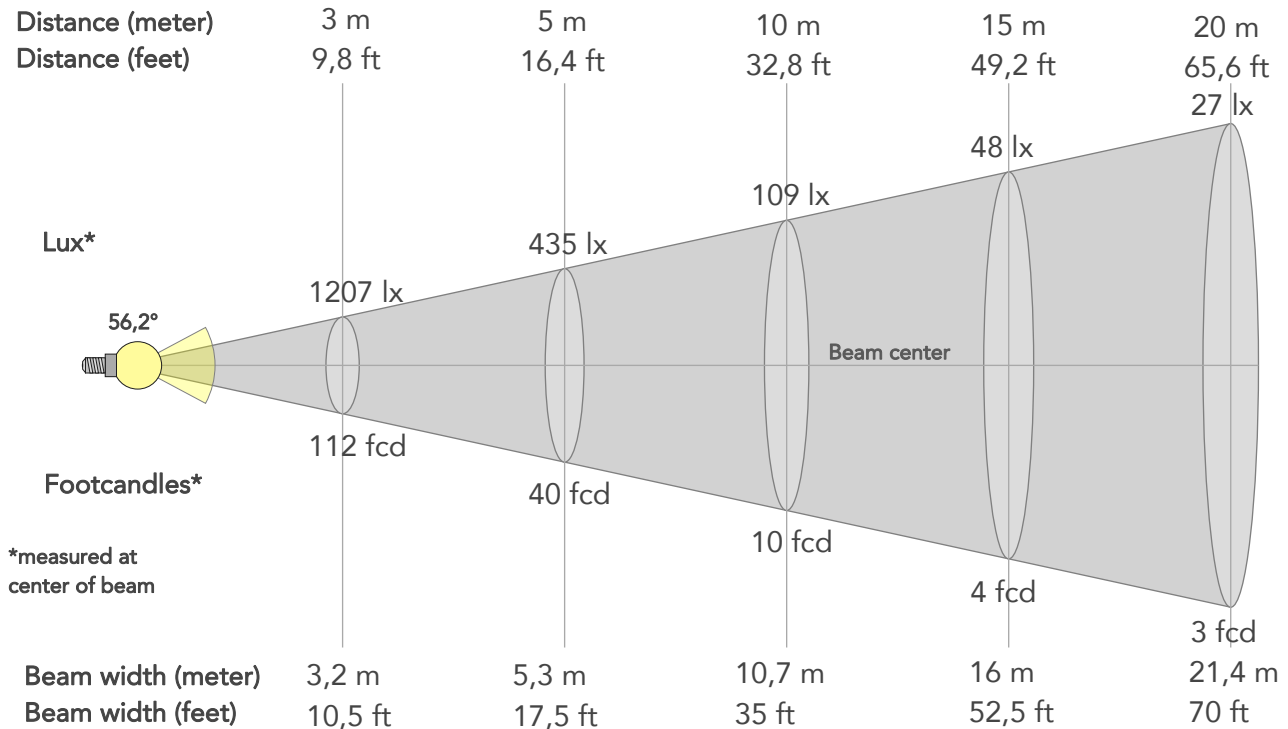

## BEAM INTENSITIES AND WIDTHS

Distance	1m	2m	3m	4m	5m	7,5m	10m	15m	20m	25m	30m	40m	50m
Distance	3,3ft	6,6ft	9,8ft	13,1ft	16,4ft	24,6ft	32,8ft	49,2ft	65,6ft	82ft	98,4ft	131,2ft	164ft
Lux	10867lx	2717lx	1207lx	679lx	435lx	193lx	109lx	48lx	27lx	17lx	12lx	7lx	4lx
Footcand.	1010fcd	252fcd	112fcd	63fcd	40fcd	18fcd	10fcd	4fcd	3fcd	2fcd	1fcd	1fcd	0fcd
Beam wid.	1,1m	2,1m	3,2m	4,3m	5,3m	8m	10,7m	16m	21,4m	26,7m	32m	42,7m	53,4m
Beam wid.	3,5ft	7ft	10,5ft	14ft	17,5ft	26,3ft	35ft	52,5ft	70ft	87,6ft	105,1ft	140,1ft	175,1ft

## LINEAR DISTRIBUTION DIAGRAM

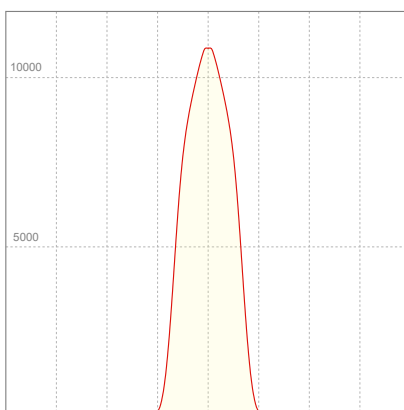

## ELECTRICAL SPECIFICATIONS

Input voltage	Input current	Input power	Effeciency
228V	0,936A	207,7W	40lm/W

Power FC
0,97

## ISO CANDELA DIAGRAM

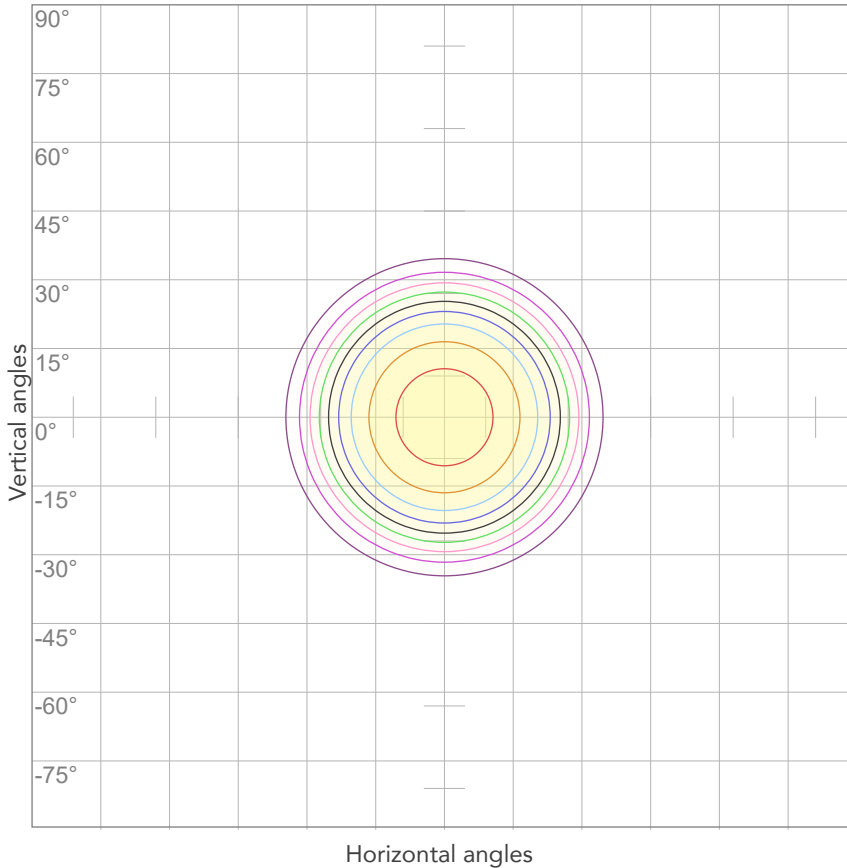

10%	1087 cd
20%	2173 cd
30%	3260 cd
40%	4347 cd
50%	5434 cd
60%	6520 cd
70%	7607 cd
80%	8694 cd

Conditions:

Number of c-planes: 2

Candela at center: 10867 cd

## ISO LUX DIAGRAM

MH: 10,0 m

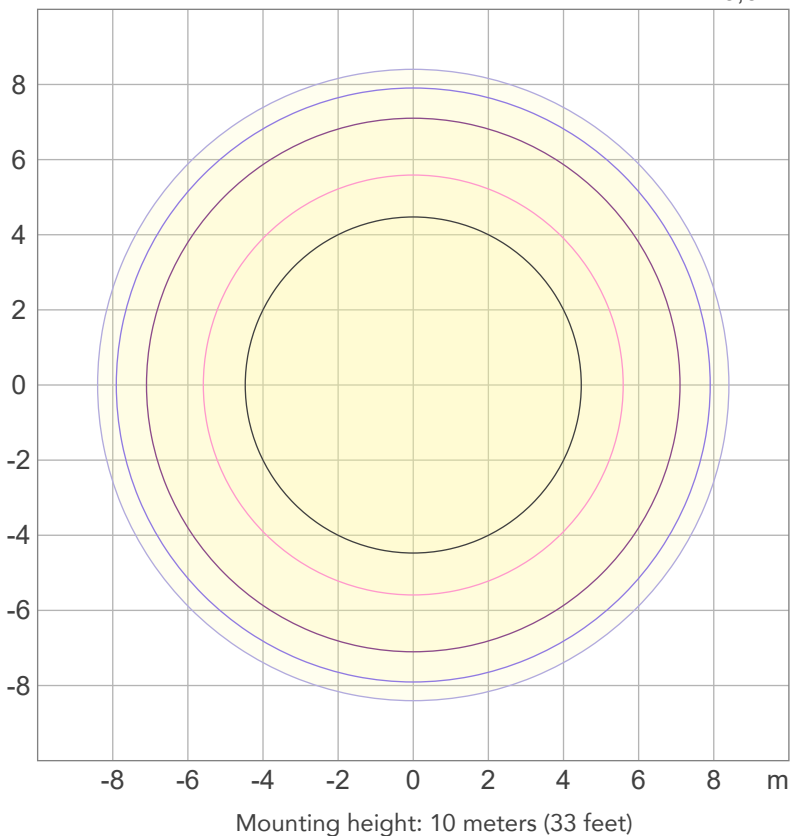

3%	3,26 lx
5%	5,43 lx
10%	10,9 lx
30%	32,6 lx
50%	54,3 lx

Conditions:

Number of c-planes: 2

Lux at center: 109 lx

*Lux distribution on a surface when lamp is mounted at 10 meters from the surface.*



Total lumen output:

6711 lm

Peak candela output:

35383 cd

**PRODUCT NAME:**  
**ECLFRCTPLIP**

**MEASUREMENT CONDITIONS:**

Beam angle:  
Med Zoom

Target:  
Mint - HB

Operator:  
Salvatore Giglio

Date and time:  
03/10/2023 14:51:38

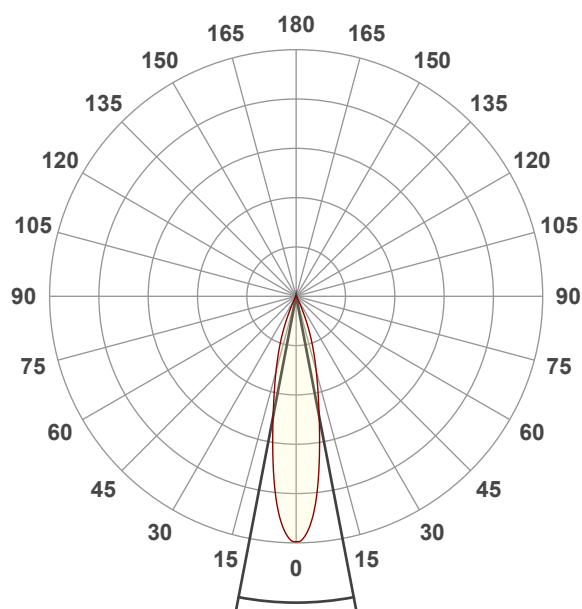

Beam angle 50%: 21,7°  
Field angle 10%: 45°  
Cut off angle 2.5%: 54,2°

Spectra

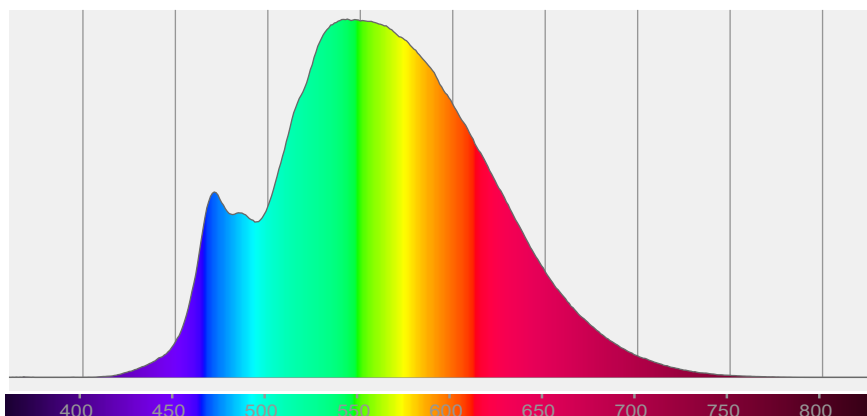

# BEAM DETAILS



Beam angle 50%	Field angle 10%	Cut off angle 2,5%	Intensity ratio in 120° cone	Intensity ratio in 90° cone
21,7°	45°	54,2°	100,0%	99,9%

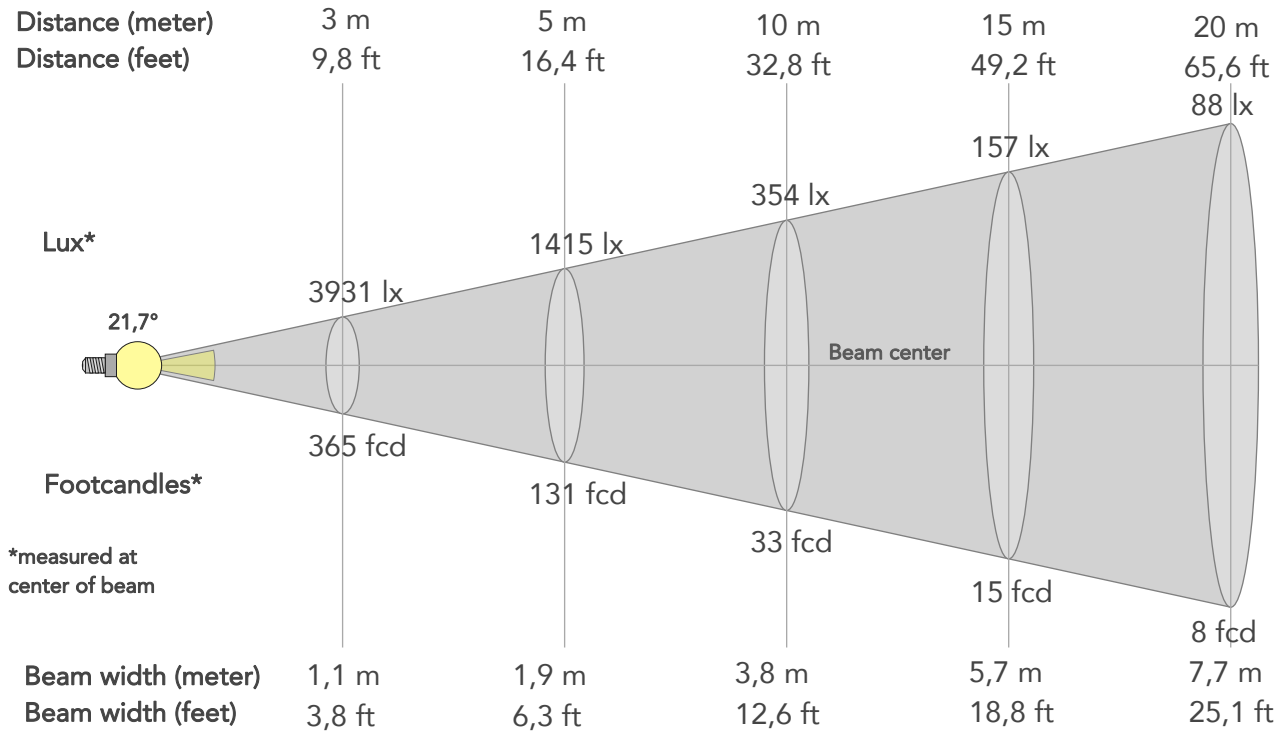

## BEAM INTENSITIES AND WIDTHS

Distance	1m	2m	3m	4m	5m	7,5m	10m	15m	20m	25m	30m	40m	50m
Distance	3,3ft	6,6ft	9,8ft	13,1ft	16,4ft	24,6ft	32,8ft	49,2ft	65,6ft	82ft	98,4ft	131,2ft	164ft
Lux	35383lx	8846lx	3931lx	2211lx	1415lx	629lx	354lx	157lx	88lx	57lx	39lx	22lx	14lx
Footcand.	3287fcd	822fcd	365fcd	205fcd	131fcd	58fcd	33fcd	15fcd	8fcd	5fcd	4fcd	2fcd	1fcd
Beam wid.	0,4m	0,8m	1,1m	1,5m	1,9m	2,9m	3,8m	5,7m	7,7m	9,6m	11,5m	15,3m	19,1m
Beam wid.	1,3ft	2,5ft	3,8ft	5ft	6,3ft	9,4ft	12,6ft	18,8ft	25,1ft	31,4ft	37,7ft	50,2ft	62,8ft

## LINEAR DISTRIBUTION DIAGRAM

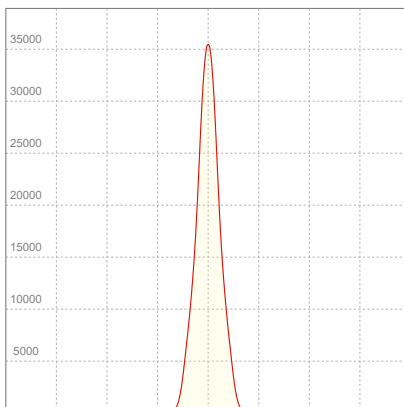

## ELECTRICAL SPECIFICATIONS

Input voltage	Input current	Input power	Effeciency
227V	0,940A	207,3W	32lm/W

Power FC
0,97

## ISO CANDELA DIAGRAM

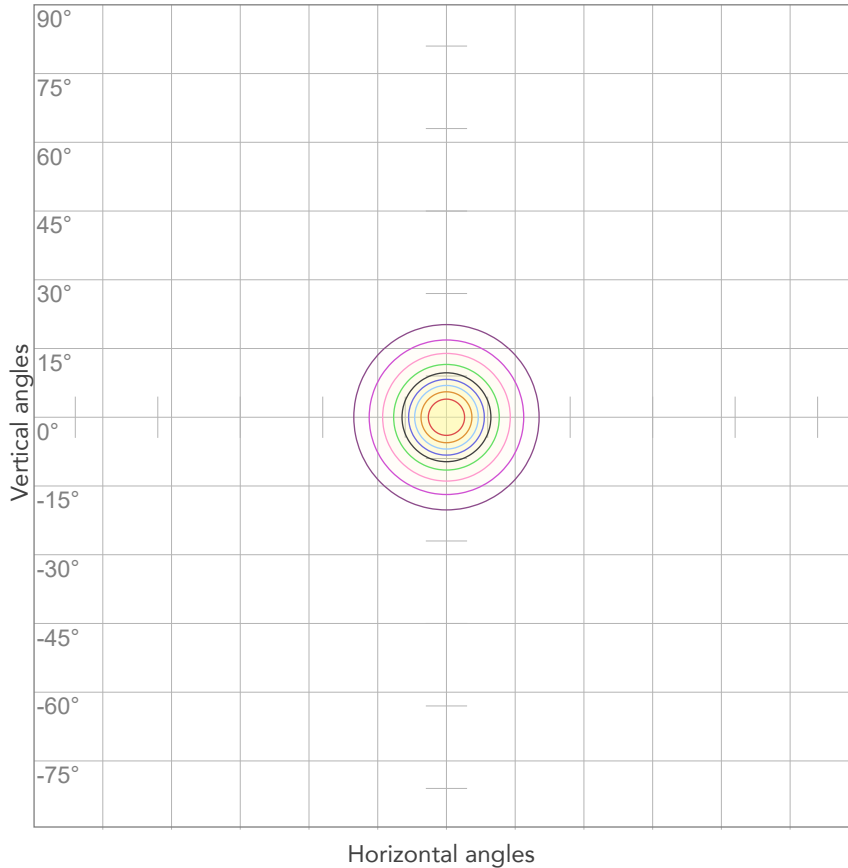

10%	3538 cd
20%	7077 cd
30%	10615 cd
40%	14153 cd
50%	17691 cd
60%	21230 cd
70%	24768 cd
80%	28306 cd

Conditions:

Number of c-planes: 2

Candela at center: 35383 cd

## ISO LUX DIAGRAM

MH: 10,0 m

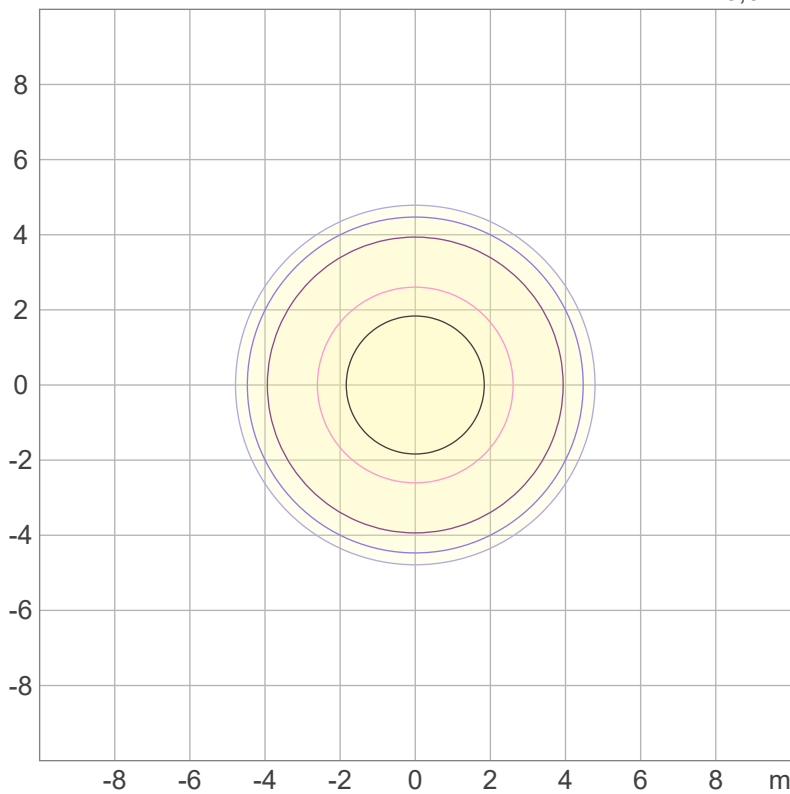

Mounting height: 10 meters (33 feet)

3%	10,6 lx
5%	17,7 lx
10%	35,4 lx
30%	106 lx
50%	177 lx

Conditions:

Number of c-planes: 2

Lux at center: 354 lx

*Lux distribution on a surface when lamp is mounted at 10 meters from the surface.*



Total lumen output:

3671 lm

Peak candela output:

93106 cd

PRODUCT NAME:

ECLFRCTPLIP

MEASUREMENT CONDITIONS:

Beam angle:

Min Zoom

Target:

Mint - HB

Operator:

Salvatore Giglio

Date and time:

03/10/2023 13:54:46

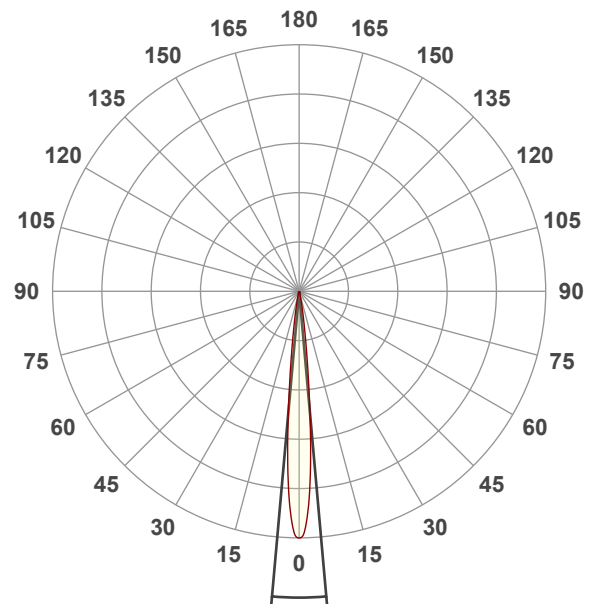

Beam angle 50%: 10,2°

Field angle 10%: 18,9°

Cut off angle 2.5%: 26,6°

Spectra

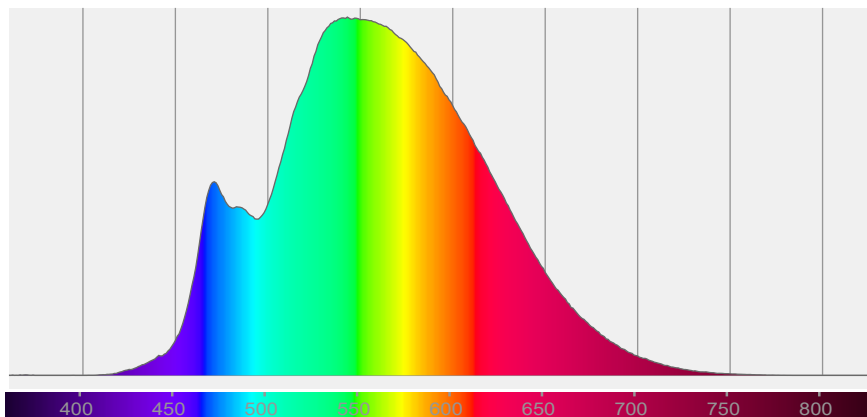



# BEAM DETAILS



Beam angle 50%	Field angle 10%	Cut off angle 2,5%	Intensity ratio in 120° cone	Intensity ratio in 90° cone
10,2°	18,9°	26,6°	100,0%	100,0%

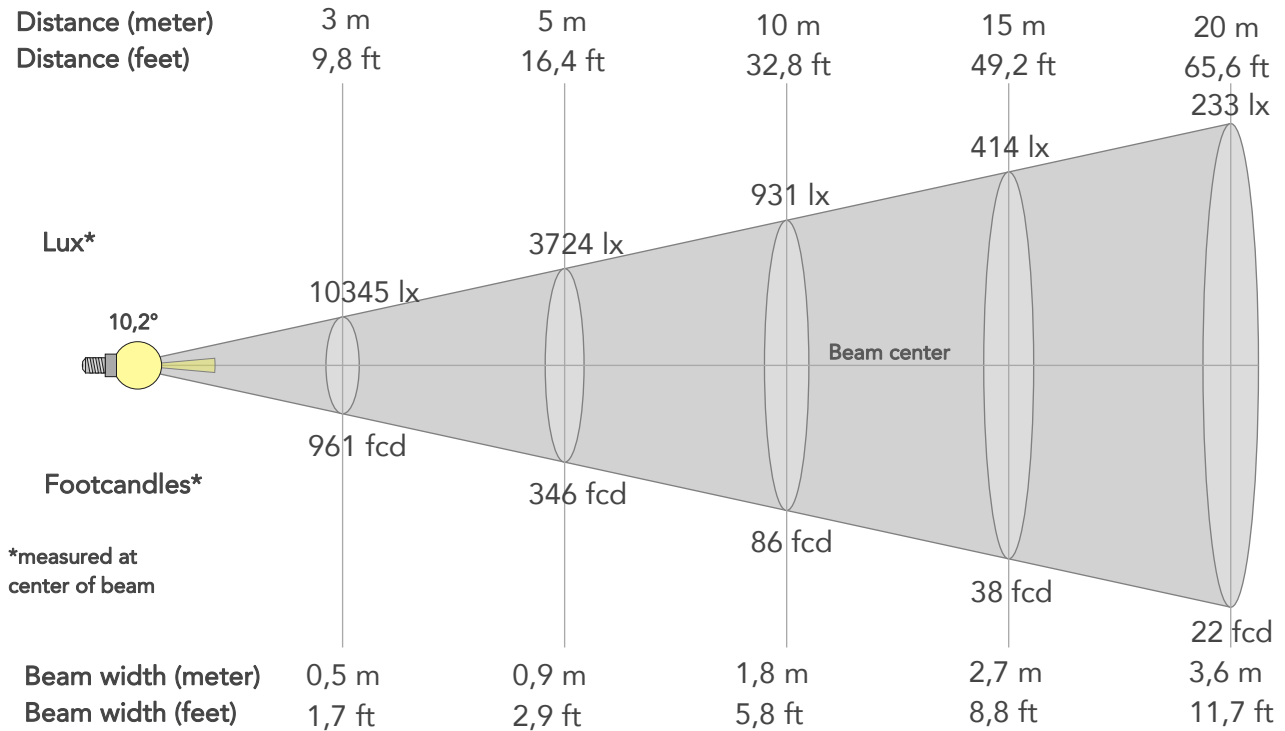

## BEAM INTENSITIES AND WIDTHS

Distance	1m	2m	3m	4m	5m	7,5m	10m	15m	20m	25m	30m	40m	50m
Distance	3,3ft	6,6ft	9,8ft	13,1ft	16,4ft	24,6ft	32,8ft	49,2ft	65,6ft	82ft	98,4ft	131,2ft	164ft
Lux	93105lx	23276lx	10345lx	5819lx	3724lx	1655lx	931lx	414lx	233lx	149lx	103lx	58lx	37lx
Footcand.	8650fcd	2162fcd	961fcd	541fcd	346fcd	154fcd	86fcd	38fcd	22fcd	14fcd	10fcd	5fcd	3fcd
Beam wid.	0,2m	0,4m	0,5m	0,7m	0,9m	1,3m	1,8m	2,7m	3,6m	4,4m	5,3m	7,1m	8,9m
Beam wid.	0,6ft	1,2ft	1,7ft	2,3ft	2,9ft	4,4ft	5,8ft	8,8ft	11,7ft	14,6ft	17,5ft	23,3ft	29,2ft

## LINEAR DISTRIBUTION DIAGRAM

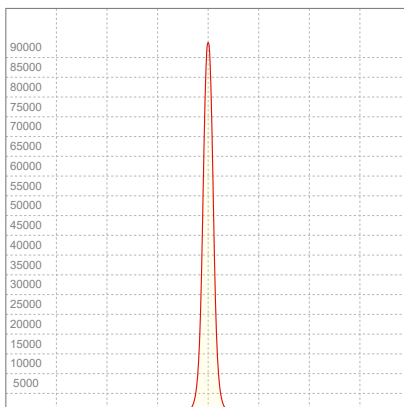

## ELECTRICAL SPECIFICATIONS

Input voltage	Input current	Input power	Effeciency
228V	0,936A	207,7W	18lm/W

Power FC
0,97

## ISO CANDELA DIAGRAM

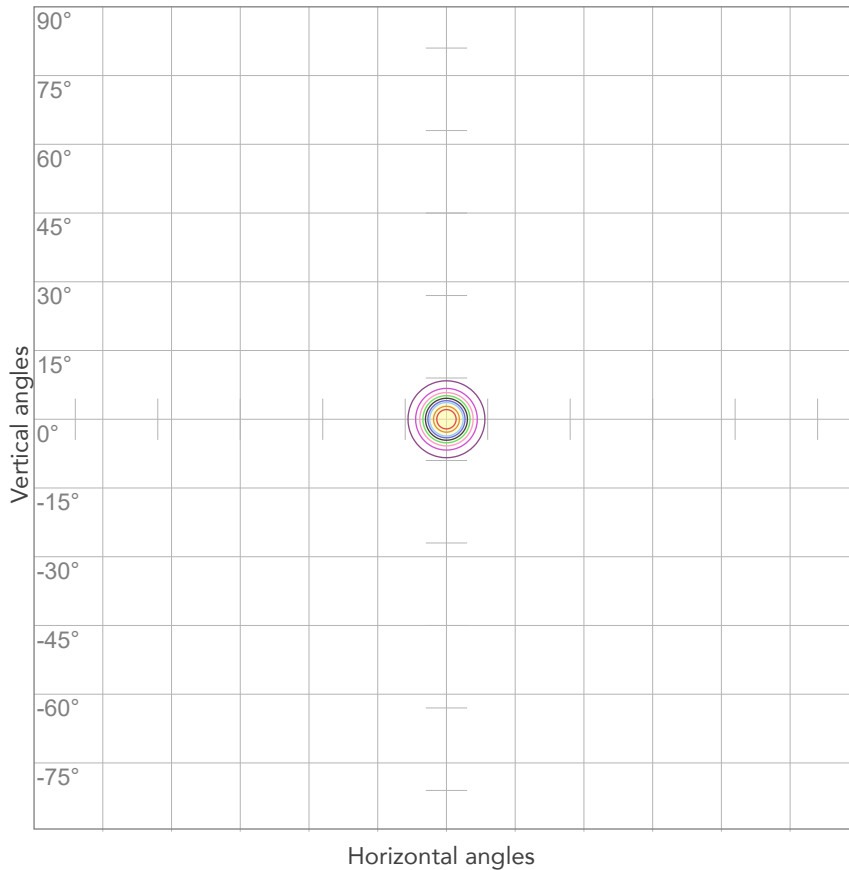

10%	9311 cd
20%	18621 cd
30%	27932 cd
40%	37242 cd
50%	46553 cd
60%	55863 cd
70%	65174 cd
80%	74484 cd

Conditions:

Number of c-planes: 2

Candela at center: 93105 cd

## ISO LUX DIAGRAM

MH: 10,0 m

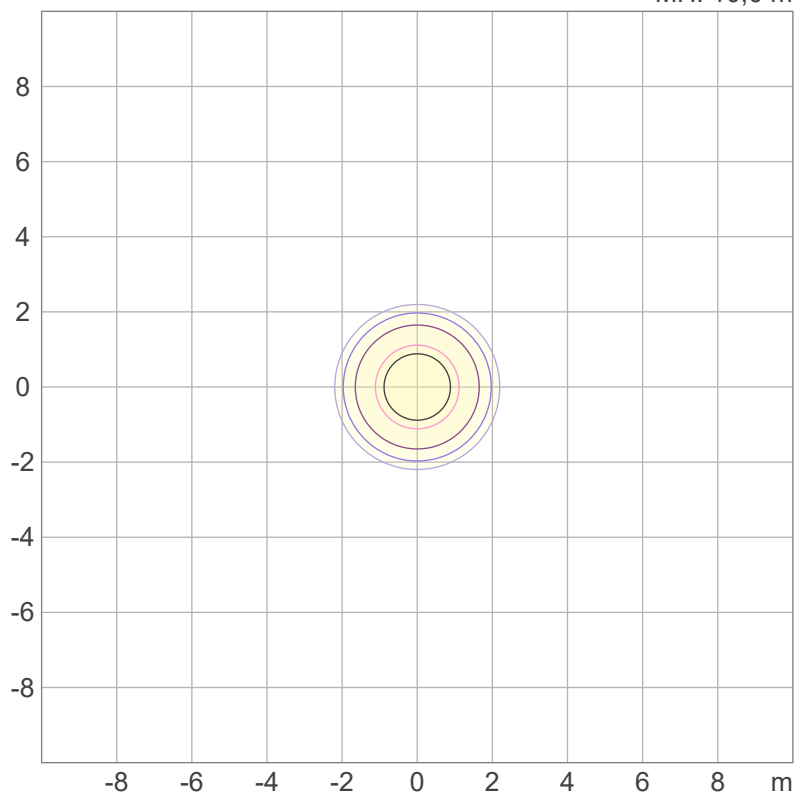

3%	27,9 lx
5%	46,6 lx
10%	93,1 lx
30%	279 lx
50%	466 lx

Conditions:

Number of c-planes: 2

Lux at center: 931 lx

*Lux distribution on a surface when lamp is mounted at 10 meters from the surface.*



Total lumen output:

3269 lm

Peak candela output:

4451 cd

**PRODUCT NAME:**

**ECLFRCTPLIP**

**MEASURAMENT CONDITIONS:**

Beam angle:

Max Zoom

Target:

Amber - HB

Operator:

Salvatore Giglio

Date and time:

03/10/2023 13:29:32

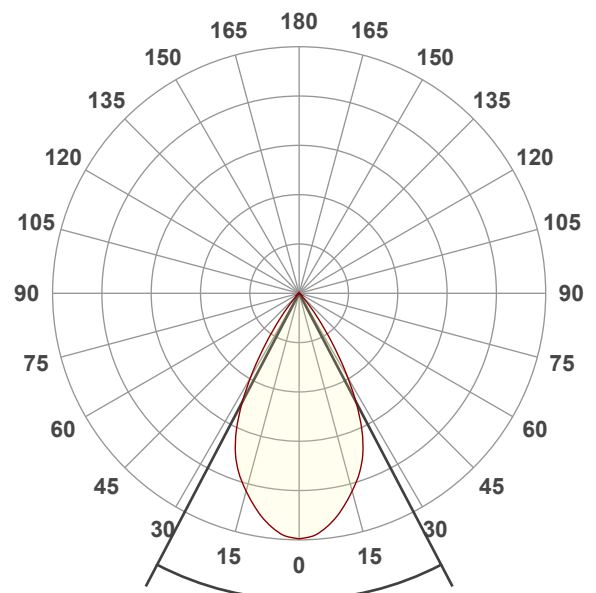

Beam angle 50%: 55,2°

Field angle 10%: 76,6°

Cut off angle 2.5%: 85,8°

Spectra

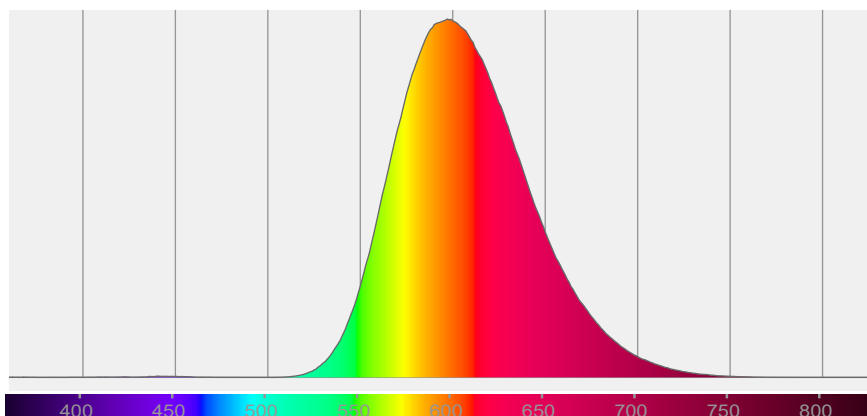

# BEAM DETAILS



Beam angle 50%	Field angle 10%	Cut off angle 2,5%	Intensity ratio in 120° cone	Intensity ratio in 90° cone
55,2°	76,6°	85,8°	100,0%	99,4%

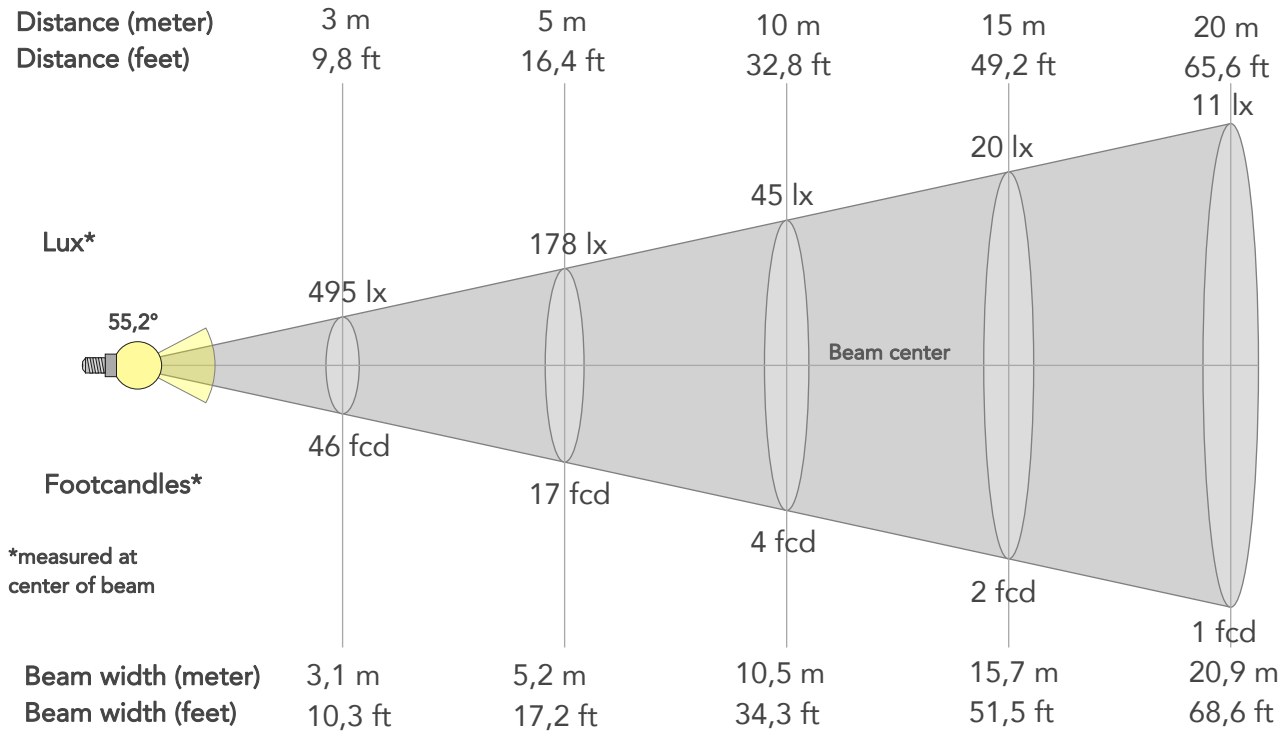

## BEAM INTENSITIES AND WIDTHS

Distance	1m	2m	3m	4m	5m	7,5m	10m	15m	20m	25m	30m	40m	50m
Distance	3,3ft	6,6ft	9,8ft	13,1ft	16,4ft	24,6ft	32,8ft	49,2ft	65,6ft	82ft	98,4ft	131,2ft	164ft
Lux	4451lx	1113lx	495lx	278lx	178lx	79lx	45lx	20lx	11lx	7lx	5lx	3lx	2lx
Footcand.	414fcd	103fcd	46fcd	26fcd	17fcd	7fcd	4fcd	2fcd	1fcd	1fcd	0fcd	0fcd	0fcd
Beam wid.	1m	2,1m	3,1m	4,2m	5,2m	7,8m	10,5m	15,7m	20,9m	26,2m	31,4m	41,9m	52,3m
Beam wid.	3,5ft	6,9ft	10,3ft	13,7ft	17,2ft	25,7ft	34,3ft	51,5ft	68,6ft	85,8ft	103ft	137,3ft	171,6ft

## LINEAR DISTRIBUTION DIAGRAM

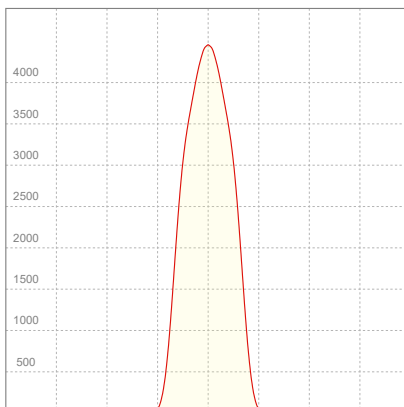

## ELECTRICAL SPECIFICATIONS

Input voltage	Input current	Input power	Effeciency
229V	0,738A	158,9W	21lm/W

Power FC
0,94

## ISO CANDELA DIAGRAM

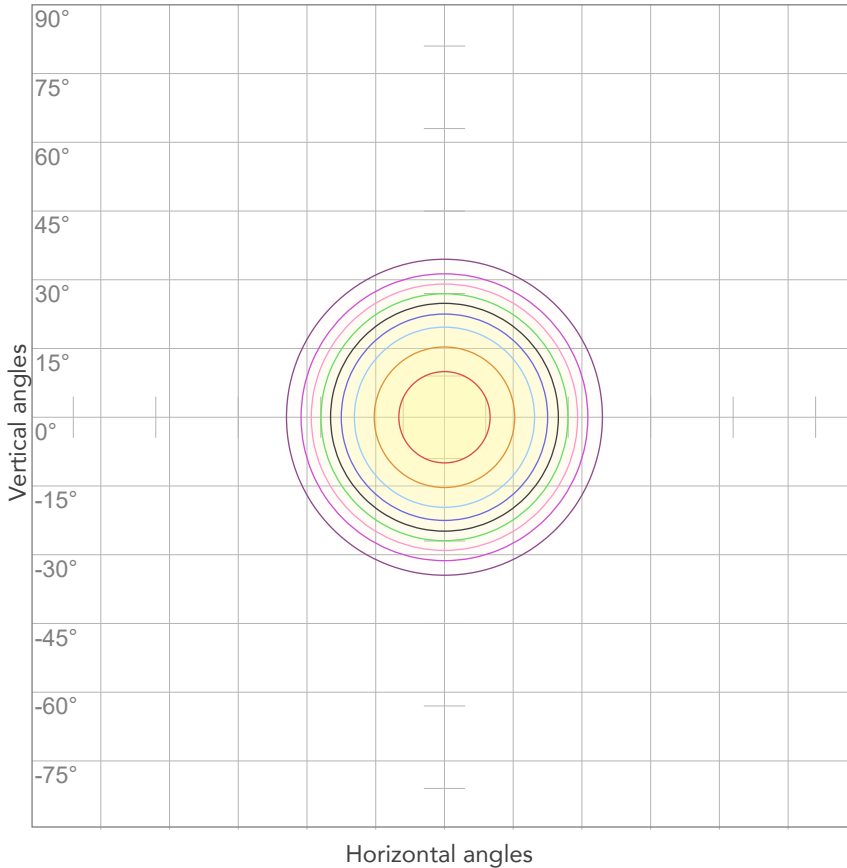

10%	445 cd
20%	890 cd
30%	1335 cd
40%	1781 cd
50%	2226 cd
60%	2671 cd
70%	3116 cd
80%	3561 cd

Conditions:

Number of c-planes: 2

Candela at center: 4451 cd

## ISO LUX DIAGRAM

MH: 10,0 m

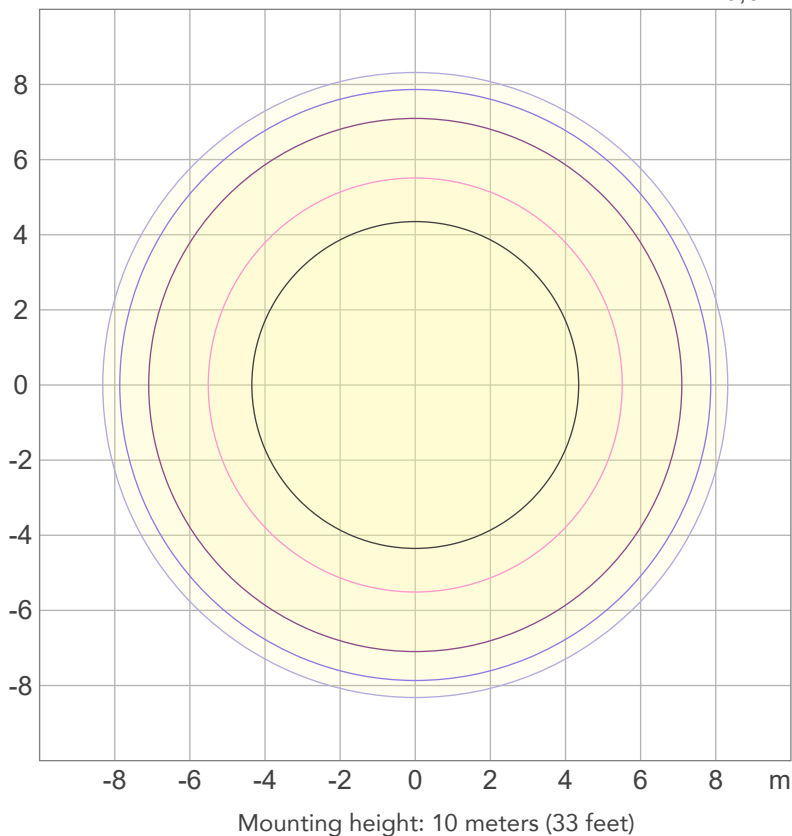

3%	1,34 lx
5%	2,23 lx
10%	4,45 lx
30%	13,4 lx
50%	22,3 lx

Conditions:

Number of c-planes: 2

Lux at center: 44,5 lx

*Lux distribution on a surface when lamp is mounted at 10 meters from the surface.*



Total lumen output:

2667 lm

Peak candela output:

14358 cd

**PRODUCT NAME:**

**ECLFRCTPLIP**

**MEASURAMENT CONDITIONS:**

Beam angle:

Med Zoom

Target:

Amber - HB

Operator:

Salvatore Giglio

Date and time:

03/10/2023 14:53:04

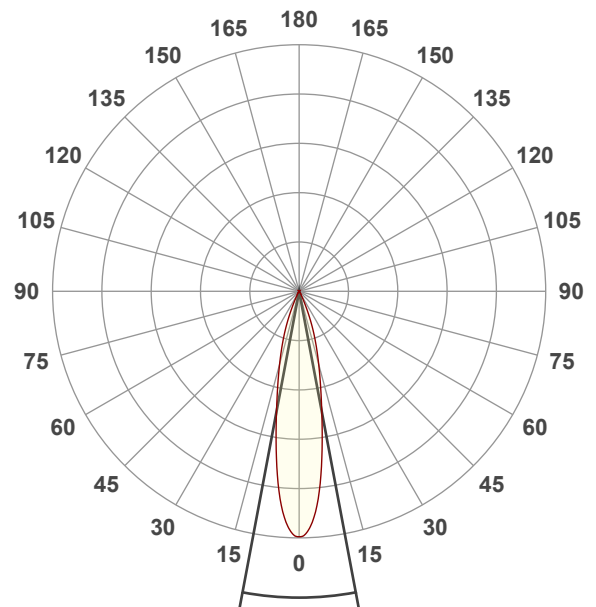

Beam angle 50%: 21,3°

Field angle 10%: 44,7°

Cut off angle 2.5%: 54°

Spectra

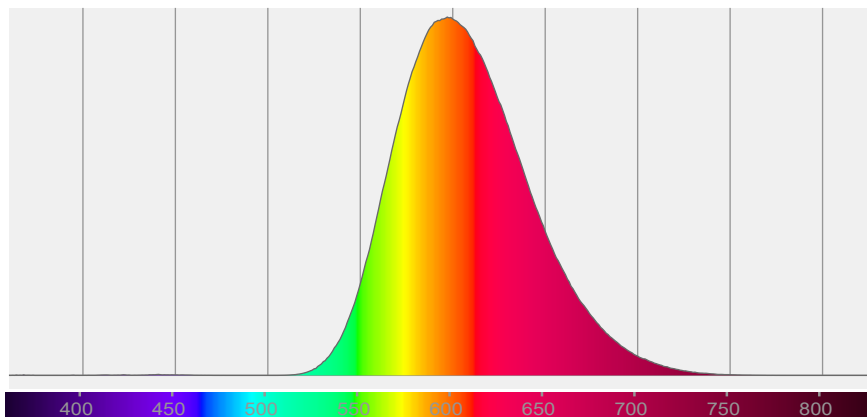

# BEAM DETAILS



Beam angle 50%	Field angle 10%	Cut off angle 2,5%	Intensity ratio in 120° cone	Intensity ratio in 90° cone
21,3°	44,7°	54°	100,0%	99,9%

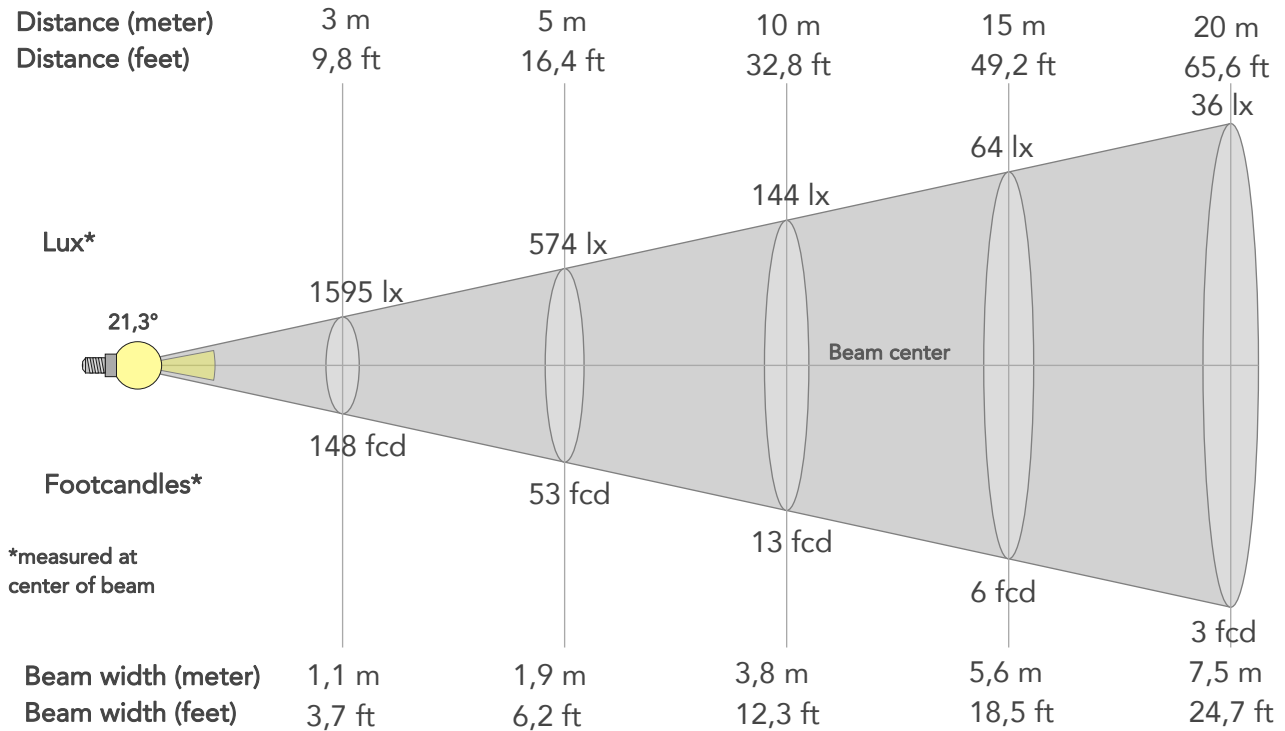

## BEAM INTENSITIES AND WIDTHS

Distance	1m	2m	3m	4m	5m	7,5m	10m	15m	20m	25m	30m	40m	50m
Distance	3,3ft	6,6ft	9,8ft	13,1ft	16,4ft	24,6ft	32,8ft	49,2ft	65,6ft	82ft	98,4ft	131,2ft	164ft
Lux	14358lx	3589lx	1595lx	897lx	574lx	255lx	144lx	64lx	36lx	23lx	16lx	9lx	6lx
Footcand.	1334fcd	333fcd	148fcd	83fcd	53fcd	24fcd	13fcd	6fcd	3fcd	2fcd	1fcd	1fcd	1fcd
Beam wid.	0,4m	0,8m	1,1m	1,5m	1,9m	2,8m	3,8m	5,6m	7,5m	9,4m	11,3m	15m	18,8m
Beam wid.	1,2ft	2,5ft	3,7ft	4,9ft	6,2ft	9,3ft	12,3ft	18,5ft	24,7ft	30,8ft	37ft	49,4ft	61,7ft

## LINEAR DISTRIBUTION DIAGRAM

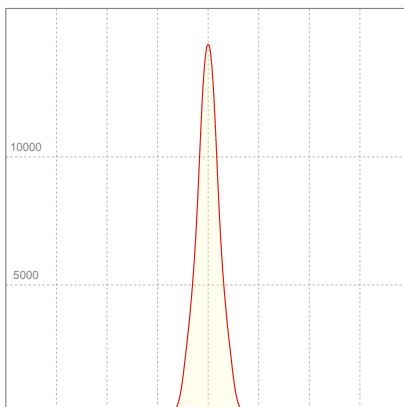

## ELECTRICAL SPECIFICATIONS

Input voltage	Input current	Input power	Effeciency
227V	0,743A	158,5W	17lm/W

Power FC
0,94

## ISO CANDELA DIAGRAM

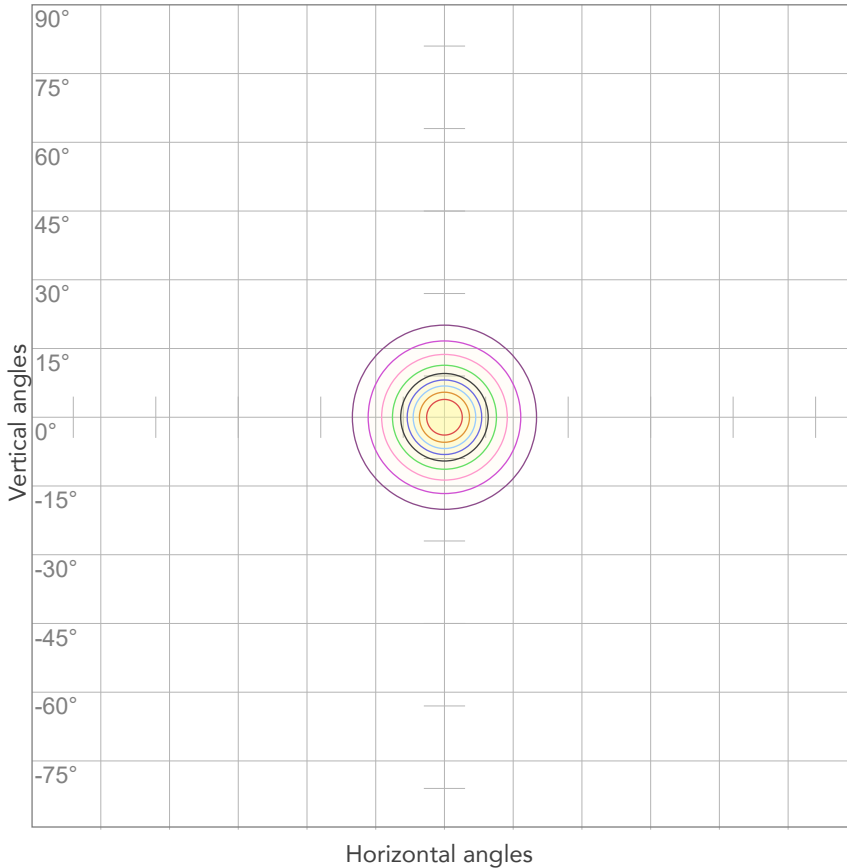

10%	1436 cd
20%	2872 cd
30%	4307 cd
40%	5743 cd
50%	7179 cd
60%	8615 cd
70%	10050 cd
80%	11486 cd

Conditions:

Number of c-planes: 2

Candela at center: 14358 cd

## ISO LUX DIAGRAM

MH: 10,0 m

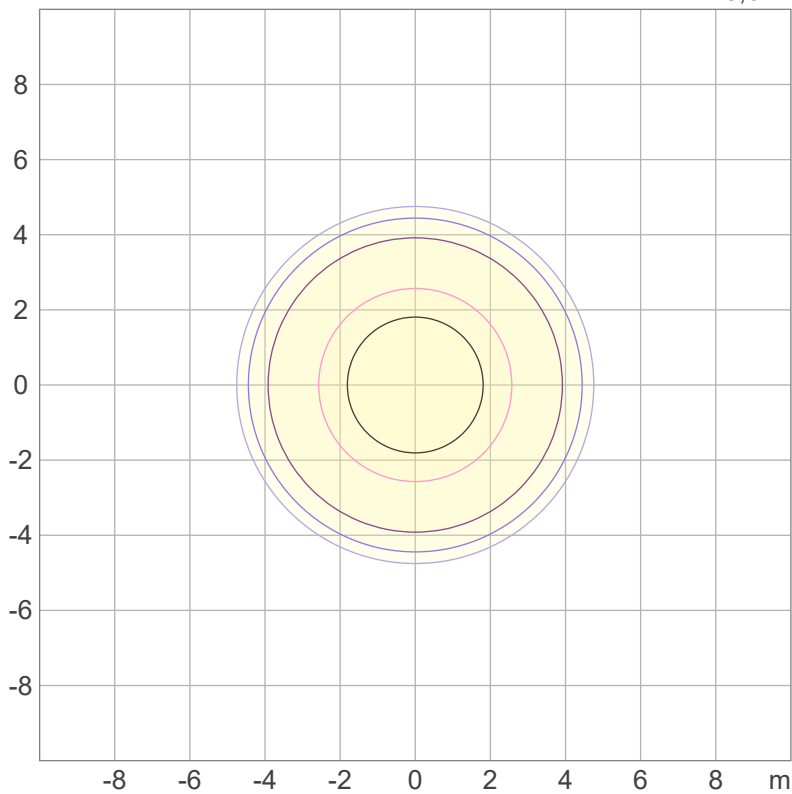

Mounting height: 10 meters (33 feet)

3%	4,31 lx
5%	7,18 lx
10%	14,4 lx
30%	43,1 lx
50%	71,8 lx

Conditions:

Number of c-planes: 2

Lux at center: 144 lx

*Lux distribution on a surface when lamp is mounted at 10 meters from the surface.*





Total lumen output:

1527 lm

Peak candela output:

38212 cd

**PRODUCT NAME:**

**ECLFRCTPLIP**

**MEASURAMENT CONDITIONS:**

Beam angle:

Min Zoom

Target:

Amber - HB

Operator:

Salvatore Giglio

Date and time:

03/10/2023 13:56:37

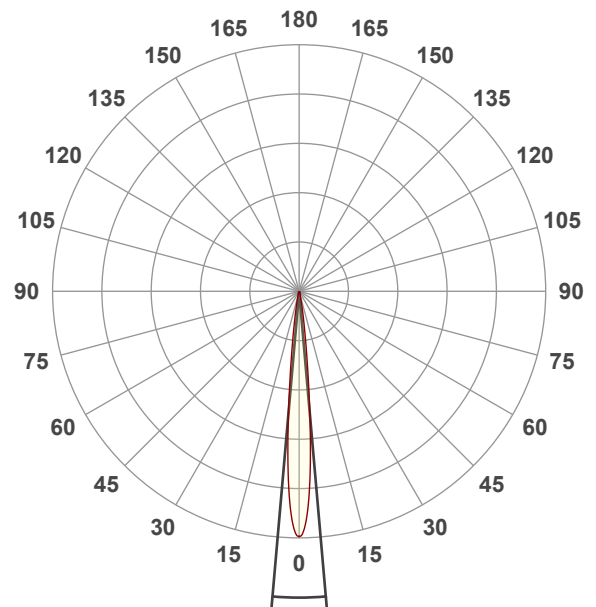

Beam angle 50%: 10°

Field angle 10%: 18,6°

Cut off angle 2.5%: 26,6°

Spectra

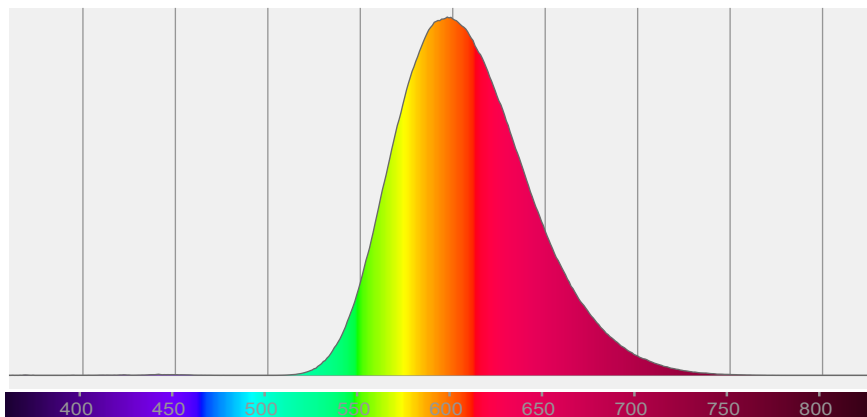

# BEAM DETAILS



Beam angle 50%	Field angle 10%	Cut off angle 2,5%	Intensity ratio in 120° cone	Intensity ratio in 90° cone
10°	18,6°	26,6°	100,0%	100,0%

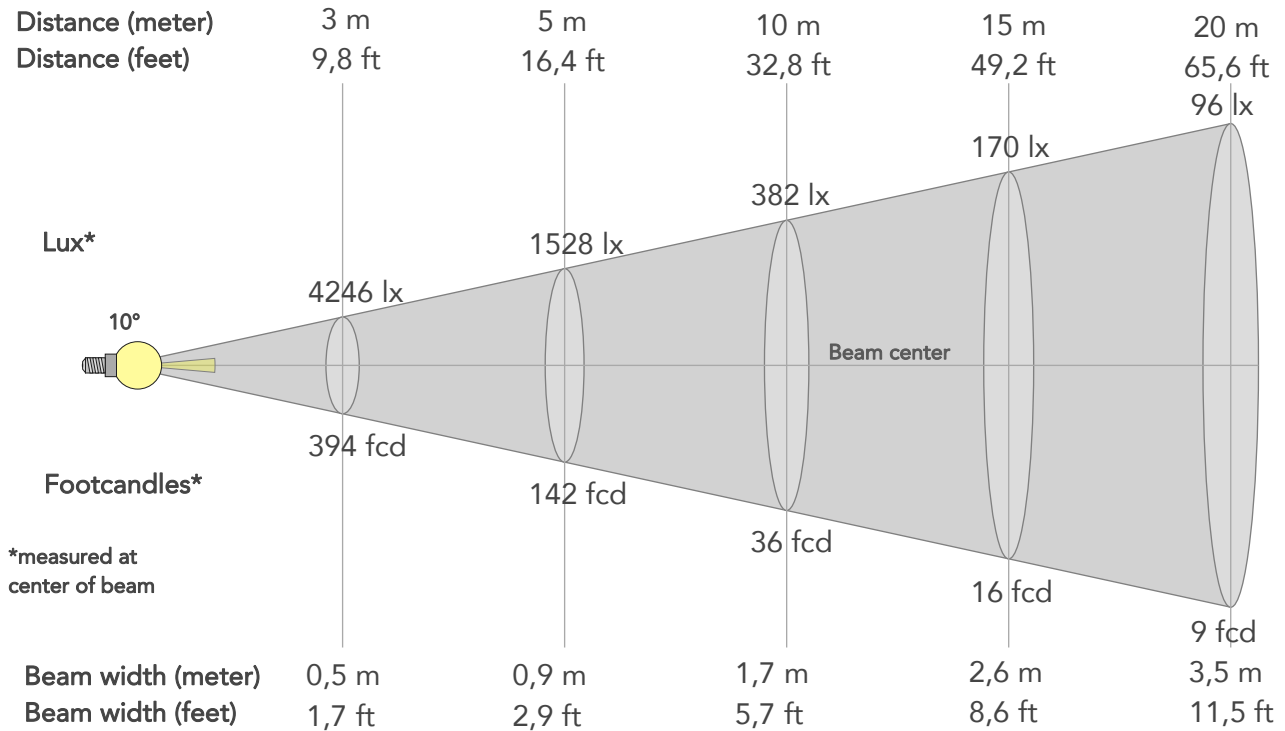

## BEAM INTENSITIES AND WIDTHS

Distance	1m	2m	3m	4m	5m	7,5m	10m	15m	20m	25m	30m	40m	50m
Distance	3,3ft	6,6ft	9,8ft	13,1ft	16,4ft	24,6ft	32,8ft	49,2ft	65,6ft	82ft	98,4ft	131,2ft	164ft
Lux	38212lx	9553lx	4246lx	2388lx	1528lx	679lx	382lx	170lx	96lx	61lx	42lx	24lx	15lx
Footcand.	3550fcd	888fcd	394fcd	222fcd	142fcd	63fcd	36fcd	16fcd	9fcd	6fcd	4fcd	2fcd	1fcd
Beam wid.	0,2m	0,3m	0,5m	0,7m	0,9m	1,3m	1,7m	2,6m	3,5m	4,4m	5,2m	7m	8,7m
Beam wid.	0,6ft	1,2ft	1,7ft	2,3ft	2,9ft	4,3ft	5,7ft	8,6ft	11,5ft	14,3ft	17,2ft	22,9ft	28,7ft

## LINEAR DISTRIBUTION DIAGRAM

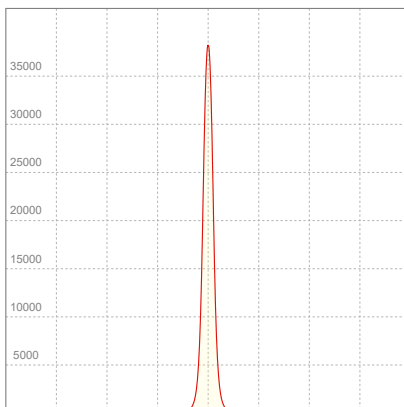

## ELECTRICAL SPECIFICATIONS

Input voltage	Input current	Input power	Effeciency
228V	0,739A	159,3W	10lm/W

Power FC
0,95

## ISO CANDELA DIAGRAM

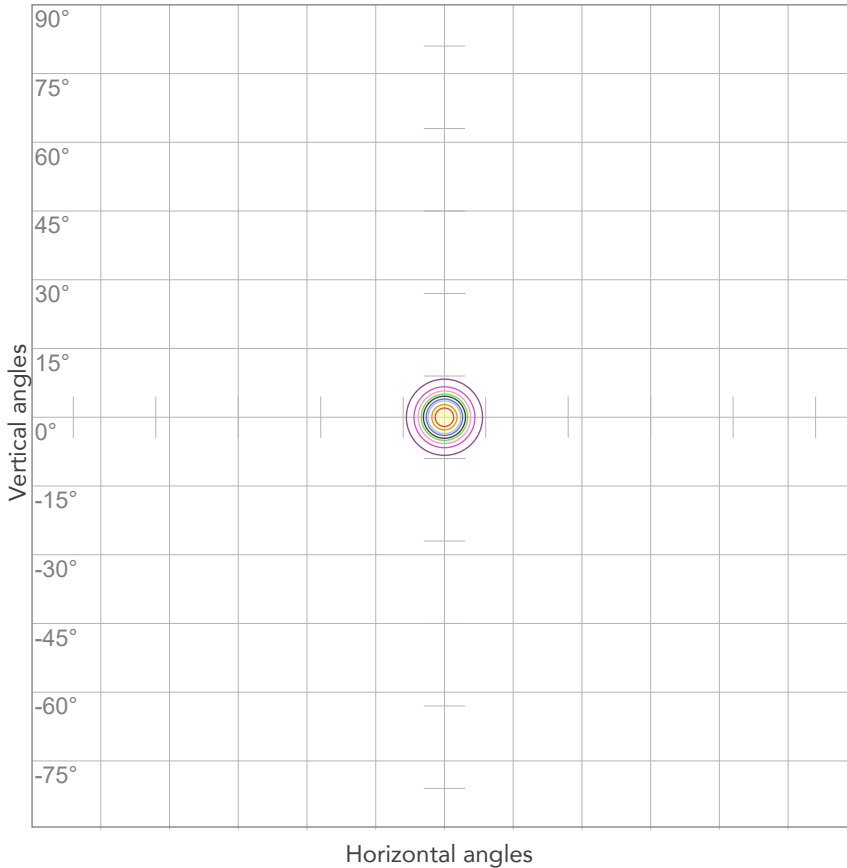

10%	3821 cd
20%	7642 cd
30%	11464 cd
40%	15285 cd
50%	19106 cd
60%	22927 cd
70%	26748 cd
80%	30570 cd

Conditions:

Number of c-planes: 2

Candela at center: 38212 cd

## ISO LUX DIAGRAM

MH: 10,0 m

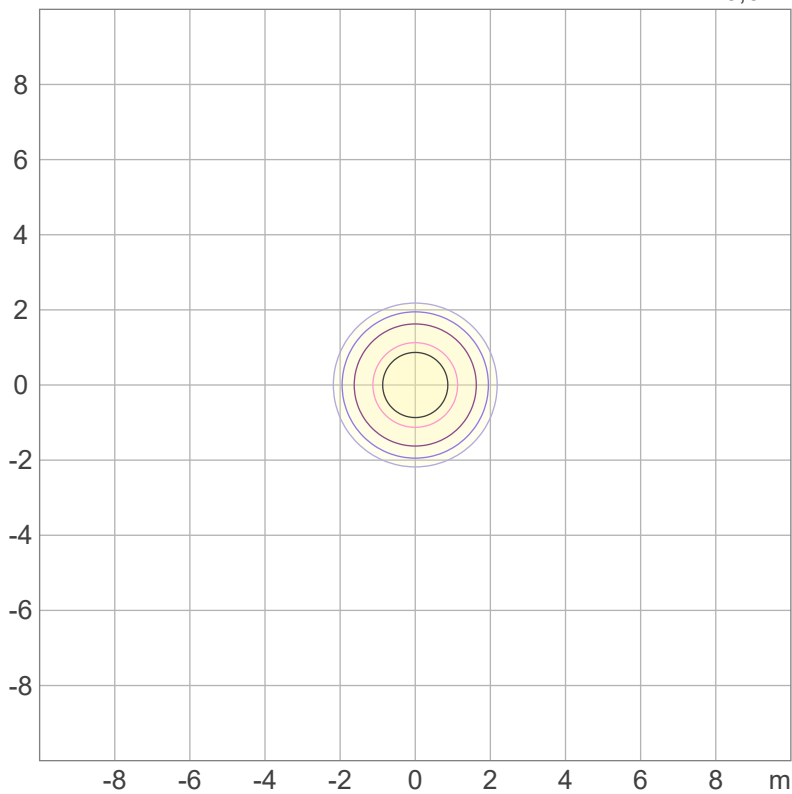

Mounting height: 10 meters (33 feet)

3%	11,5 lx
5%	19,1 lx
10%	38,2 lx
30%	115 lx
50%	191 lx

Conditions:

Number of c-planes: 2

Lux at center: 382 lx

*Lux distribution on a surface when lamp is mounted at 10 meters from the surface.*



Total lumen output:

12204 lm

Peak candela output:

16368 cd

Light quality:

CRI: 93,2

Color temperature:

2820 K

**PRODUCT NAME:**  
**ECLFRCTPLIP**

**MEASURAMENT CONDITIONS:**

Beam angle:

Max Zoom

Target:

2800K - HB

Operator:

Salvatore Giglio

Date and time:

03/10/2023 13:15:10

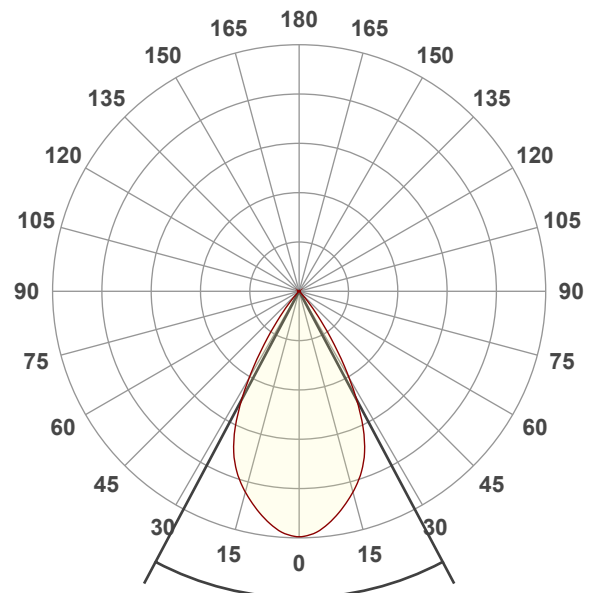

Beam angle 50%: 55,9°

Field angle 10%: 76,7°

Cut off angle 2.5%: 85,6°

Spectra

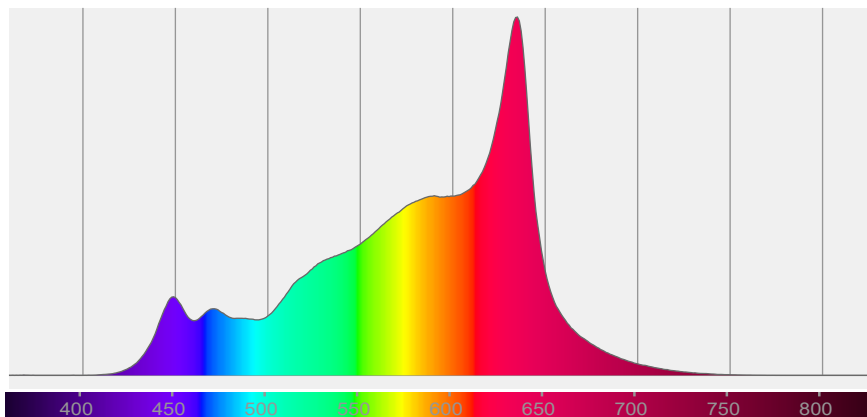

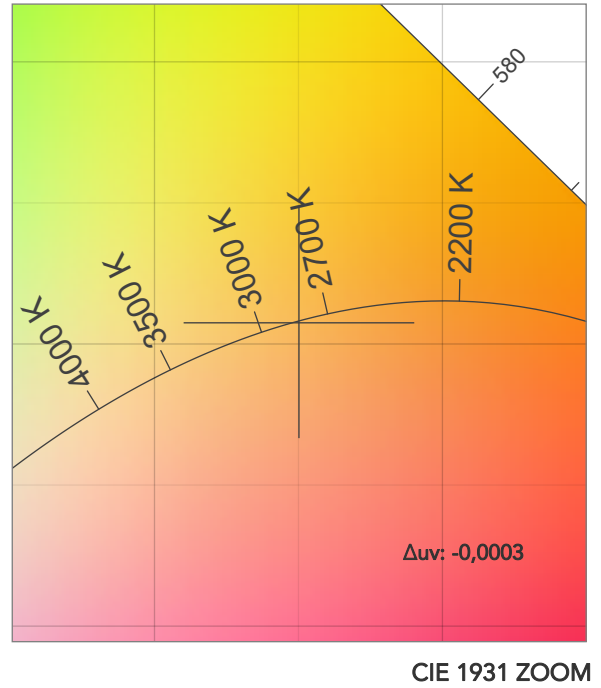
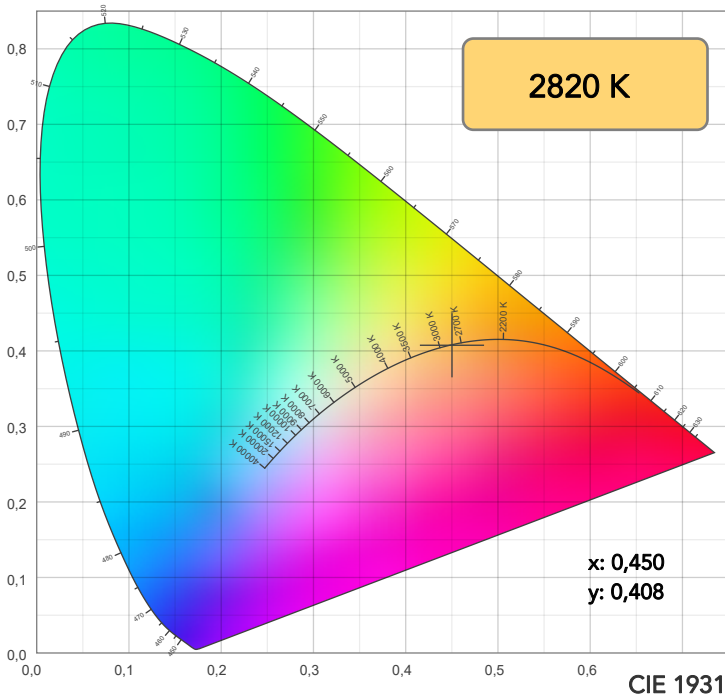

TM30: 91,1

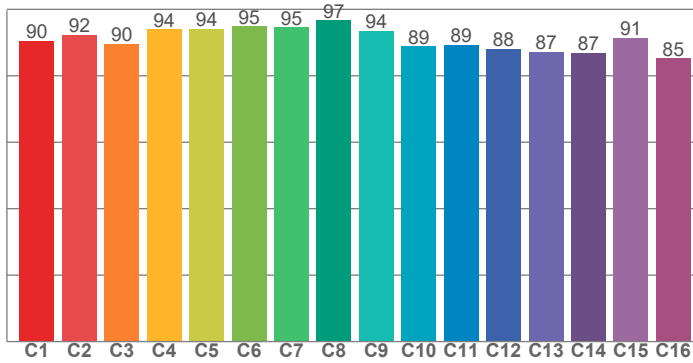

CRI: 93,2 (R1-R8)

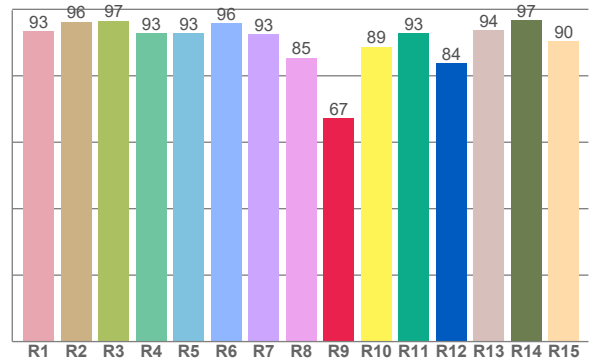

CQS: 90,6

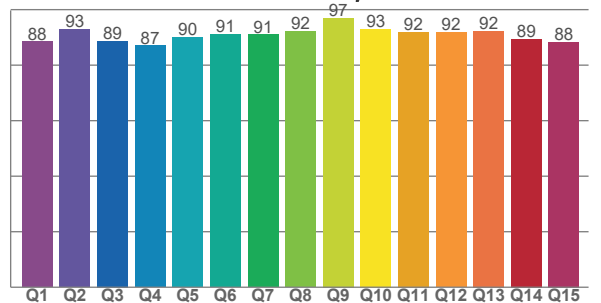

CRI R values, only R1-R8 are used to calculate final CRI value

R1	R2	R3	R4	R5	R6	R7	R8	R9	R10	R11	R12	R13	R14	R15
93,5	96,3	96,6	92,8	92,7	95,9	92,6	85,4	67,3	88,8	92,7	83,7	93,8	96,6	90,4

TM30 C values, 16 binned values out of total of 99 C values

C1	C2	C3	C4	C5	C6	C7	C8	C9	C10	C11	C12	C13	C14	C15	C16
90,5	92,3	89,7	94,0	94,2	94,8	94,5	96,6	93,6	88,9	89,3	88,1	87,2	86,8	91,4	85,2

CQS Q values

Q1	Q2	Q3	Q4	Q5	Q6	Q7	Q8	Q9	Q10	Q11	Q12	Q13	Q14	Q15
88,4	92,9	88,7	87,1	90,0	91,1	91,0	92,2	97,0	93,1	91,9	91,8	92,3	89,4	88,3

COLOR PARAMETERS

Color temperature	Color rendering index	Red component	Color fidelity	Color gamut	Color quality scale	Television lighting index	Color coordinate cie 1931	Color coordinate cie 1931	Color deviation from black body
CCT	CRI	CRI R9	TM30 Rf	TM30 Rg	CQS	TLCI	x	y	Δuv
2820 K	93,2	67,3	91,1	98,8	90,6	83	0,450	0,408	-0,0003

# TM30 DETAILS

**Rf 91,1**  
Fidelity index Rf

**Rg 98,8**  
Gammut index

Hue Bin	R <sub>f</sub>	Graphic shifts (%)	
		Chroma	Hue
1	90	-5%	0%
2	92	-3%	3%
3	90	-2%	5%
4	94	-1%	2%
5	94	1%	3%
6	95	2%	0%
7	95	-2%	-1%
8	97	-2%	0%
9	94	-2%	3%
10	89	-1%	7%
11	89	2%	8%
12	88	5%	-1%
13	87	3%	-9%
14	87	4%	-10%
15	91	-2%	-5%
16	85	-4%	-11%

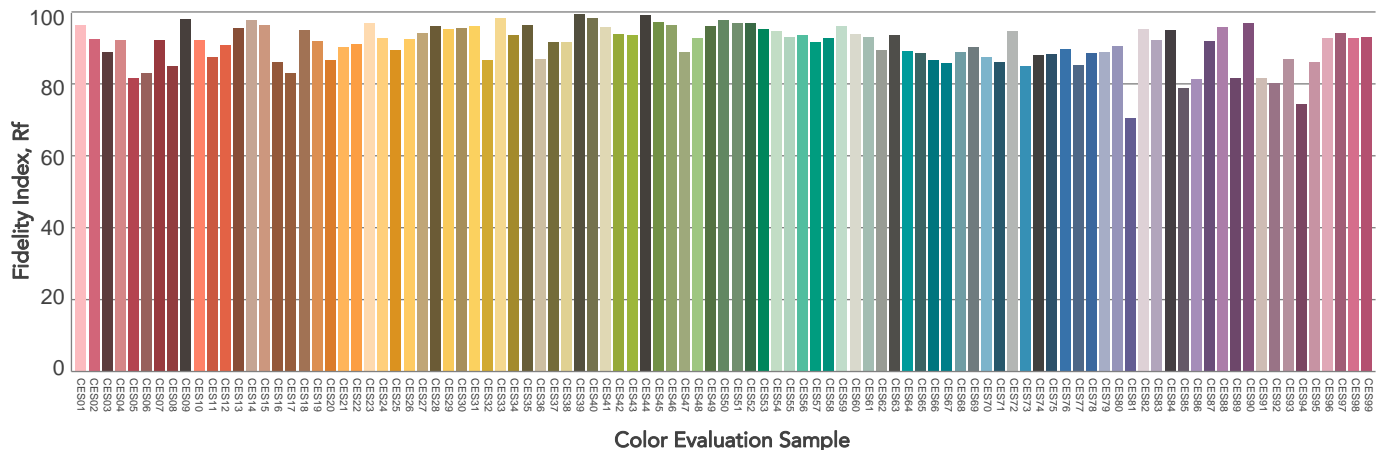
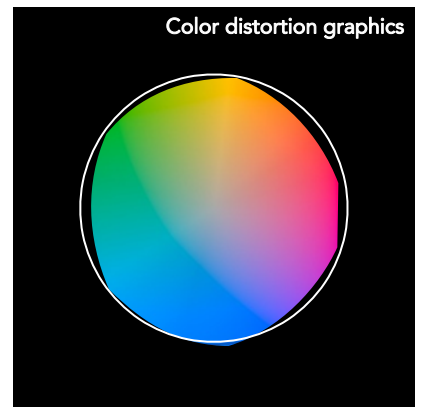
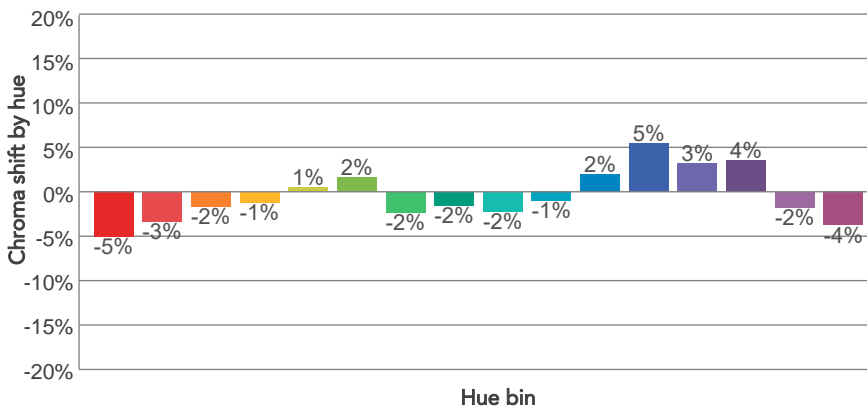
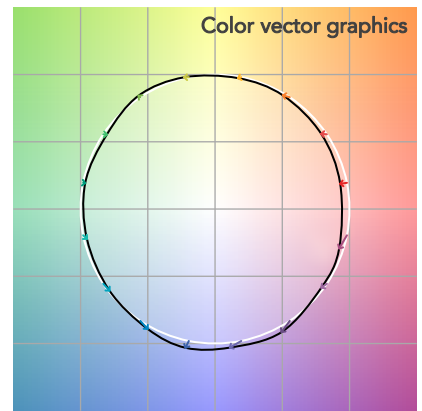
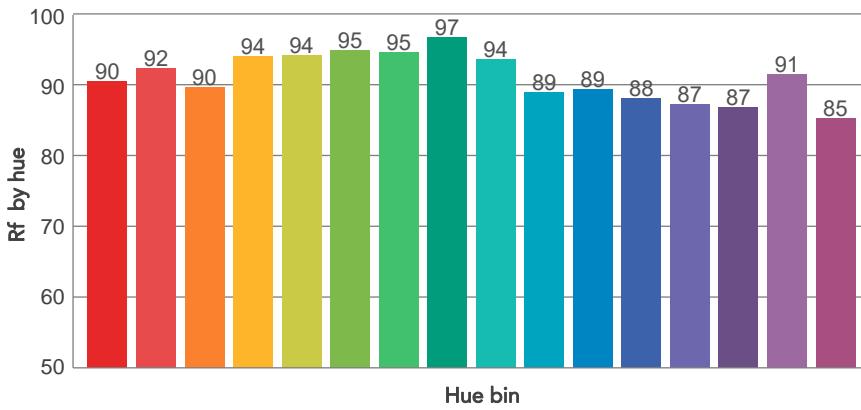
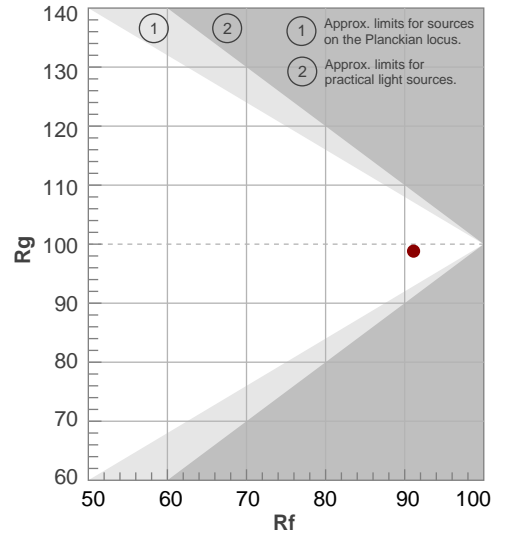

# BEAM DETAILS



Beam angle 50%	Field angle 10%	Cut off angle 2,5%	Intensity ratio in 120° cone	Intensity ratio in 90° cone
55,9°	76,7°	85,6°	100,0%	99,8%

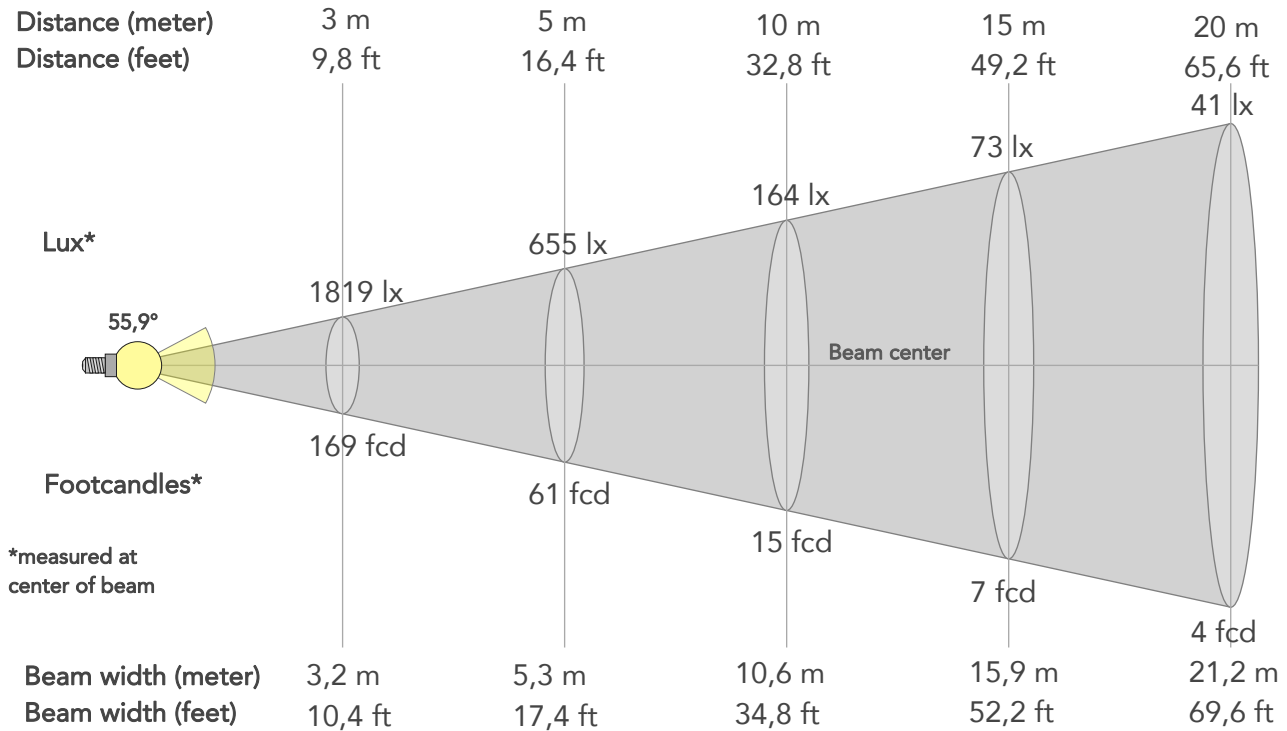

## BEAM INTENSITIES AND WIDTHS

Distance	1m	2m	3m	4m	5m	7,5m	10m	15m	20m	25m	30m	40m	50m
Distance	3,3ft	6,6ft	9,8ft	13,1ft	16,4ft	24,6ft	32,8ft	49,2ft	65,6ft	82ft	98,4ft	131,2ft	164ft
Lux	16368lx	4092lx	1819lx	1023lx	655lx	291lx	164lx	73lx	41lx	26lx	18lx	10lx	7lx
Footcand.	1521fcd	380fcd	169fcd	95fcd	61fcd	27fcd	15fcd	7fcd	4fcd	2fcd	2fcd	1fcd	1fcd
Beam wid.	1,1m	2,1m	3,2m	4,2m	5,3m	8m	10,6m	15,9m	21,2m	26,5m	31,8m	42,4m	53,1m
Beam wid.	3,5ft	7ft	10,4ft	13,9ft	17,4ft	26,1ft	34,8ft	52,2ft	69,6ft	87ft	104,4ft	139,2ft	174ft

## LINEAR DISTRIBUTION DIAGRAM

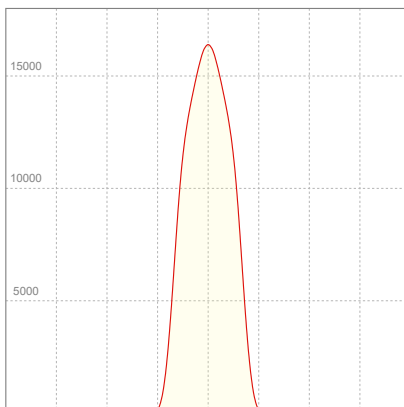

## ELECTRICAL SPECIFICATIONS

Input voltage	Input current	Input power	Effeciency
227V	1,99A	449,9W	27lm/W

## ISO CANDELA DIAGRAM

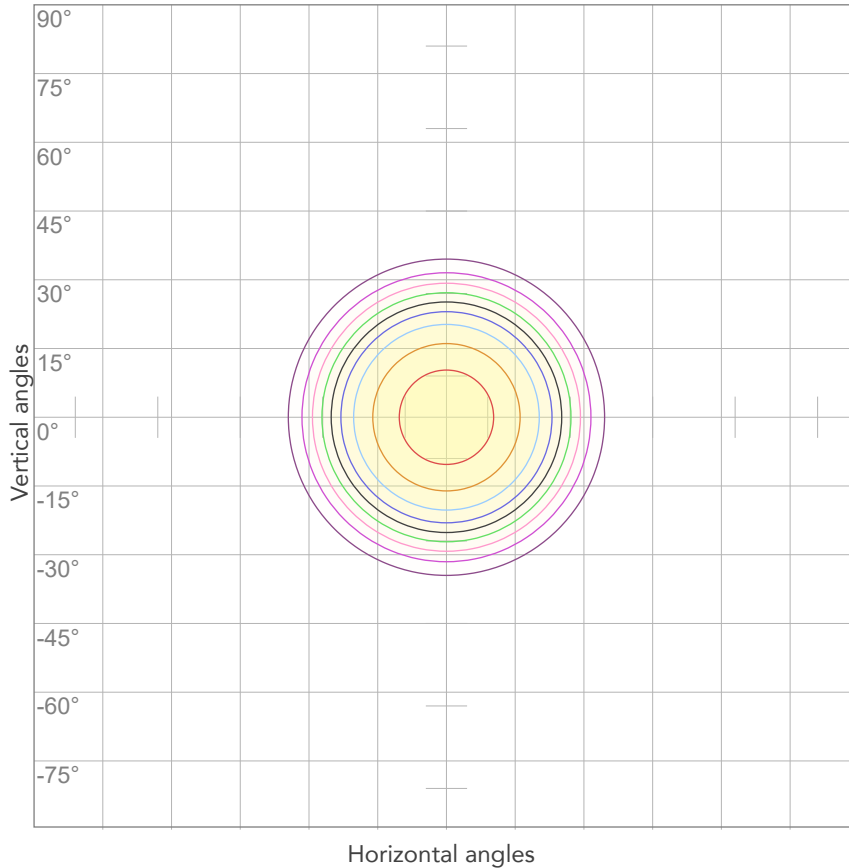

10%	1637 cd
20%	3274 cd
30%	4910 cd
40%	6547 cd
50%	8184 cd
60%	9821 cd
70%	11458 cd
80%	13095 cd

Conditions:

Number of c-planes: 2

Candela at center: 16368 cd

## ISO LUX DIAGRAM

MH: 10,0 m

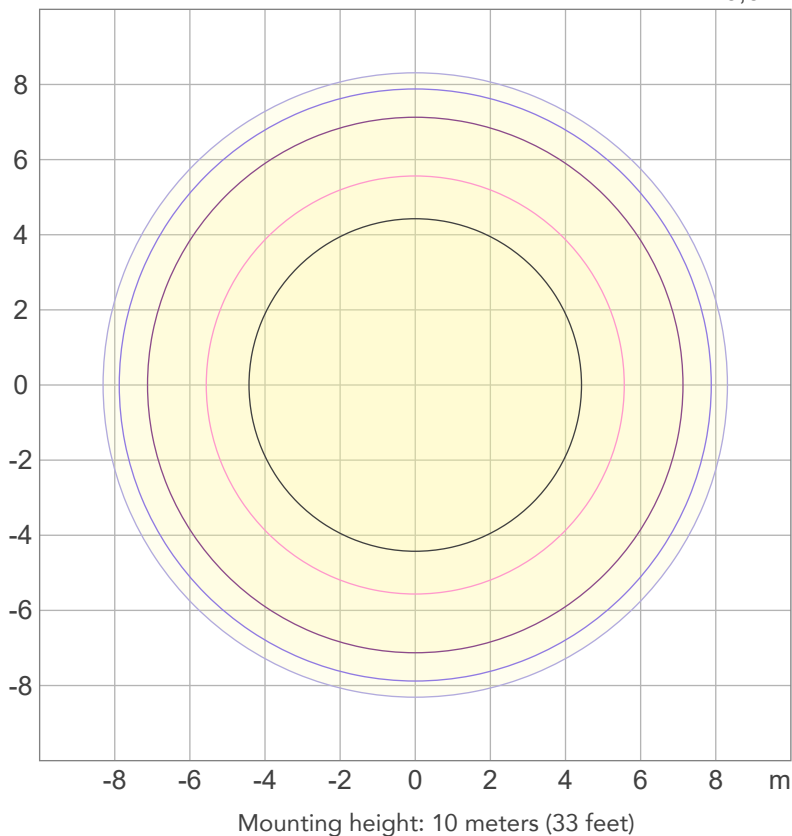

3%	4,91 lx
5%	8,18 lx
10%	16,4 lx
30%	49,1 lx
50%	81,8 lx

Conditions:

Number of c-planes: 2

Lux at center: 164 lx

*Lux distribution on a surface when lamp is mounted at 10 meters from the surface.*





Total lumen output:

9858 lm

Peak candela output:

53083 cd

Light quality:

CRI: 92,8

Color temperature:

2832 K

**PRODUCT NAME:**

**ECLFRCTPLIP**

**MEASURAMENT CONDITIONS:**

Beam angle:

Med Zoom

Target:

2800K - HB

Operator:

Salvatore Giglio

Date and time:

03/10/2023 14:24:38

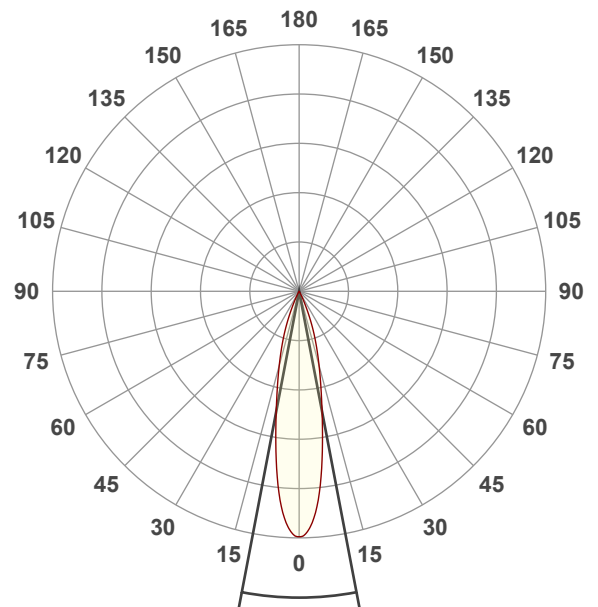

Beam angle 50%: 21,6°

Field angle 10%: 44,8°

Cut off angle 2.5%: 53,5°

Spectra

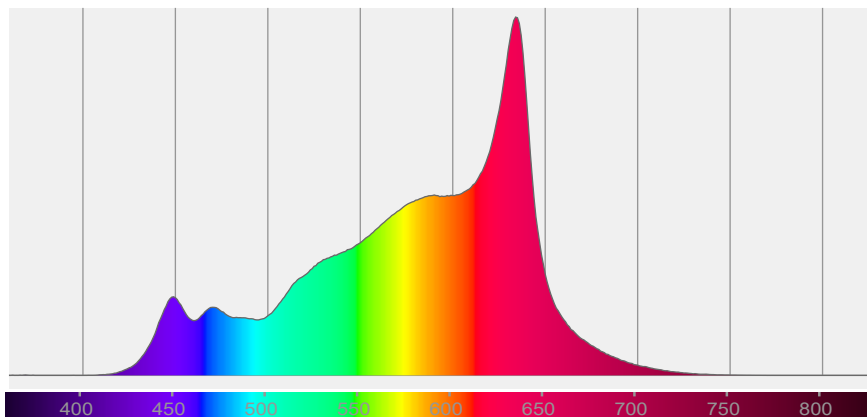

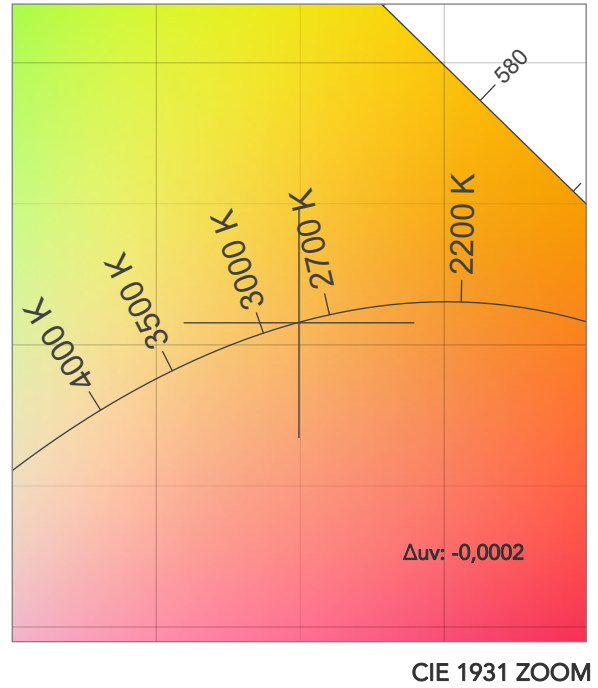
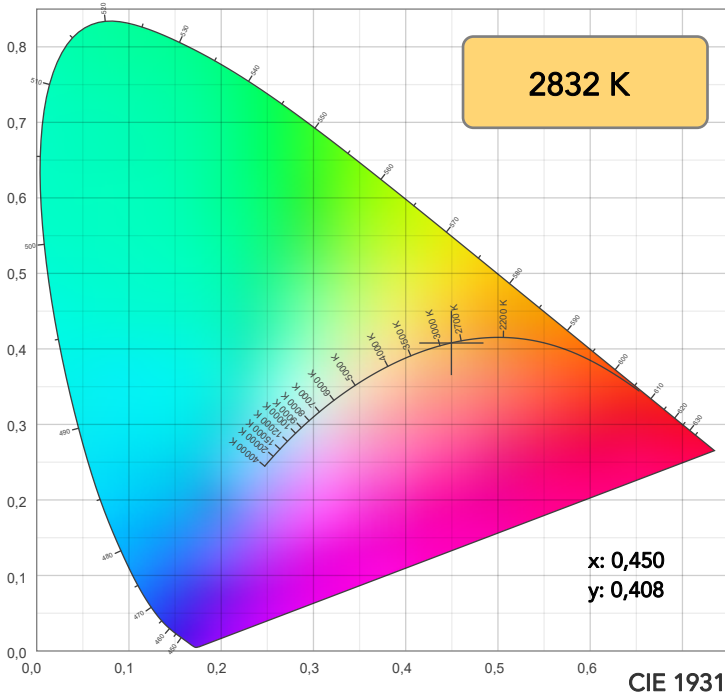

TM30: 90,9

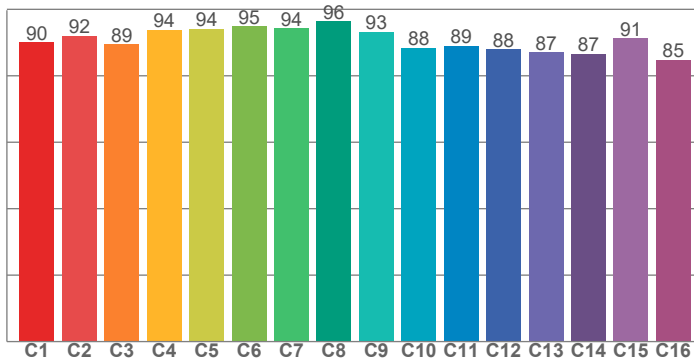

CRI: 92,8 (R1-R8)

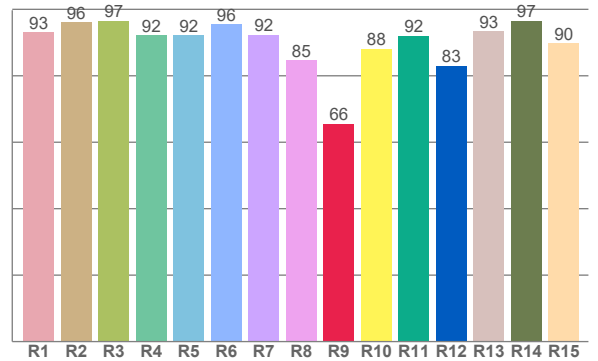

CRI R values, only R1-R8 are used to calculate final CRI value

R1	R2	R3	R4	R5	R6	R7	R8	R9	R10	R11	R12	R13	R14	R15
93,0	96,0	96,5	92,3	92,2	95,6	92,4	84,7	65,6	88,1	92,1	83,0	93,4	96,6	89,9

TM30 C values, 16 binned values out of total of 99 C values

C1	C2	C3	C4	C5	C6	C7	C8	C9	C10	C11	C12	C13	C14	C15	C16
90,1	92,0	89,5	93,9	94,1	94,9	94,3	96,3	93,2	88,4	88,9	88,0	87,0	86,6	91,2	84,8

CQS Q values

Q1	Q2	Q3	Q4	Q5	Q6	Q7	Q8	Q9	Q10	Q11	Q12	Q13	Q14	Q15
88,1	92,9	88,6	86,7	89,6	90,7	90,8	92,2	96,9	93,0	91,7	91,7	92,1	88,9	87,9

CQS: 90,4

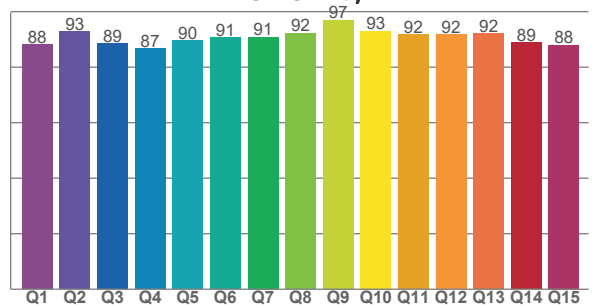

COLOR PARAMETERS

Color temperature	Color rendering index	Red component	Color fidelity	Color gamut	Color quality scale	Television lighting index	Color coordinate cie 1931	Color coordinate cie 1931	Color deviation from black body
CCT	CRI	CRI R9	TM30 Rf	TM30 Rg	CQS	TLCI	x	y	Δuv
2832 K	92,8	65,6	90,9	98,5	90,4	83	0,450	0,408	-0,0002

# TM30 DETAILS

**Rf 90,9**  
Fidelity index Rf

**Rg 98,5**  
Gammut index

Hue Bin	R <sub>f</sub>	Graphic shifts (%)	
		Chroma	Hue
1	90	-5%	0%
2	92	-3%	3%
3	89	-2%	5%
4	94	-1%	2%
5	94	0%	3%
6	95	1%	0%
7	94	-3%	-1%
8	96	-2%	0%
9	93	-2%	3%
10	88	-1%	7%
11	89	2%	8%
12	88	5%	-1%
13	87	3%	-9%
14	87	4%	-10%
15	91	-2%	-5%
16	85	-4%	-11%

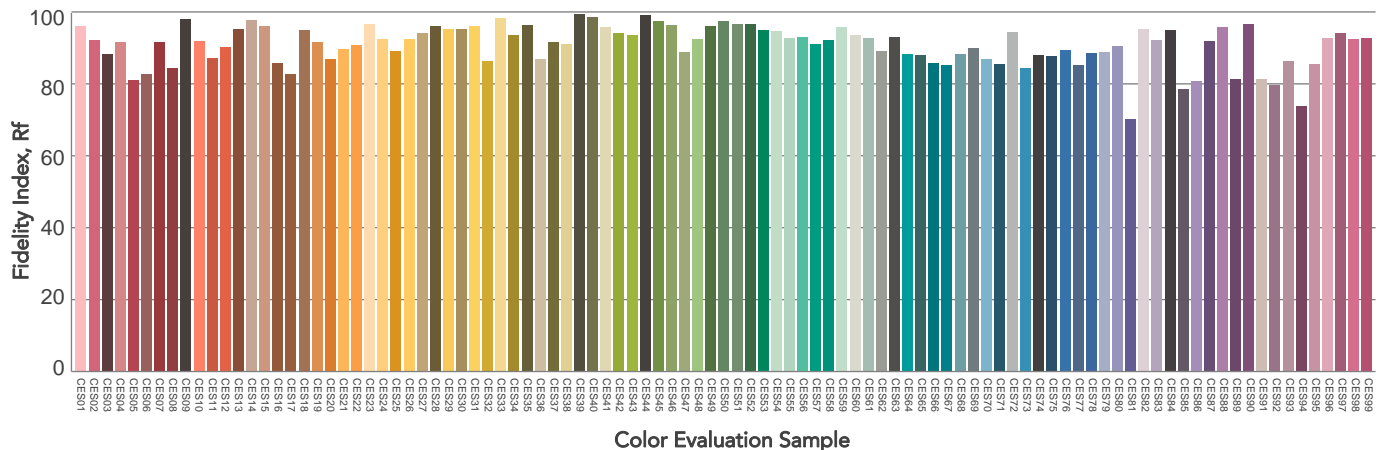
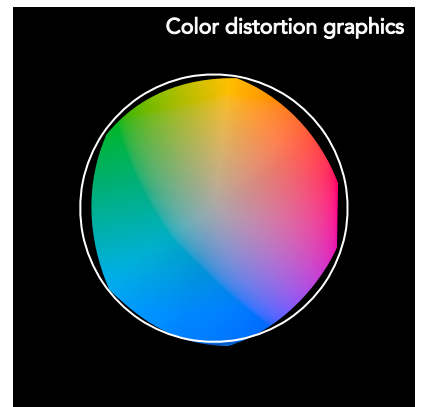
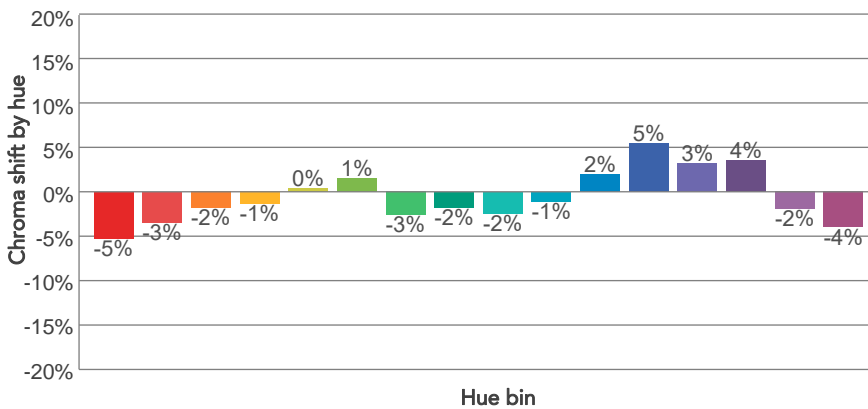
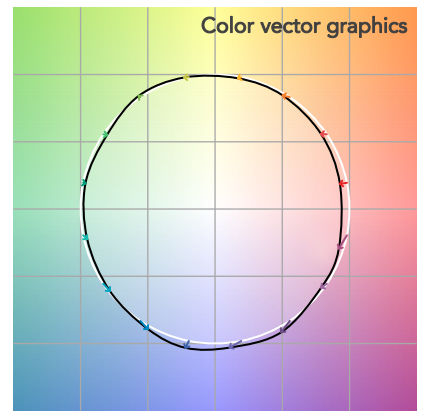
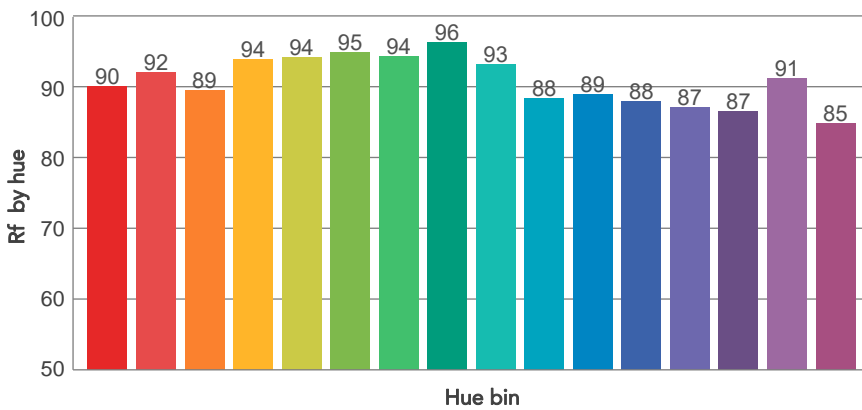
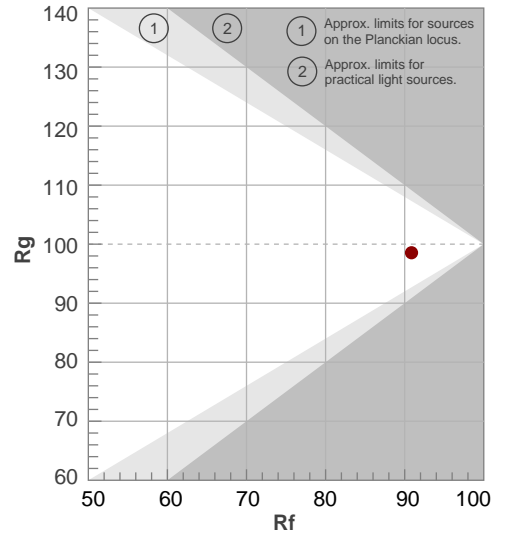

# BEAM DETAILS



Beam angle 50%	Field angle 10%	Cut off angle 2,5%	Intensity ratio in 120° cone	Intensity ratio in 90° cone
21,6°	44,8°	53,5°	100,0%	100,0%

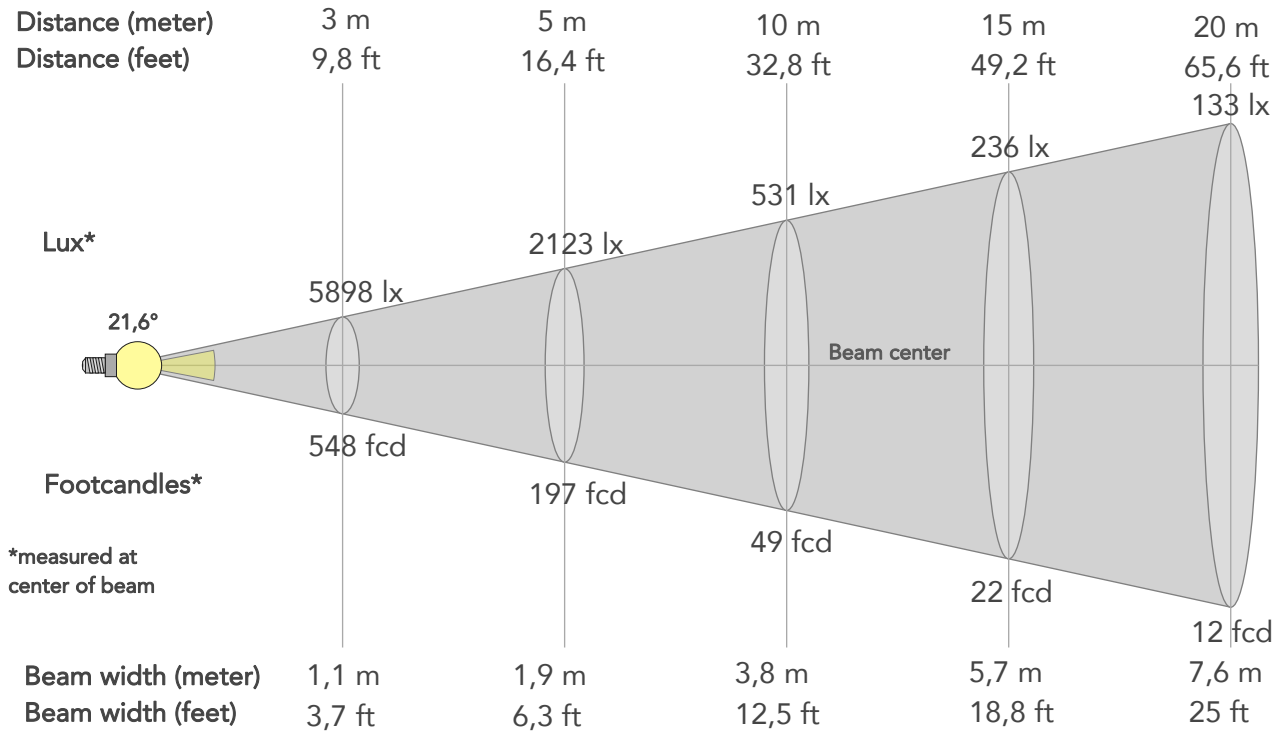

## BEAM INTENSITIES AND WIDTHS

Distance	1m	2m	3m	4m	5m	7,5m	10m	15m	20m	25m	30m	40m	50m
Distance	3,3ft	6,6ft	9,8ft	13,1ft	16,4ft	24,6ft	32,8ft	49,2ft	65,6ft	82ft	98,4ft	131,2ft	164ft
Lux	53083lx	13271lx	5898lx	3318lx	2123lx	944lx	531lx	236lx	133lx	85lx	59lx	33lx	21lx
Footcand.	4932fcd	1233fcd	548fcd	308fcd	197fcd	88fcd	49fcd	22fcd	12fcd	8fcd	5fcd	3fcd	2fcd
Beam wid.	0,4m	0,8m	1,1m	1,5m	1,9m	2,9m	3,8m	5,7m	7,6m	9,5m	11,4m	15,2m	19,1m
Beam wid.	1,3ft	2,5ft	3,7ft	5ft	6,3ft	9,4ft	12,5ft	18,8ft	25ft	31,3ft	37,5ft	50ft	62,5ft

## LINEAR DISTRIBUTION DIAGRAM

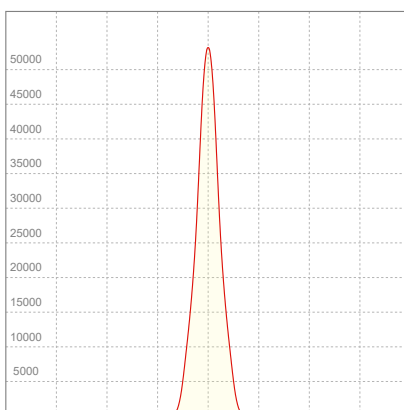

## ELECTRICAL SPECIFICATIONS

Input voltage	Input current	Input power	Effeciency
225V	1,99A	444,7W	22lm/W

## ISO CANDELA DIAGRAM

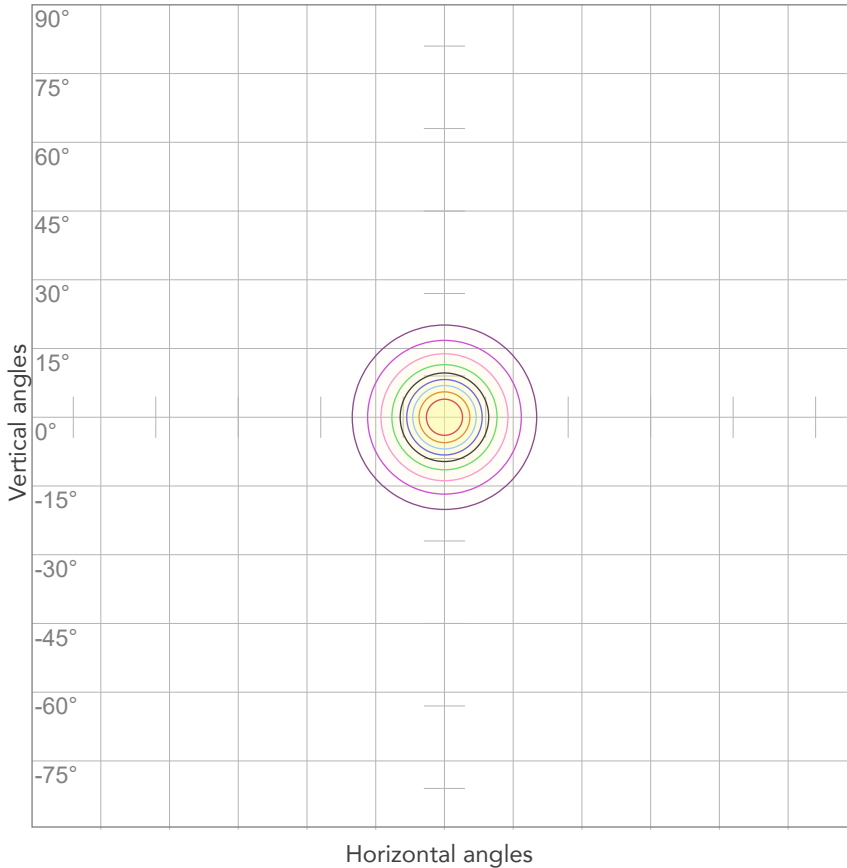

10%	5308 cd
20%	10617 cd
30%	15925 cd
40%	21233 cd
50%	26542 cd
60%	31850 cd
70%	37158 cd
80%	42467 cd

Conditions:

Number of c-planes: 2

Candela at center: 53083 cd

## ISO LUX DIAGRAM

MH: 10,0 m

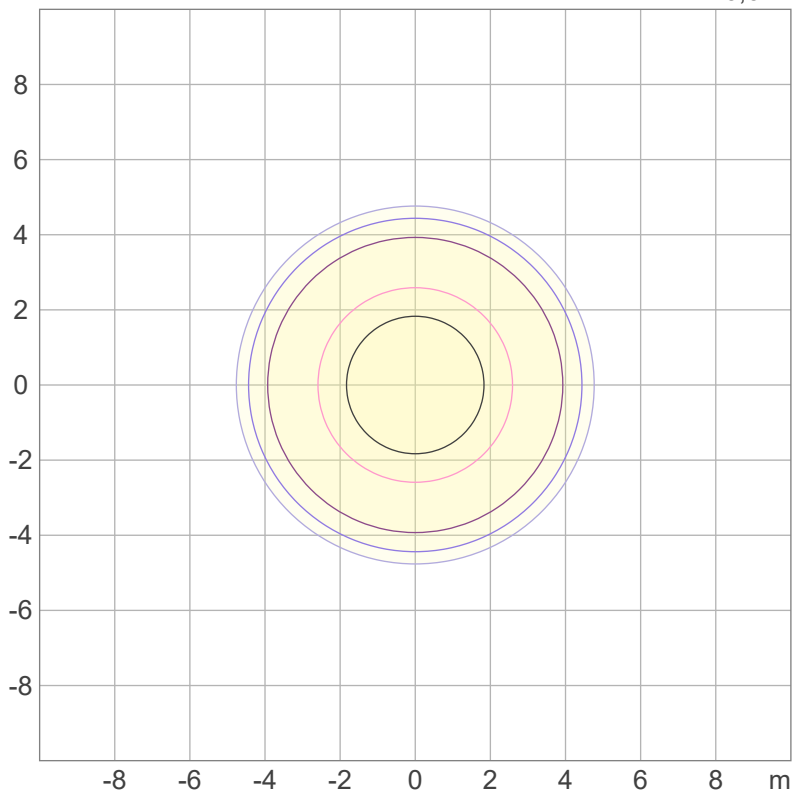

Mounting height: 10 meters (33 feet)

3%	15,9 lx
5%	26,5 lx
10%	53,1 lx
30%	159 lx
50%	265 lx

Conditions:

Number of c-planes: 2

Lux at center: 531 lx

*Lux distribution on a surface when lamp is mounted at 10 meters from the surface.*



Total lumen output:

5364 lm

Peak candela output:

139405 cd

Light quality:

CRI: 92,5

Color temperature:

2843 K

**PRODUCT NAME:**  
**ECLFRCTPLIP**

**MEASURAMENT CONDITIONS:**

Beam angle:

Min Zoom

Target:

2800K - HB

Operator:

Salvatore Giglio

Date and time:

03/10/2023 14:21:54

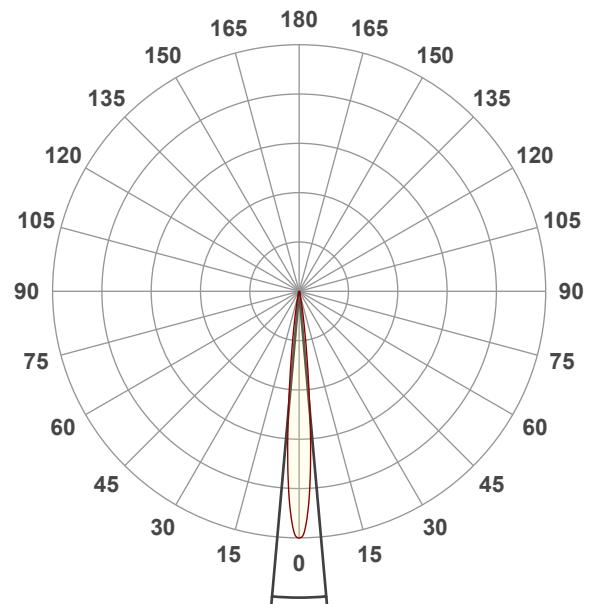

Beam angle 50%: 10,2°

Field angle 10%: 18,7°

Cut off angle 2.5%: 25,9°

Spectra

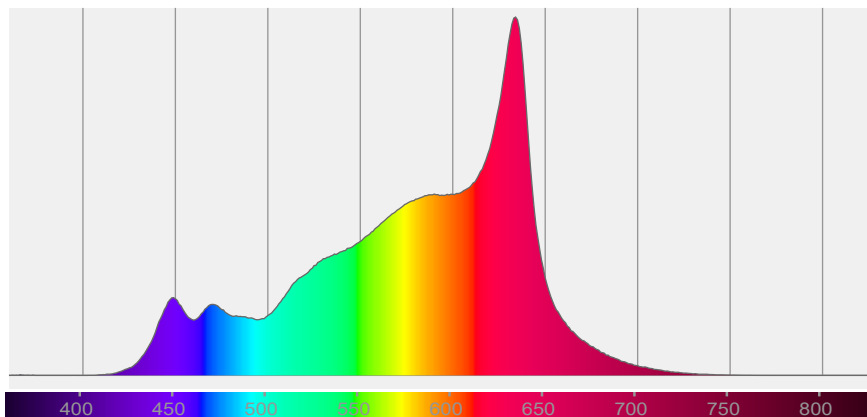

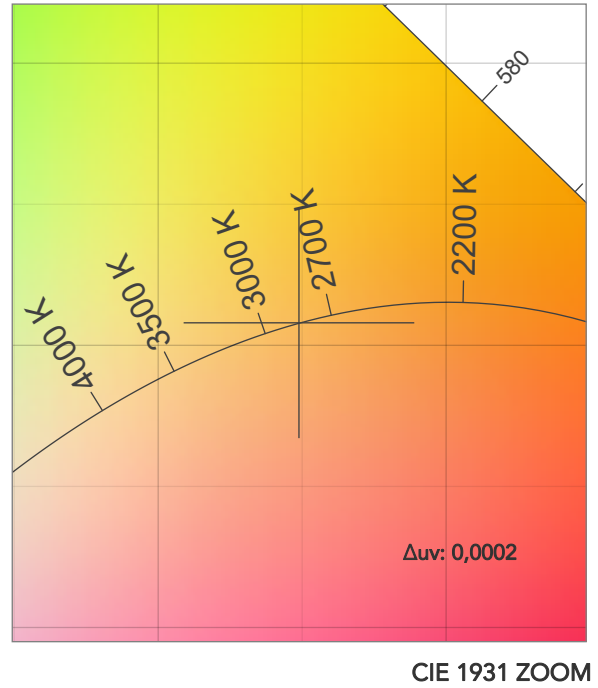
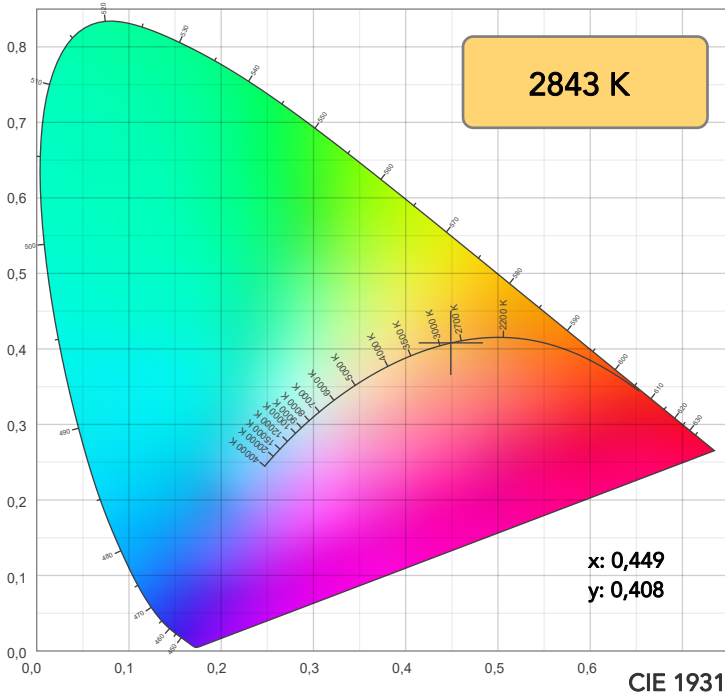

TM30: 90,6

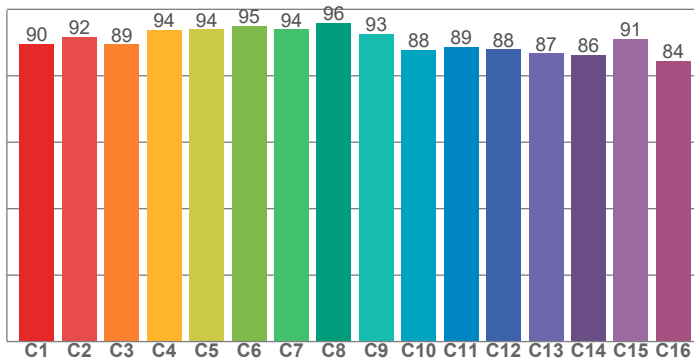

CRI: 92,5 (R1-R8)

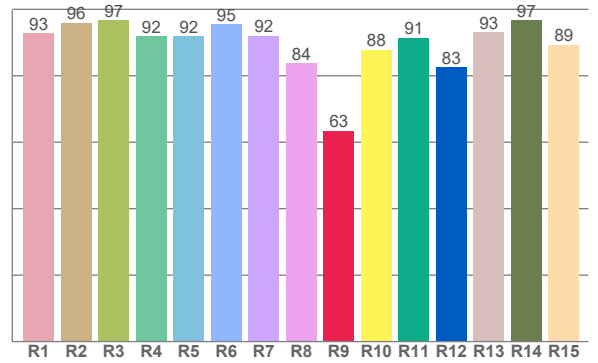

CQS: 90,1

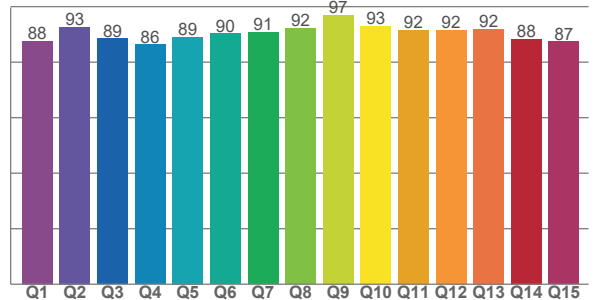

CRI R values, only R1-R8 are used to calculate final CRI value

R1	R2	R3	R4	R5	R6	R7	R8	R9	R10	R11	R12	R13	R14	R15
92,7	95,9	96,7	91,8	91,9	95,5	92,0	83,8	63,5	87,8	91,4	82,5	93,1	96,7	89,4

TM30 C values, 16 binned values out of total of 99 C values

C1	C2	C3	C4	C5	C6	C7	C8	C9	C10	C11	C12	C13	C14	C15	C16
89,6	91,7	89,4	93,7	94,0	95,0	94,0	96,0	92,7	87,8	88,6	87,9	86,7	86,2	91,0	84,4

CQS Q values

Q1	Q2	Q3	Q4	Q5	Q6	Q7	Q8	Q9	Q10	Q11	Q12	Q13	Q14	Q15
87,6	92,7	88,5	86,4	89,1	90,3	90,8	92,2	96,9	93,0	91,7	91,6	91,9	88,4	87,4

COLOR PARAMETERS

Color temperature	Color rendering index	Red component	Color fidelity	Color gamut	Color quality scale	Television lighting index	Color coordinate cie 1931	Color coordinate cie 1931	Color deviation from black body
CCT	CRI	CRI R9	TM30 Rf	TM30 Rg	CQS	TLCI	x	y	Δuv
2843 K	92,5	63,5	90,6	98,2	90,1	82	0,449	0,408	0,0002

# TM30 DETAILS

**Rf 90,6**  
Fidelity index Rf

**Rg 98,2**  
Gammut index

Hue Bin	R <sub>f</sub>	Graphic shifts (%)	
		Chroma	Hue
1	90	-6%	0%
2	92	-4%	3%
3	89	-2%	5%
4	94	-2%	2%
5	94	0%	3%
6	95	1%	0%
7	94	-3%	-1%
8	96	-2%	0%
9	93	-3%	4%
10	88	-1%	8%
11	89	2%	8%
12	88	6%	-1%
13	87	3%	-10%
14	86	3%	-10%
15	91	-2%	-5%
16	84	-4%	-11%

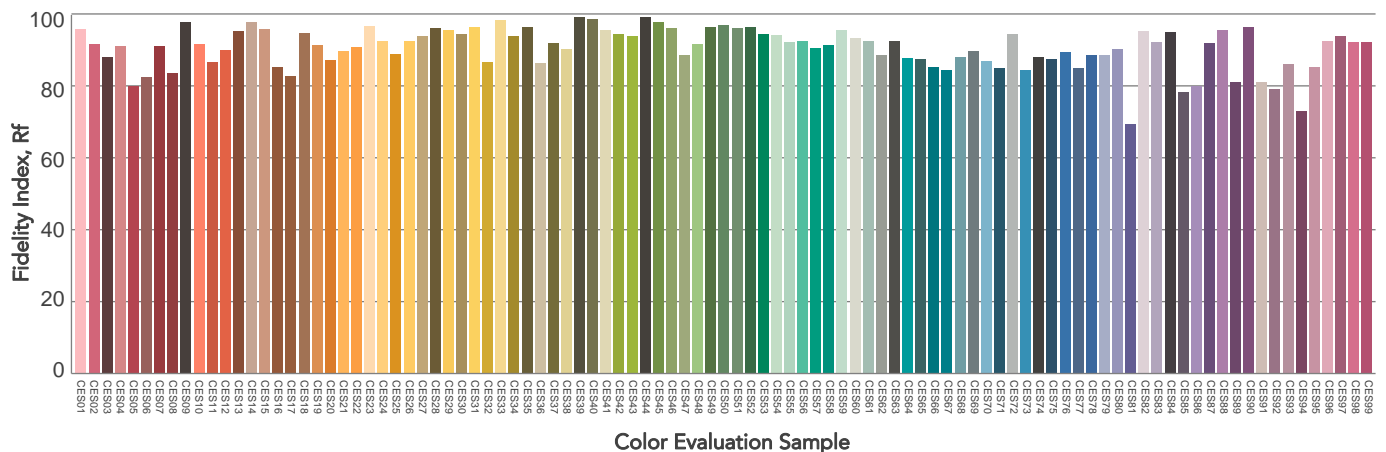
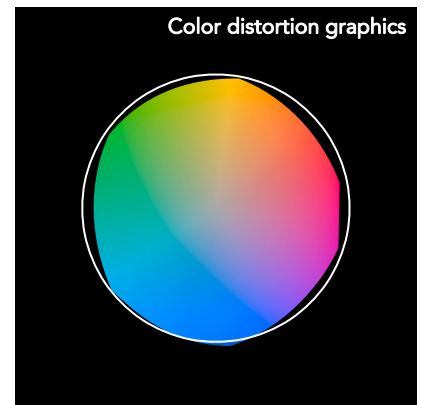
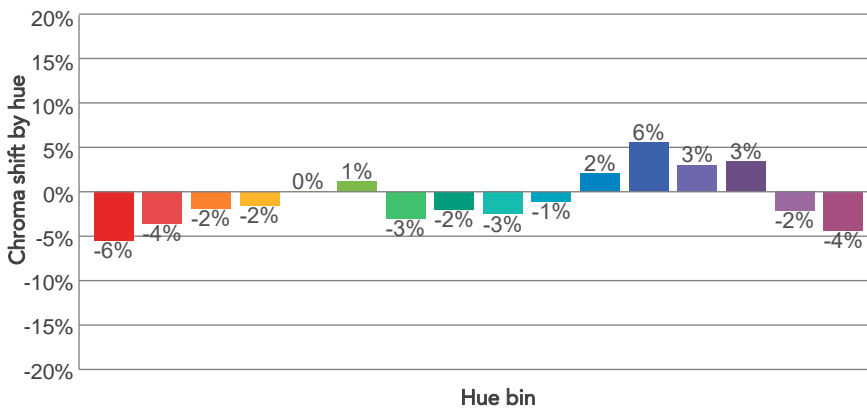
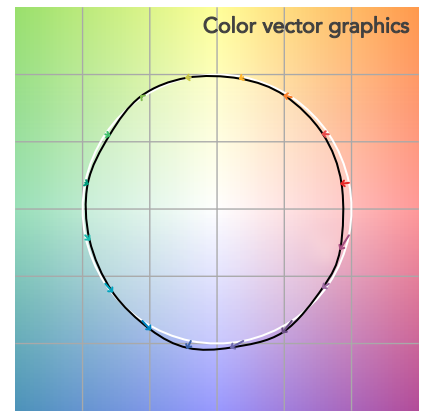
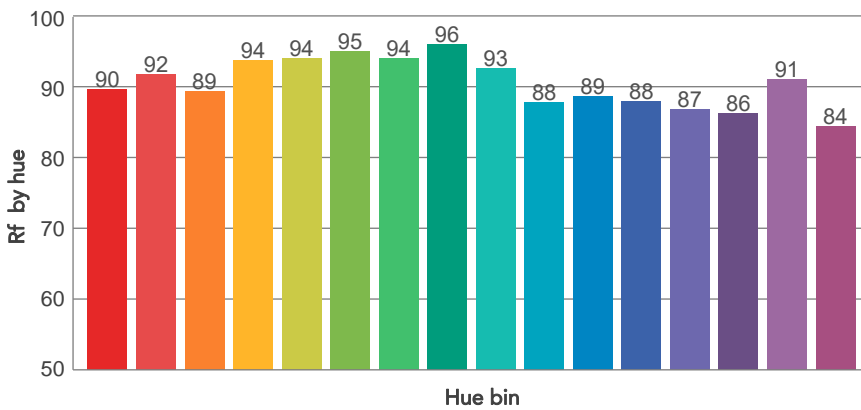
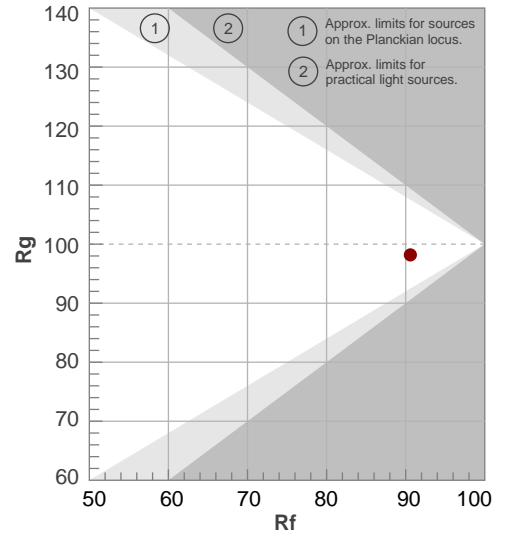



# BEAM DETAILS



Beam angle 50%	Field angle 10%	Cut off angle 2,5%	Intensity ratio in 120° cone	Intensity ratio in 90° cone
10,2°	18,7°	25,9°	100,0%	100,0%

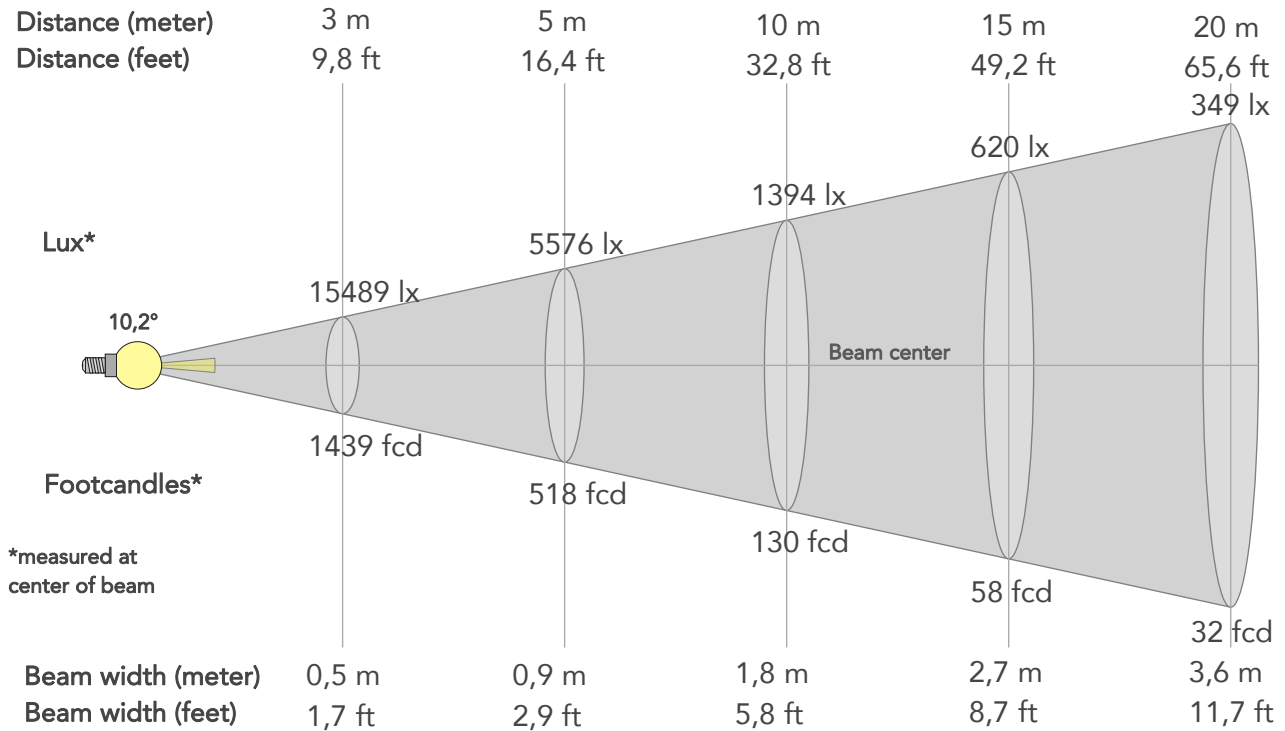

## BEAM INTENSITIES AND WIDTHS

Distance	1m	2m	3m	4m	5m	7,5m	10m	15m	20m	25m	30m	40m	50m
Distance	3,3ft	6,6ft	9,8ft	13,1ft	16,4ft	24,6ft	32,8ft	49,2ft	65,6ft	82ft	98,4ft	131,2ft	164ft
Lux	139405lx	34851lx	15489lx	8713lx	5576lx	2478lx	1394lx	620lx	349lx	223lx	155lx	87lx	56lx
Footcand.	12951fcd	3238fcd	1439fcd	809fcd	518fcd	230fcd	130fcd	58fcd	32fcd	21fcd	14fcd	8fcd	5fcd
Beam wid.	0,2m	0,4m	0,5m	0,7m	0,9m	1,3m	1,8m	2,7m	3,6m	4,4m	5,3m	7,1m	8,9m
Beam wid.	0,6ft	1,2ft	1,7ft	2,3ft	2,9ft	4,4ft	5,8ft	8,7ft	11,7ft	14,6ft	17,5ft	23,3ft	29,1ft

## LINEAR DISTRIBUTION DIAGRAM

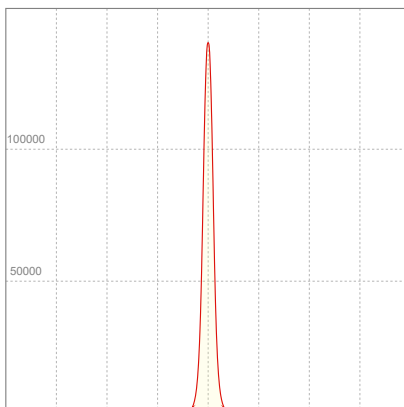

## ELECTRICAL SPECIFICATIONS

Input voltage	Input current	Input power	Effeciency
225V	1,98A	442,3W	12lm/W

## ISO CANDELA DIAGRAM

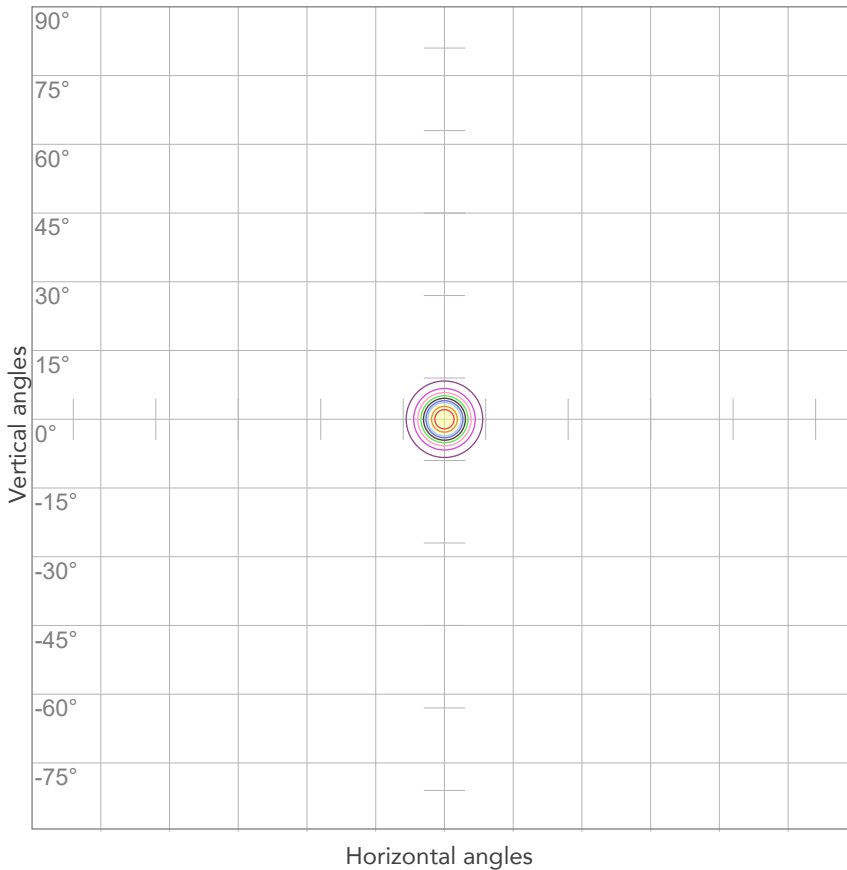

10%	13941 cd
20%	27881 cd
30%	41822 cd
40%	55762 cd
50%	69703 cd
60%	83643 cd
70%	97584 cd
80%	111524 cd

Conditions:

Number of c-planes: 2

Candela at center: 139405 cd

## ISO LUX DIAGRAM

MH: 10,0 m

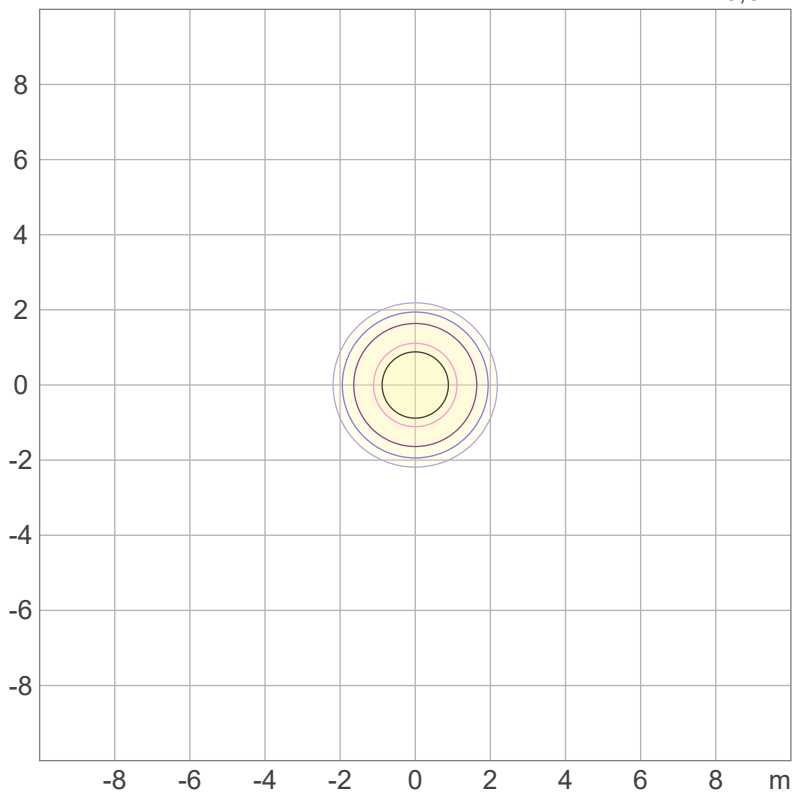

Mounting height: 10 meters (33 feet)

3%	41,8 lx
5%	69,7 lx
10%	139 lx
30%	418 lx
50%	697 lx

Conditions:

Number of c-planes: 2

Lux at center: 1394 lx

*Lux distribution on a surface when lamp is mounted at 10 meters from the surface.*



Total lumen output:

13154 lm

Peak candela output:

17539 cd

Light quality:

CRI: 96,5

Color temperature:

3214 K

**PRODUCT NAME:**  
**ECLFRCTPLIP**

**MEASURAMENT CONDITIONS:**

Beam angle:

Max Zoom

Target:

3200K - HB

Operator:

Salvatore Giglio

Date and time:

03/10/2023 13:13:19

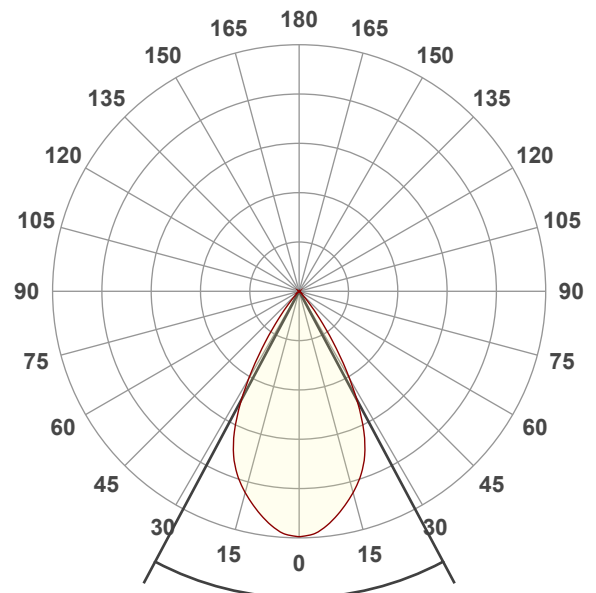

Beam angle 50%: 56,1°

Field angle 10%: 76,9°

Cut off angle 2.5%: 85,5°

Spectra

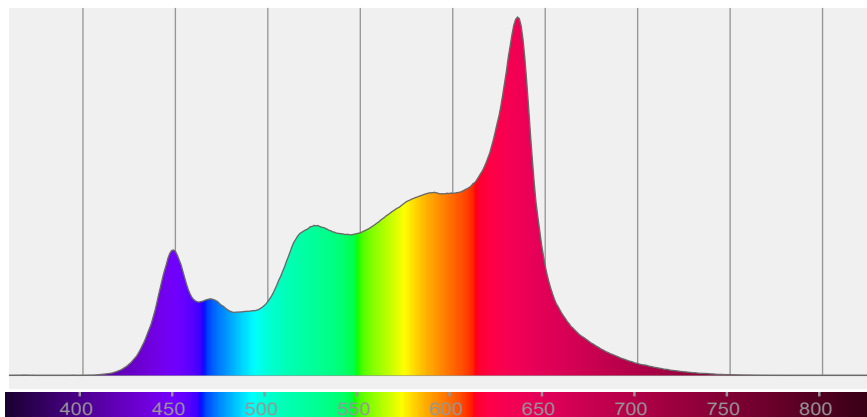

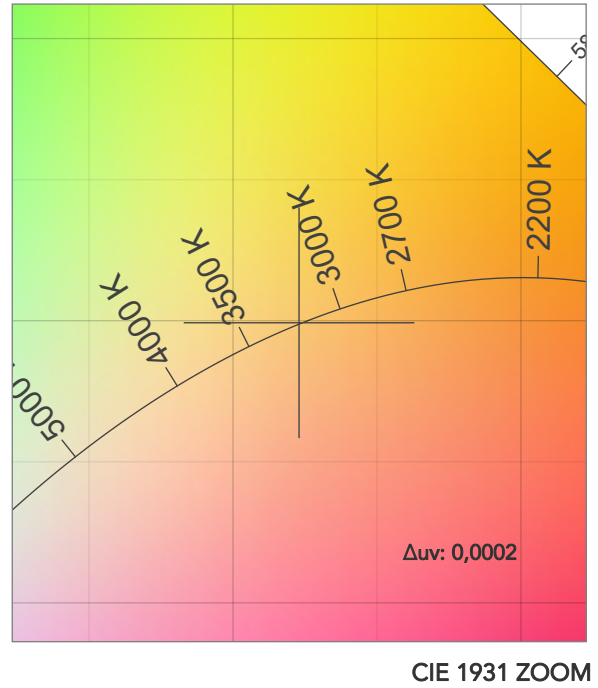
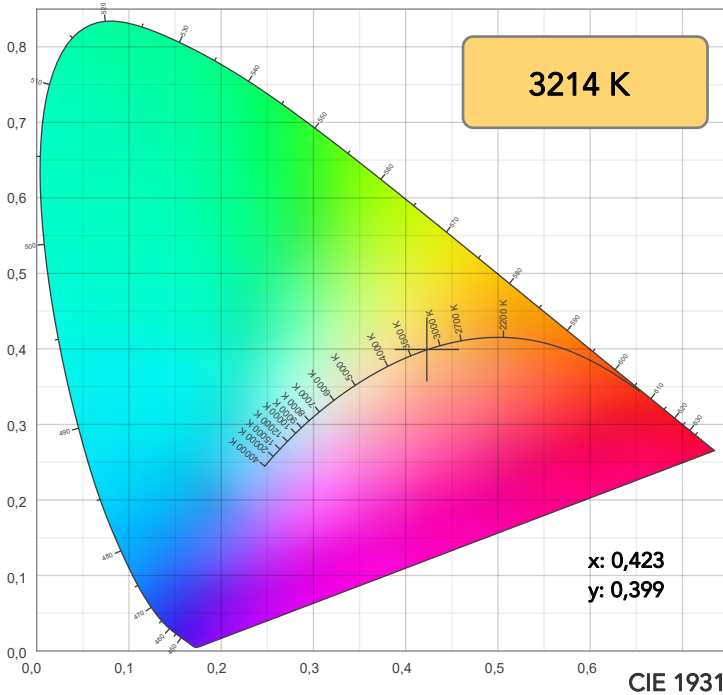

TM30: 93,4

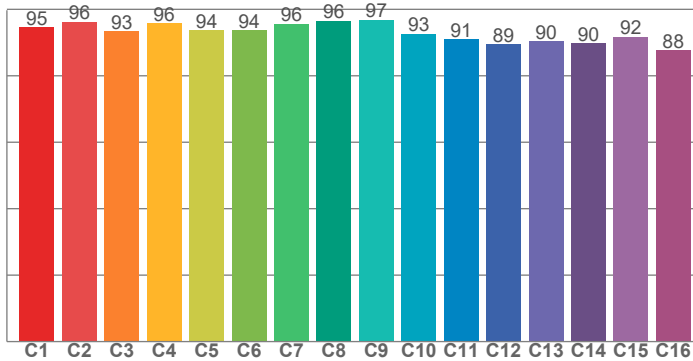

CRI: 96,5 (R1-R8)

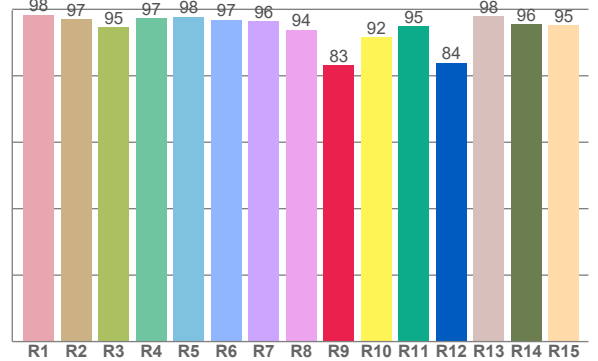

CRI R values, only R1-R8 are used to calculate final CRI value

R1	R2	R3	R4	R5	R6	R7	R8	R9	R10	R11	R12	R13	R14	R15
98,4	97,1	94,5	97,3	97,8	96,9	96,5	93,9	83,2	91,5	94,8	83,9	97,9	95,5	95,2

TM30 C values, 16 binned values out of total of 99 C values

C1	C2	C3	C4	C5	C6	C7	C8	C9	C10	C11	C12	C13	C14	C15	C16
94,6	96,2	93,4	95,7	93,7	93,7	95,7	96,5	96,9	92,6	90,9	89,5	90,4	89,8	91,8	87,7

CQS Q values

Q1	Q2	Q3	Q4	Q5	Q6	Q7	Q8	Q9	Q10	Q11	Q12	Q13	Q14	Q15
92,6	95,3	90,1	92,4	95,8	94,2	92,8	96,1	96,8	94,8	96,4	96,8	97,3	94,5	93,2

CQS: 94,2

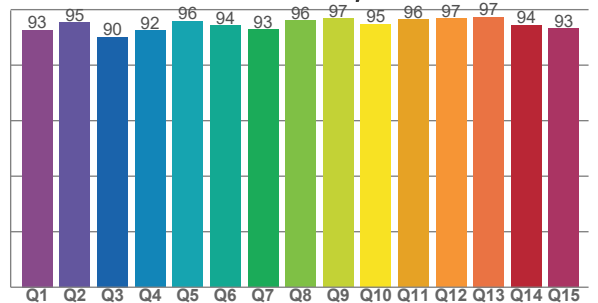

COLOR PARAMETERS

Color temperature	Color rendering index	Red component	Color fidelity	Color gamut	Color quality scale	Television lighting index	Color coordinate cie 1931	Color coordinate cie 1931	Color deviation from black body
CCT	CRI	CRI R9	TM30 Rf	TM30 Rg	CQS	TLCI	x	y	Δuv
3214 K	96,5	83,2	93,4	101,5	94,2	88	0,423	0,399	0,0002

# TM30 DETAILS

**Rf 93,4**  
Fidelity index Rf

**Rg 101,5**  
Gammut index

Hue Bin	R <sub>f</sub>	Graphic shifts (%)	
		Chroma	Hue
1	95	-3%	-1%
2	96	-2%	1%
3	93	-1%	3%
4	96	0%	2%
5	94	0%	3%
6	94	3%	2%
7	96	0%	-1%
8	96	2%	-1%
9	97	0%	1%
10	93	-1%	4%
11	91	2%	6%
12	89	6%	-2%
13	90	3%	-6%
14	90	4%	-7%
15	92	0%	-5%
16	88	0%	-10%

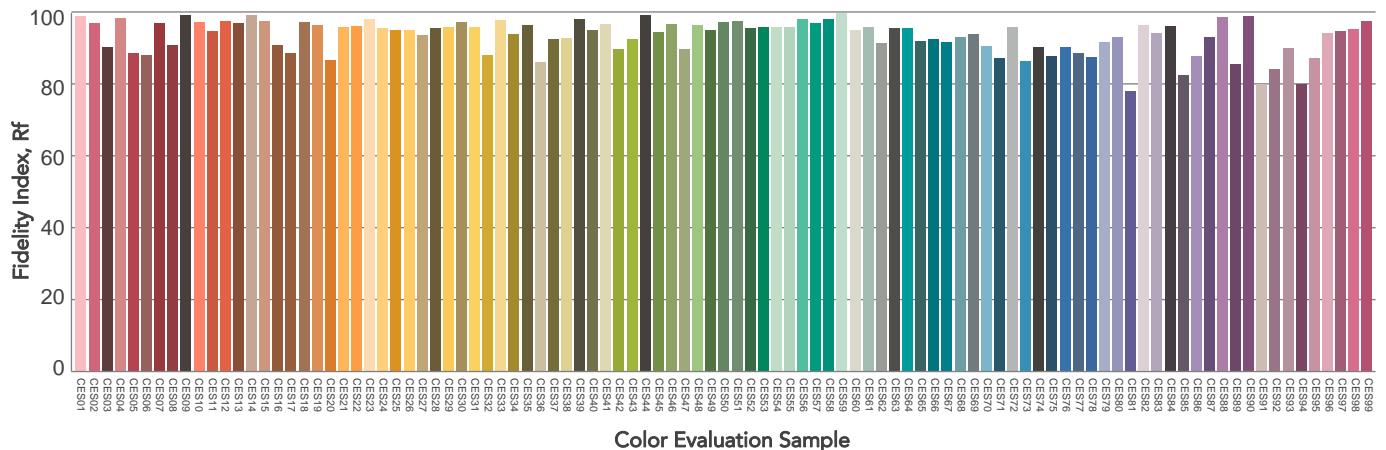
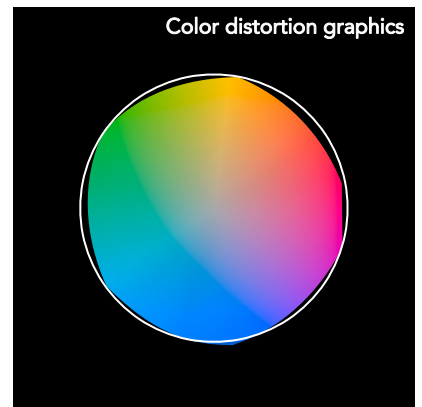
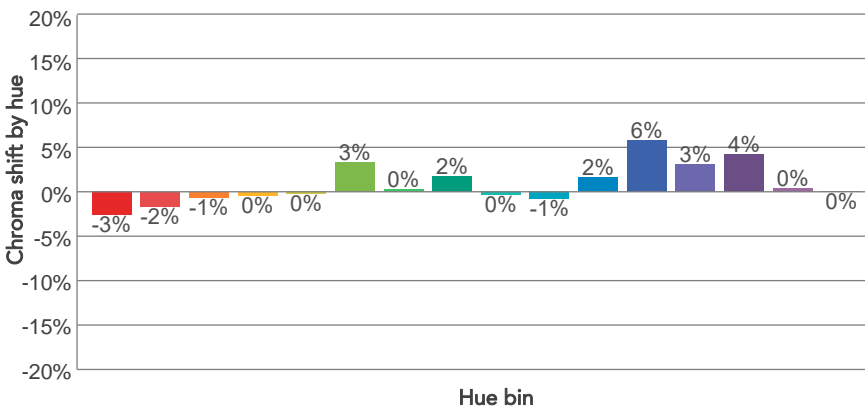
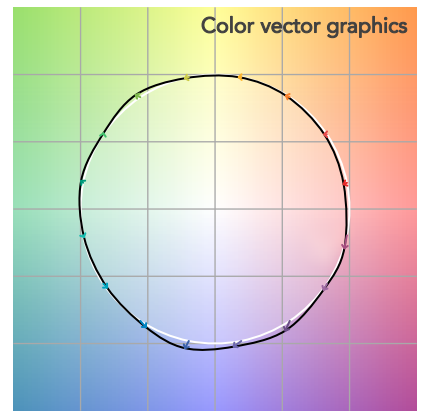
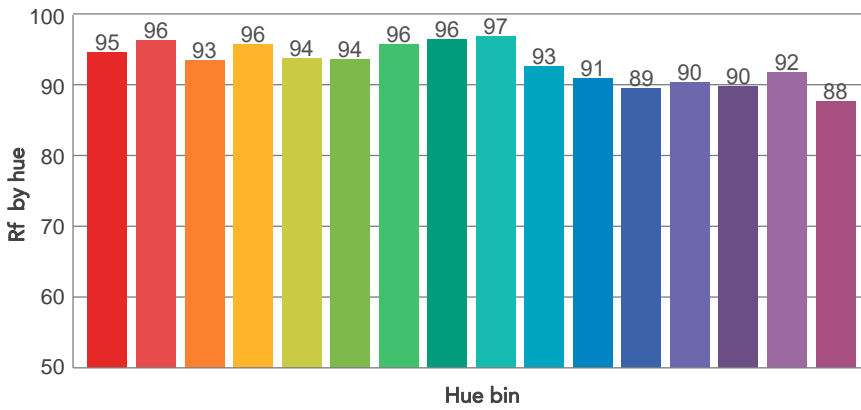
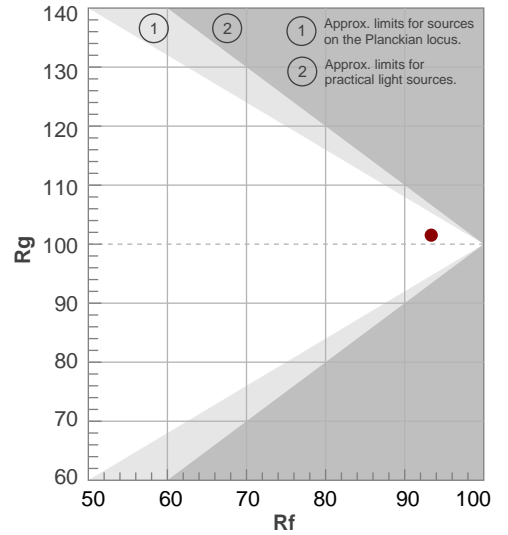

# BEAM DETAILS



Beam angle 50%	Field angle 10%	Cut off angle 2,5%	Intensity ratio in 120° cone	Intensity ratio in 90° cone
56,1°	76,9°	85,5°	100,0%	99,7%

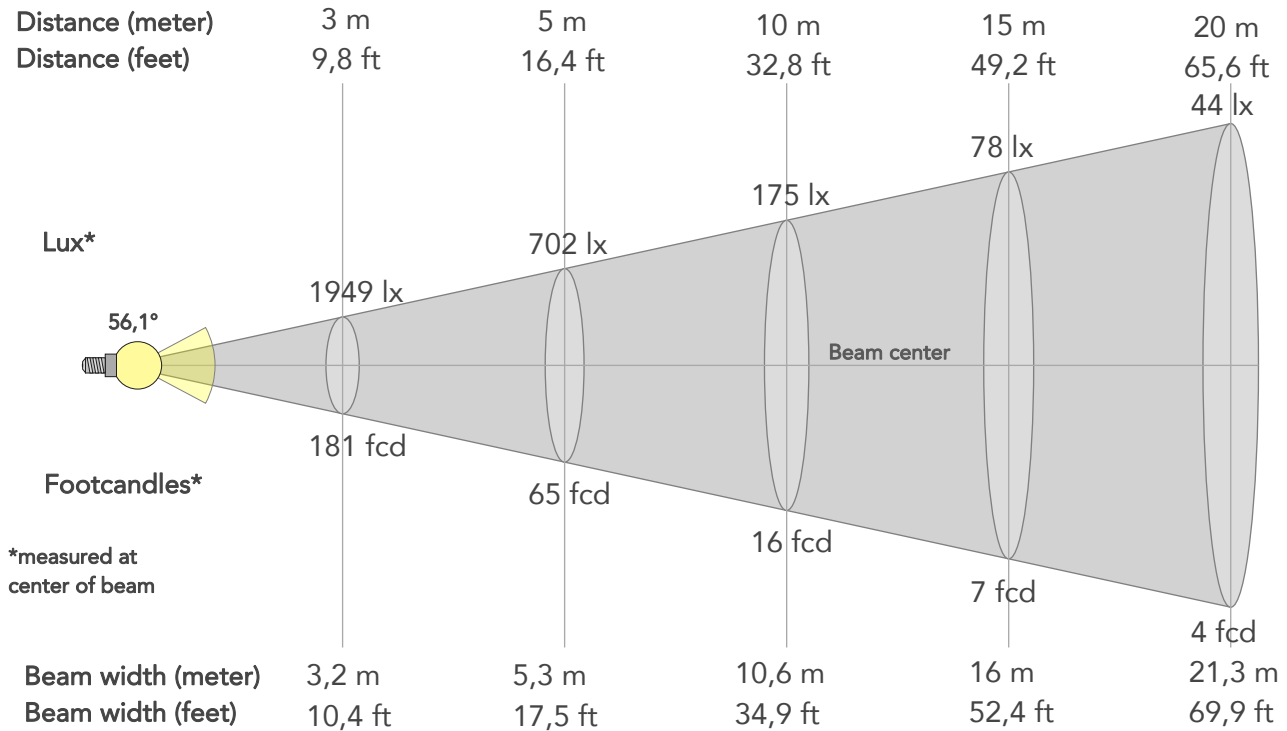

## BEAM INTENSITIES AND WIDTHS

Distance	1m	2m	3m	4m	5m	7,5m	10m	15m	20m	25m	30m	40m	50m
Distance	3,3ft	6,6ft	9,8ft	13,1ft	16,4ft	24,6ft	32,8ft	49,2ft	65,6ft	82ft	98,4ft	131,2ft	164ft
Lux	17539lx	4385lx	1949lx	1096lx	702lx	312lx	175lx	78lx	44lx	28lx	19lx	11lx	7lx
Footcand.	1629fcd	407fcd	181fcd	102fcd	65fcd	29fcd	16fcd	7fcd	4fcd	3fcd	2fcd	1fcd	1fcd
Beam wid.	1,1m	2,1m	3,2m	4,3m	5,3m	8m	10,6m	16m	21,3m	26,6m	31,9m	42,6m	53,2m
Beam wid.	3,5ft	7ft	10,4ft	14ft	17,5ft	26,2ft	34,9ft	52,4ft	69,9ft	87,3ft	104,8ft	139,7ft	174,6ft

## LINEAR DISTRIBUTION DIAGRAM

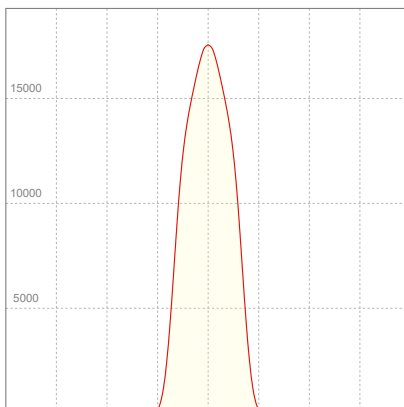

## ELECTRICAL SPECIFICATIONS

Input voltage	Input current	Input power	Effeciency
227V	2,20A	496,1W	27lm/W

## ISO CANDELA DIAGRAM

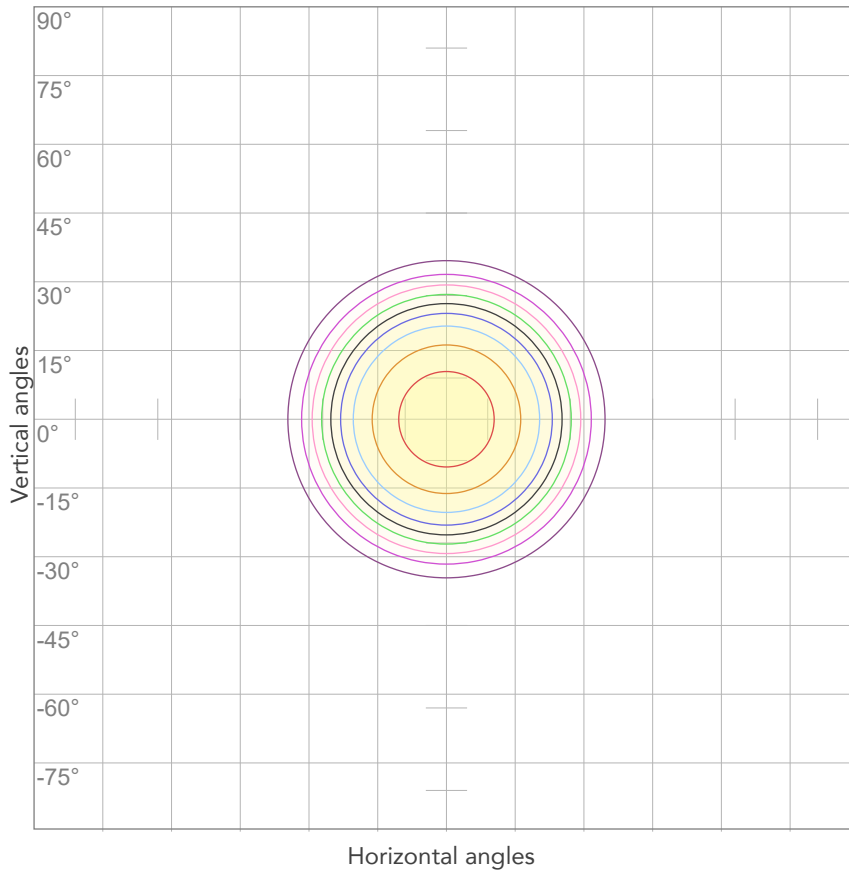

10%	1754 cd
20%	3508 cd
30%	5262 cd
40%	7016 cd
50%	8770 cd
60%	10524 cd
70%	12278 cd
80%	14031 cd

Conditions:

Number of c-planes: 2

Candela at center: 17539 cd

## ISO LUX DIAGRAM

MH: 10,0 m

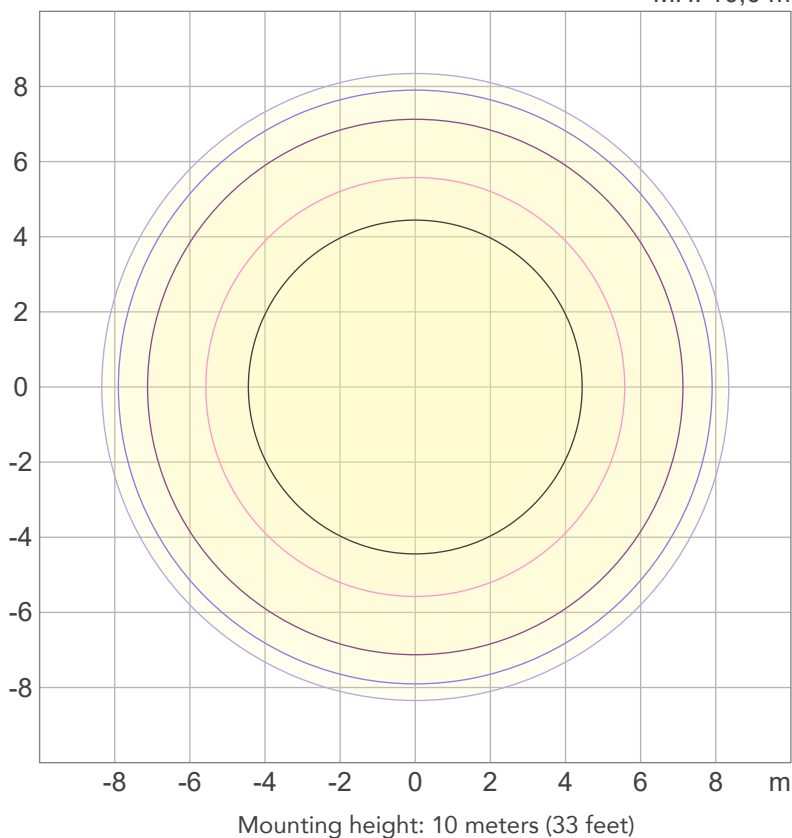

3%	5,26 lx
5%	8,77 lx
10%	17,5 lx
30%	52,6 lx
50%	87,7 lx

Conditions:

Number of c-planes: 2

Lux at center: 175 lx

*Lux distribution on a surface when lamp is mounted at 10 meters from the surface.*



Total lumen output:

10432 lm

Peak candela output:

57020 cd

Light quality:

CRI: 96,1

Color temperature:

3209 K

**PRODUCT NAME:**  
**ECLFRCTPLIP**

**MEASURAMENT CONDITIONS:**

Beam angle:  
Med Zoom

Target:  
3200K - HB

Operator:  
Salvatore Giglio

Date and time:  
03/10/2023 14:30:49

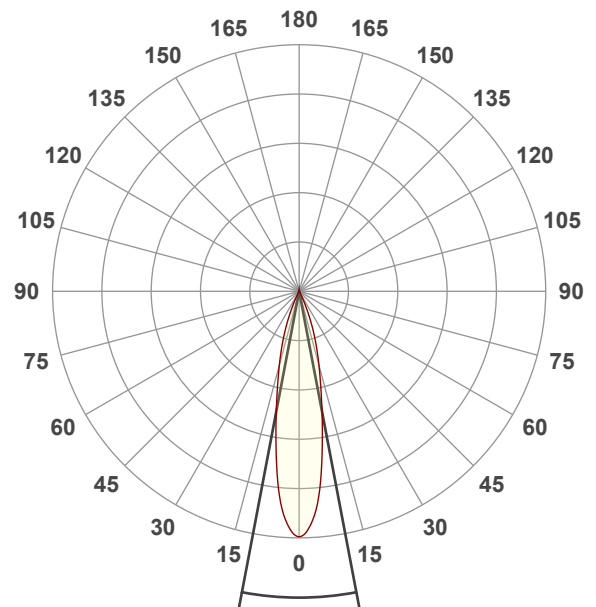

Spectra

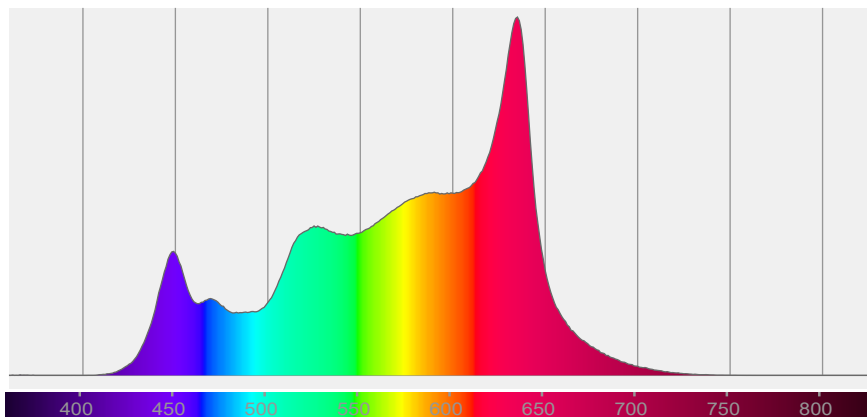



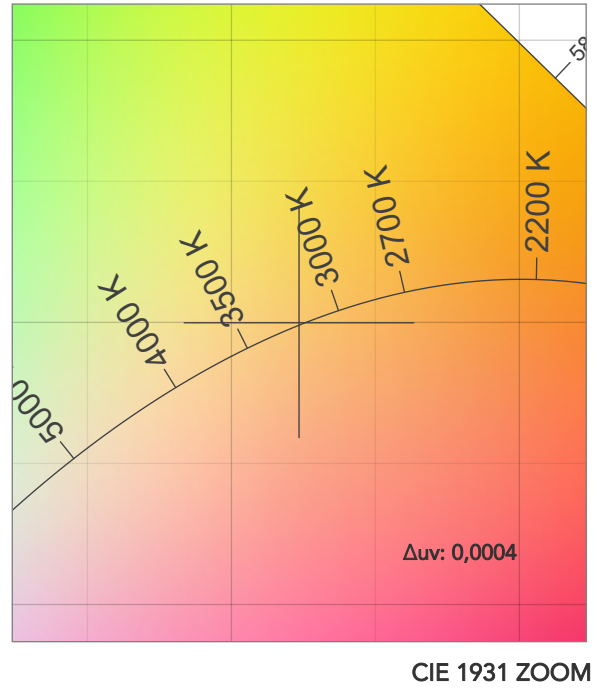
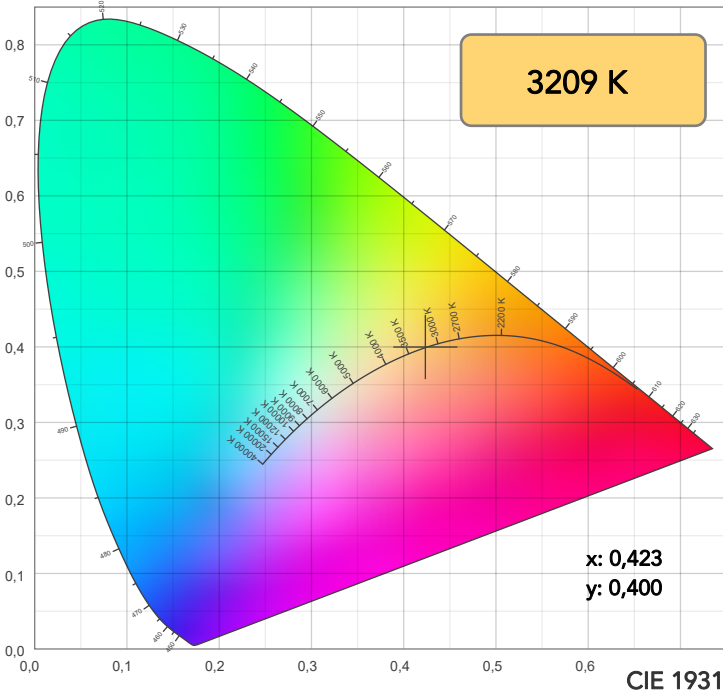

TM30: 93,1

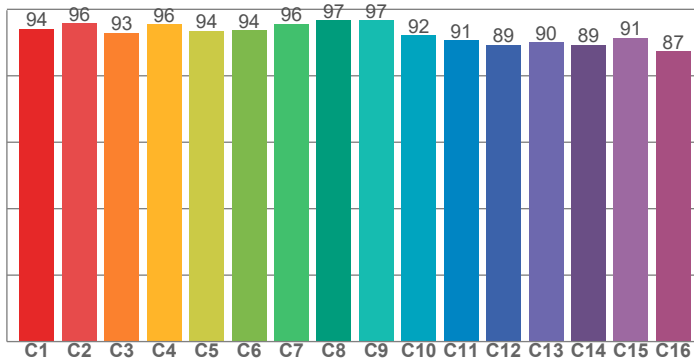

CRI: 96,1 (R1-R8)

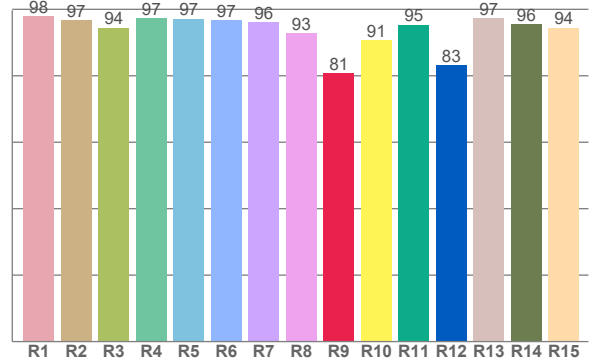

CQS: 93,8

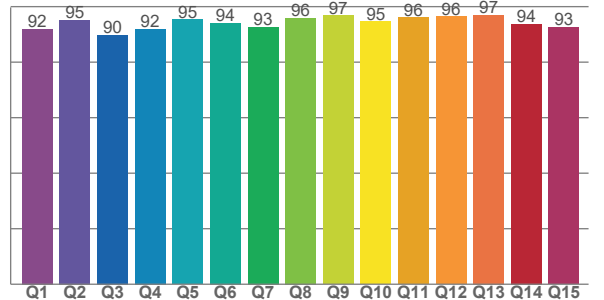

CRI R values, only R1-R8 are used to calculate final CRI value

R1	R2	R3	R4	R5	R6	R7	R8	R9	R10	R11	R12	R13	R14	R15
97,8	96,7	94,5	97,3	97,2	96,6	96,1	92,9	80,7	90,7	95,3	83,3	97,4	95,5	94,5

TM30 C values, 16 binned values out of total of 99 C values

C1	C2	C3	C4	C5	C6	C7	C8	C9	C10	C11	C12	C13	C14	C15	C16
94,1	95,8	92,9	95,5	93,6	93,7	95,6	96,6	96,7	92,2	90,6	89,3	90,1	89,4	91,4	87,3

CQS Q values

Q1	Q2	Q3	Q4	Q5	Q6	Q7	Q8	Q9	Q10	Q11	Q12	Q13	Q14	Q15
92,0	95,2	89,8	92,0	95,3	94,1	92,6	95,9	96,8	94,6	96,0	96,4	96,9	93,8	92,5

COLOR PARAMETERS

Color temperature	Color rendering index	Red component	Color fidelity	Color gamut	Color quality scale	Television lighting index	Color coordinate cie 1931	Color coordinate cie 1931	Color deviation from black body
CCT	CRI	CRI R9	TM30 Rf	TM30 Rg	CQS	TLCI	x	y	Δuv
3209 K	96,1	80,7	93,1	101,3	93,8	87	0,423	0,400	0,0004

# TM30 DETAILS



**Rf 93,1**  
Fidelity index Rf

**Rg 101,3**  
Gammut index

Hue Bin	R <sub>f</sub>	Graphic shifts (%)	
		Chroma	Hue
1	94	-3%	-1%
2	96	-2%	1%
3	93	-1%	3%
4	96	0%	2%
5	94	0%	3%
6	94	3%	2%
7	96	0%	-1%
8	97	2%	-1%
9	97	-1%	1%
10	92	-1%	4%
11	91	2%	6%
12	89	6%	-2%
13	90	3%	-6%
14	89	4%	-7%
15	91	0%	-5%
16	87	0%	-10%

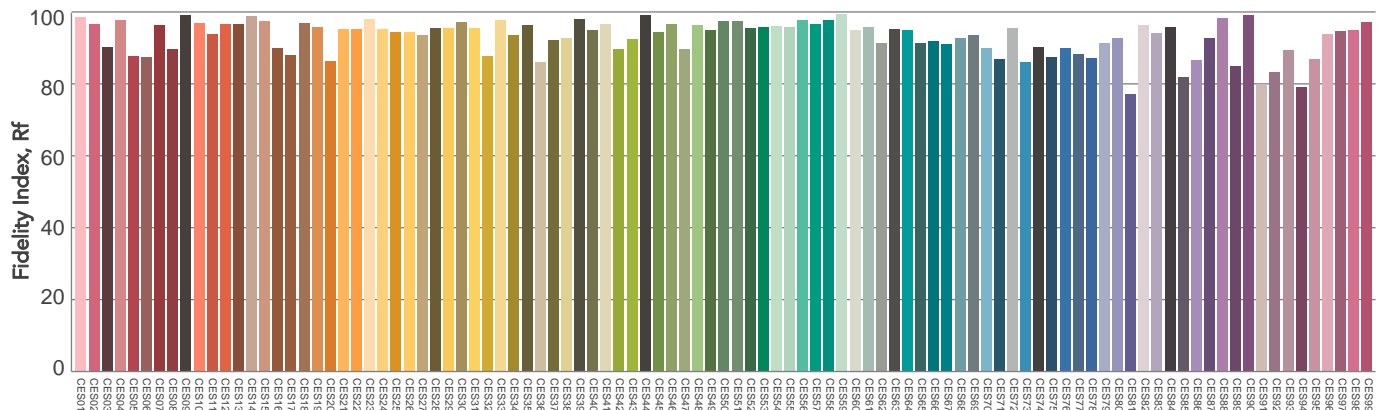
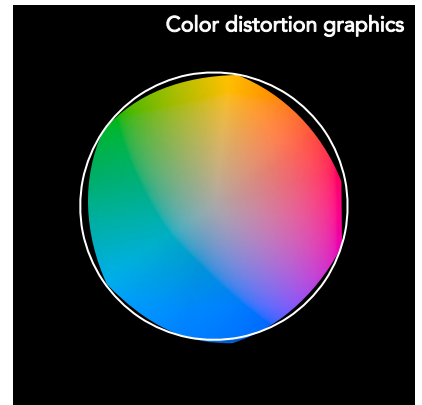
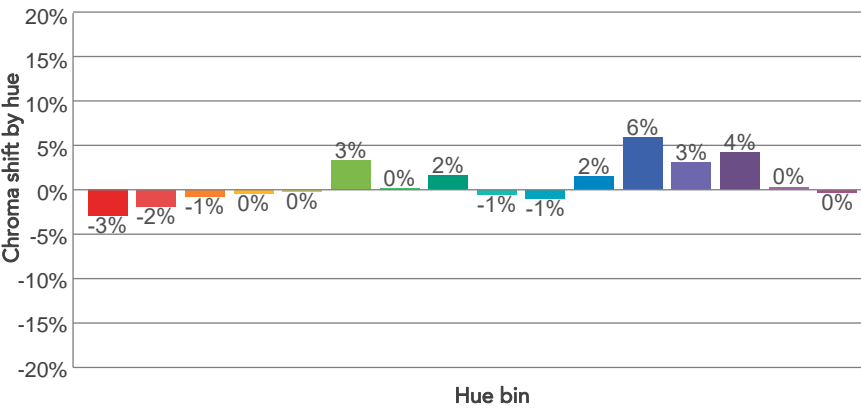
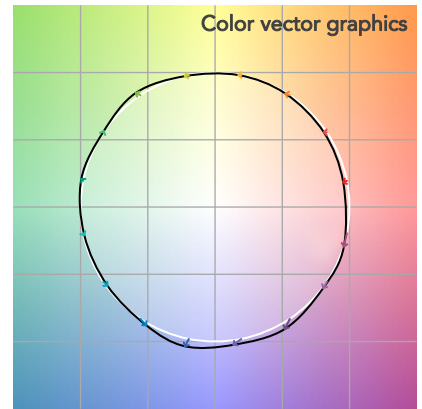
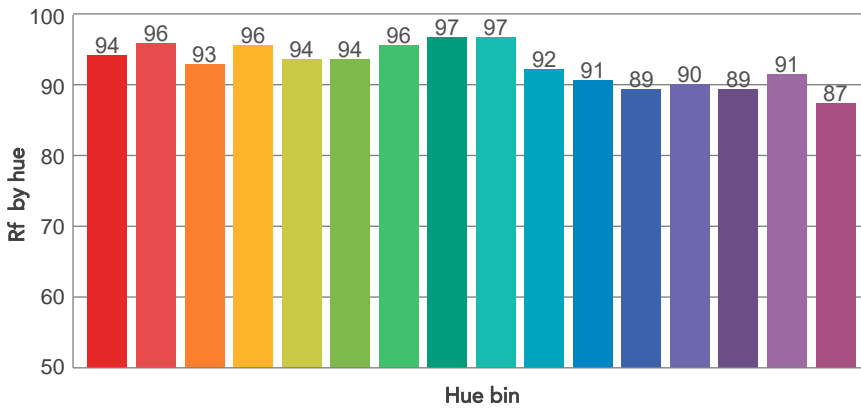
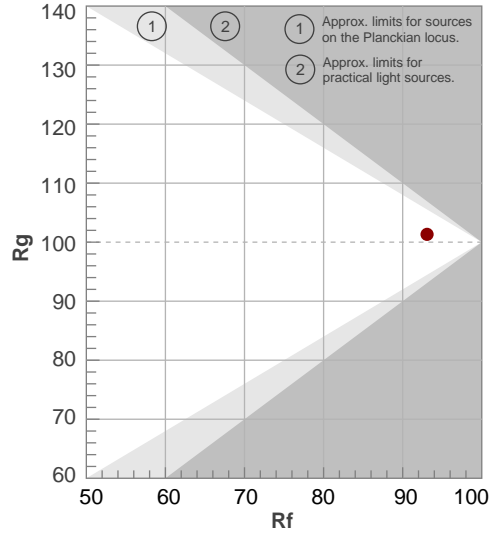

Color Evaluation Sample

# BEAM DETAILS



Beam angle 50%	Field angle 10%	Cut off angle 2,5%	Intensity ratio in 120° cone	Intensity ratio in 90° cone
21,5°	44,6°	53°	100,0%	100,0%

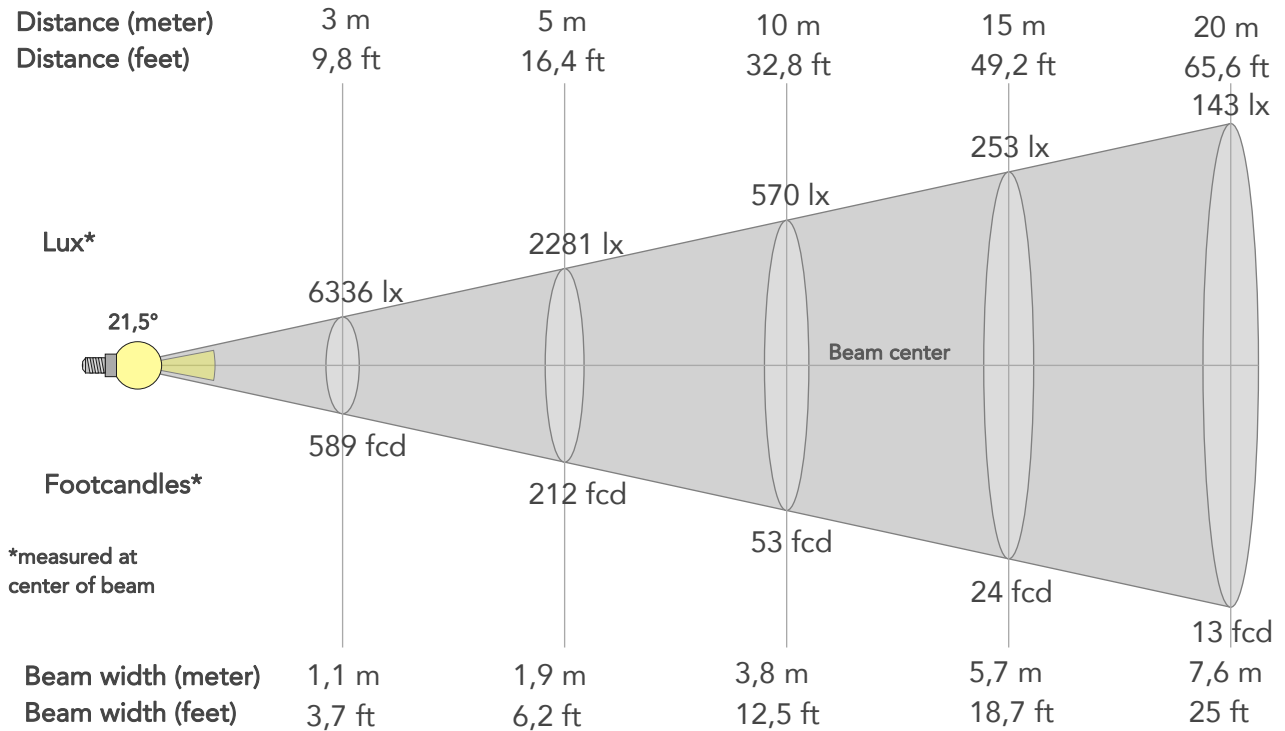

## BEAM INTENSITIES AND WIDTHS

Distance	1m	2m	3m	4m	5m	7,5m	10m	15m	20m	25m	30m	40m	50m
Distance	3,3ft	6,6ft	9,8ft	13,1ft	16,4ft	24,6ft	32,8ft	49,2ft	65,6ft	82ft	98,4ft	131,2ft	164ft
Lux	57020lx	14255lx	6336lx	3564lx	2281lx	1014lx	570lx	253lx	143lx	91lx	63lx	36lx	23lx
Footcand.	5297fcd	1324fcd	589fcd	331fcd	212fcd	94fcd	53fcd	24fcd	13fcd	8fcd	6fcd	3fcd	2fcd
Beam wid.	0,4m	0,8m	1,1m	1,5m	1,9m	2,9m	3,8m	5,7m	7,6m	9,5m	11,4m	15,2m	19m
Beam wid.	1,3ft	2,5ft	3,7ft	5ft	6,2ft	9,4ft	12,5ft	18,7ft	25ft	31,2ft	37,4ft	49,9ft	62,4ft

## LINEAR DISTRIBUTION DIAGRAM

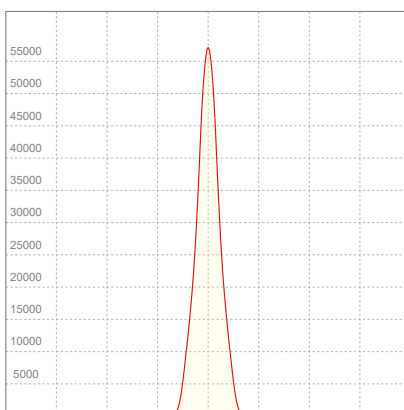

## ELECTRICAL SPECIFICATIONS

Input voltage	Input current	Input power	Effeciency
225V	2,19A	489,4W	21lm/W

## ISO CANDELA DIAGRAM

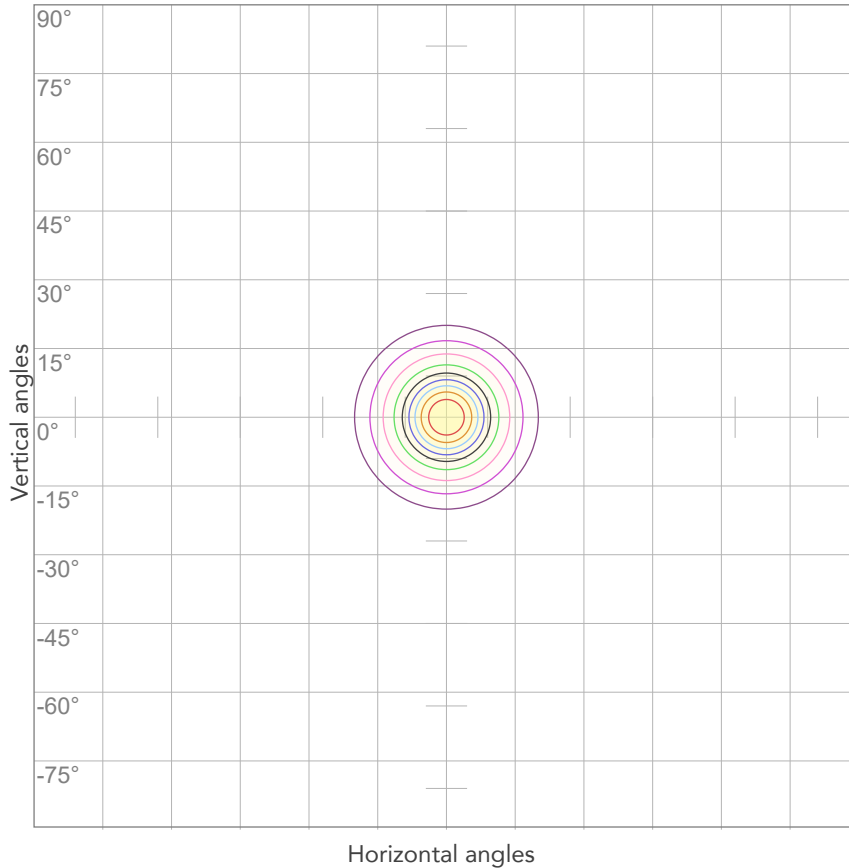

10%	5702 cd
20%	11404 cd
30%	17106 cd
40%	22808 cd
50%	28510 cd
60%	34212 cd
70%	39914 cd
80%	45616 cd

Conditions:

Number of c-planes: 2

Candela at center: 57020 cd

## ISO LUX DIAGRAM

MH: 10,0 m

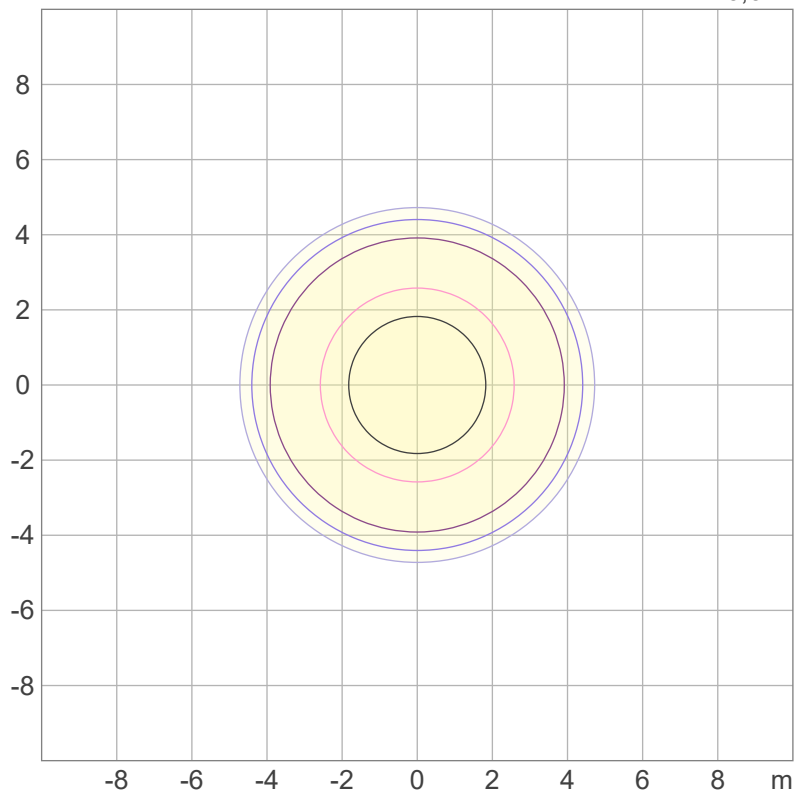

3%	17,1 lx
5%	28,5 lx
10%	57,0 lx
30%	171 lx
50%	285 lx

Conditions:

Number of c-planes: 2

Lux at center: 570 lx

*Lux distribution on a surface when lamp is mounted at 10 meters from the surface.*



Total lumen output:

5748 lm

Peak candela output:

148943 cd

Light quality:

CRI: 96,3

Color temperature:

3234 K

**PRODUCT NAME:**  
**ECLFRCTPLIP**

**MEASURAMENT CONDITIONS:**

Beam angle:

Min Zoom

Target:

3200K - HB

Operator:

Salvatore Giglio

Date and time:

03/10/2023 14:11:43

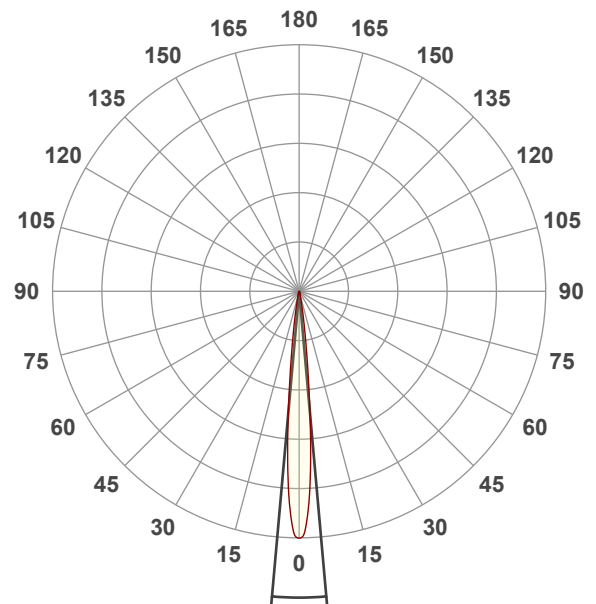

Spectra

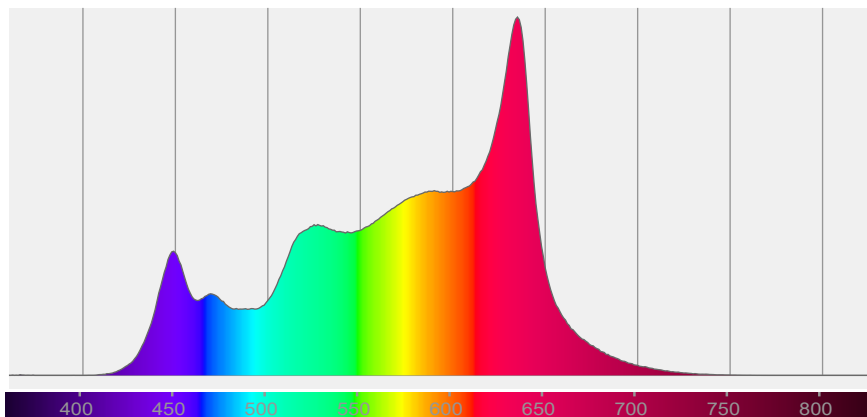

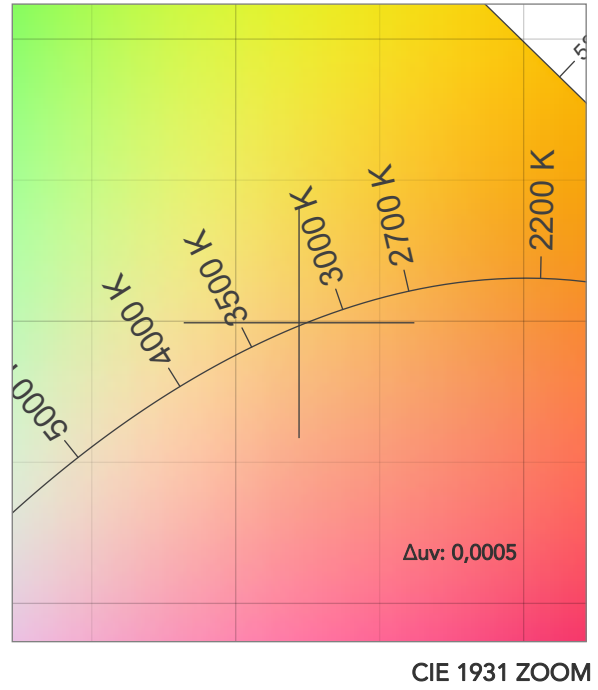
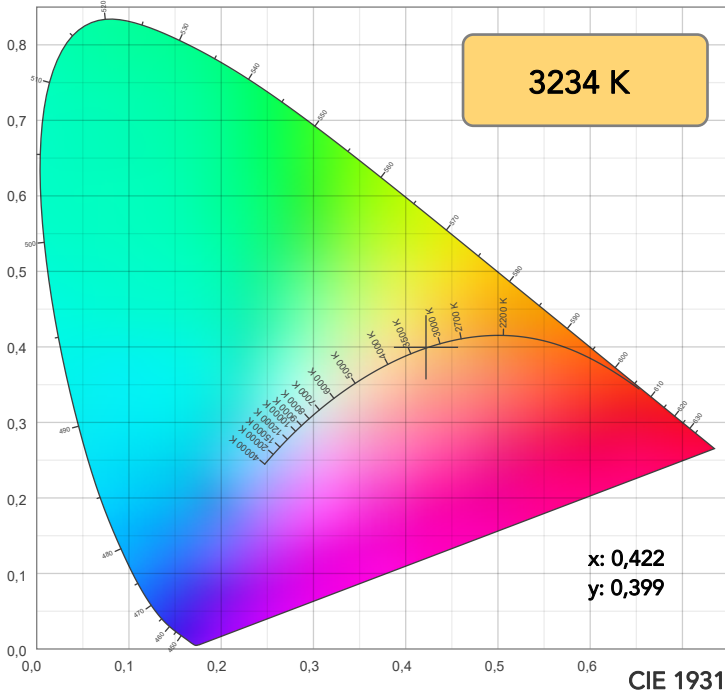

TM30: 93,2

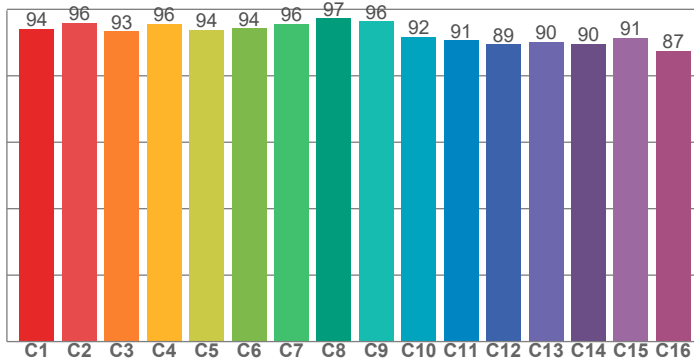

CRI: 96,3 (R1-R8)

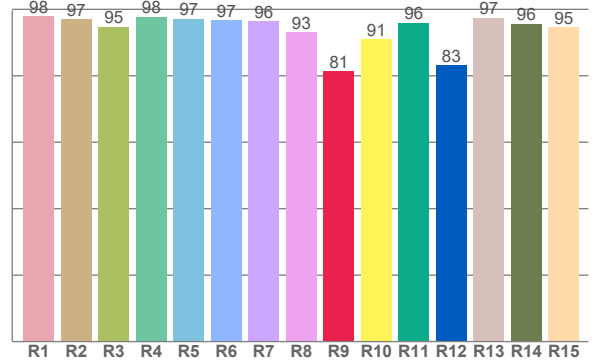

CRI R values, only R1-R8 are used to calculate final CRI value

R1	R2	R3	R4	R5	R6	R7	R8	R9	R10	R11	R12	R13	R14	R15
97,9	96,9	94,7	97,7	97,2	96,7	96,3	93,1	81,3	91,1	95,9	83,2	97,5	95,7	94,6

TM30 C values, 16 binned values out of total of 99 C values

C1	C2	C3	C4	C5	C6	C7	C8	C9	C10	C11	C12	C13	C14	C15	C16
94,2	95,9	93,4	95,7	93,8	94,3	95,6	97,2	96,4	91,7	90,6	89,4	90,1	89,5	91,5	87,5

CQS Q values

Q1	Q2	Q3	Q4	Q5	Q6	Q7	Q8	Q9	Q10	Q11	Q12	Q13	Q14	Q15
92,2	95,2	90,2	91,9	95,4	94,9	93,3	96,1	96,9	94,9	96,2	96,6	97,0	94,0	92,8

CQS: 94,1

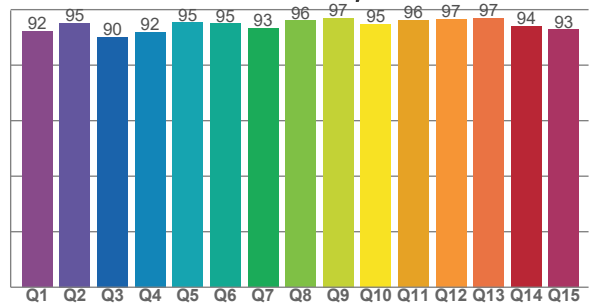

COLOR PARAMETERS

Color temperature	Color rendering index	Red component	Color fidelity	Color gamut	Color quality scale	Television lighting index	Color coordinate cie 1931	Color coordinate cie 1931	Color deviation from black body
CCT	CRI	CRI R9	TM30 Rf	TM30 Rg	CQS	TLCI	x	y	Δuv
3234 K	96,3	81,3	93,2	101,0	94,1	88	0,422	0,399	0,0005

# TM30 DETAILS

**Rf 93,2**  
Fidelity index Rf

**Rg 101,0**  
Gammut index

Hue Bin	R <sub>f</sub>	Graphic shifts (%)	
		Chroma	Hue
1	94	-3%	0%
2	96	-2%	1%
3	93	-1%	3%
4	96	-1%	2%
5	94	-1%	3%
6	94	3%	2%
7	96	0%	0%
8	97	1%	-1%
9	96	-1%	2%
10	92	-1%	5%
11	91	2%	6%
12	89	6%	-2%
13	90	3%	-7%
14	90	4%	-7%
15	91	0%	-5%
16	87	0%	-10%

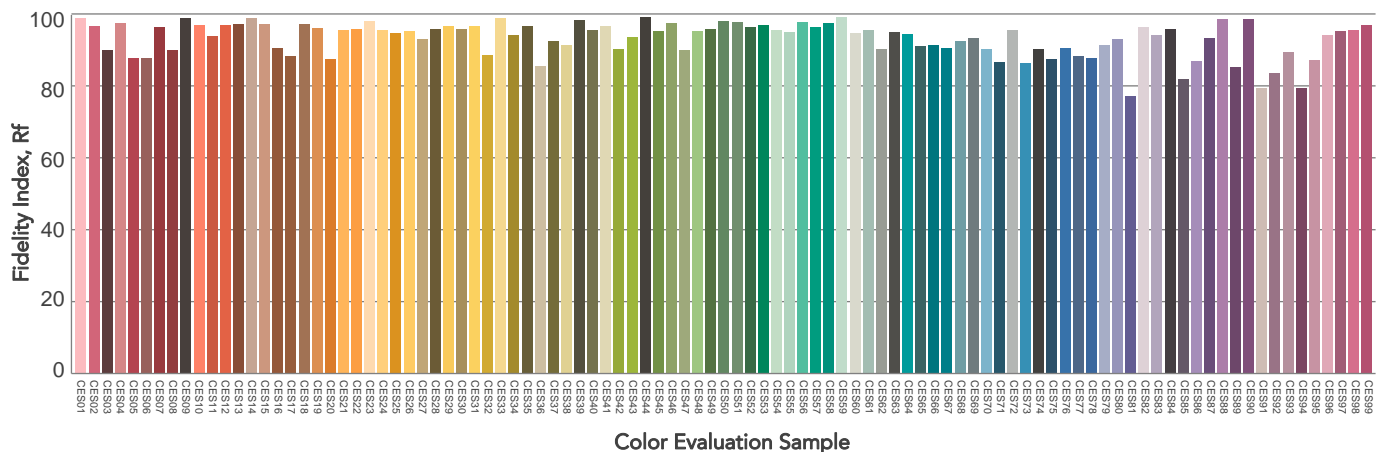
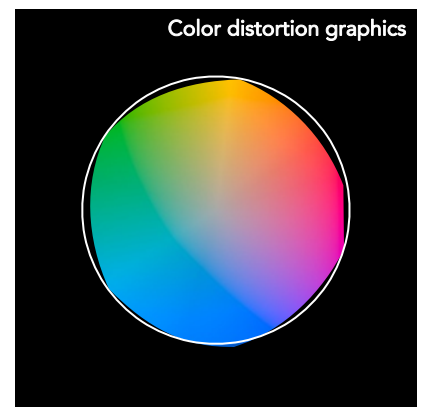
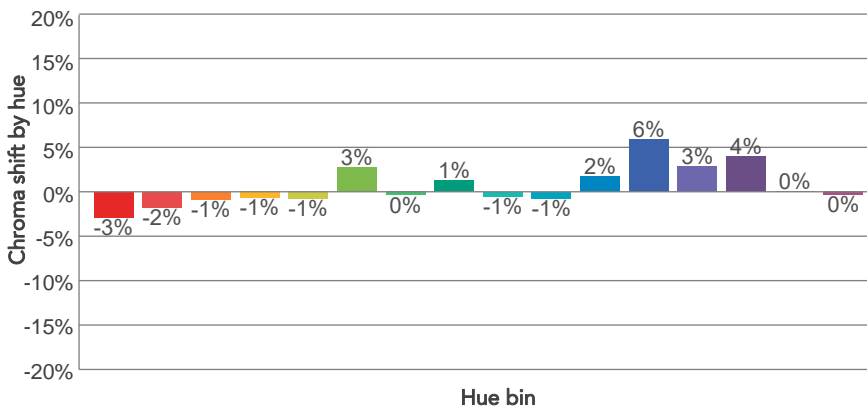
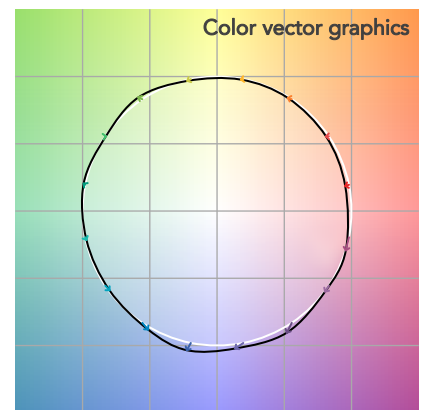
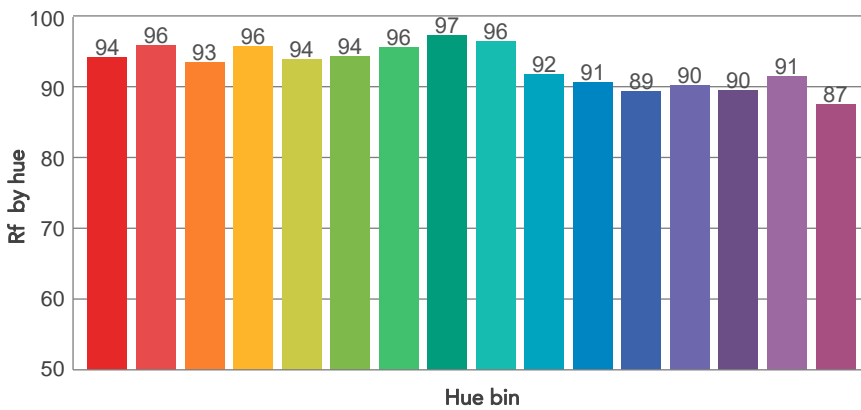
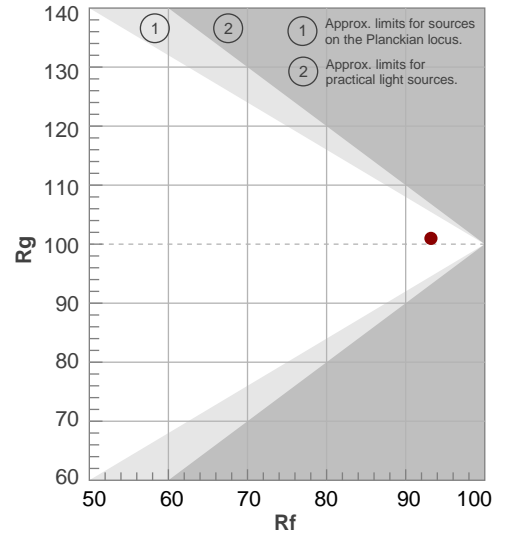

# BEAM DETAILS



Beam angle 50%	Field angle 10%	Cut off angle 2,5%	Intensity ratio in 120° cone	Intensity ratio in 90° cone
10,2°	18,8°	26°	100,0%	100,0%

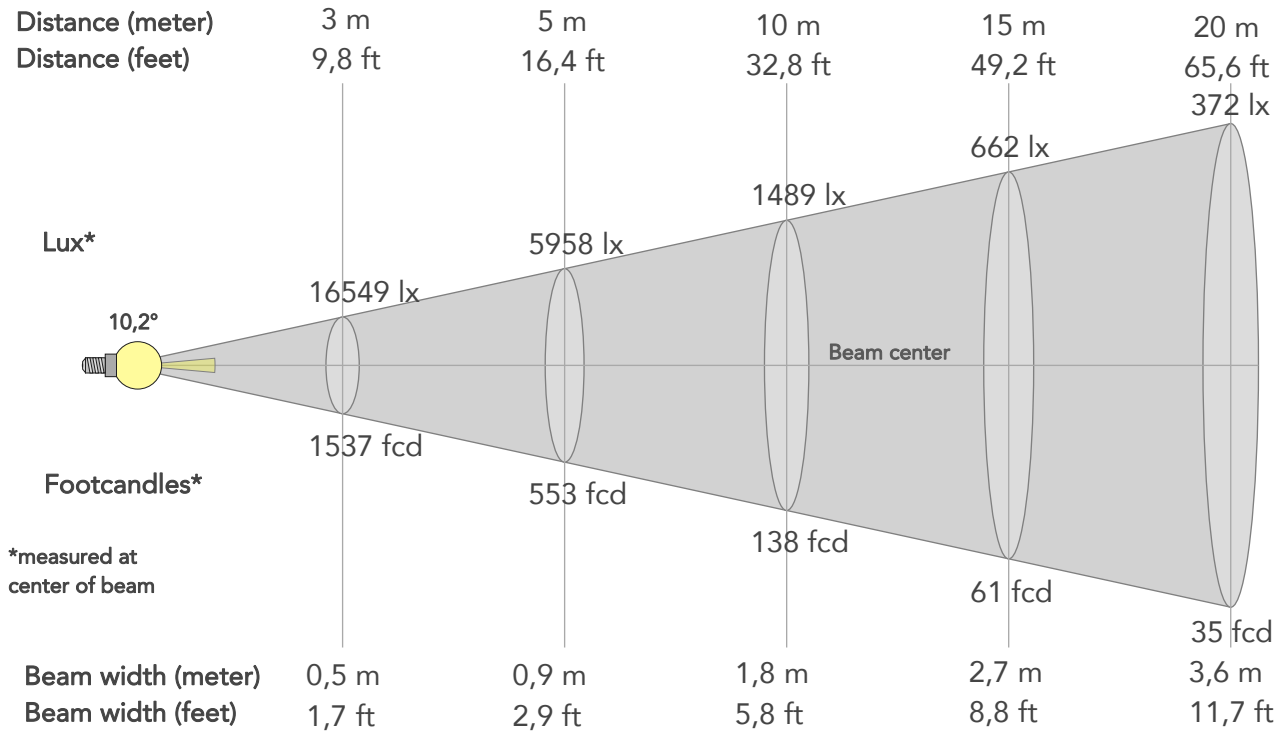

## BEAM INTENSITIES AND WIDTHS

Distance	1m	2m	3m	4m	5m	7,5m	10m	15m	20m	25m	30m	40m	50m
Distance	3,3ft	6,6ft	9,8ft	13,1ft	16,4ft	24,6ft	32,8ft	49,2ft	65,6ft	82ft	98,4ft	131,2ft	164ft
Lux	148943lx	37236lx	16549lx	9309lx	5958lx	2648lx	1489lx	662lx	372lx	238lx	165lx	93lx	60lx
Footcand.	13837fcd	3459fcd	1537fcd	865fcd	553fcd	246fcd	138fcd	61fcd	35fcd	22fcd	15fcd	9fcd	6fcd
Beam wid.	0,2m	0,4m	0,5m	0,7m	0,9m	1,3m	1,8m	2,7m	3,6m	4,5m	5,3m	7,1m	8,9m
Beam wid.	0,6ft	1,2ft	1,7ft	2,3ft	2,9ft	4,4ft	5,8ft	8,8ft	11,7ft	14,6ft	17,5ft	23,4ft	29,2ft

## LINEAR DISTRIBUTION DIAGRAM

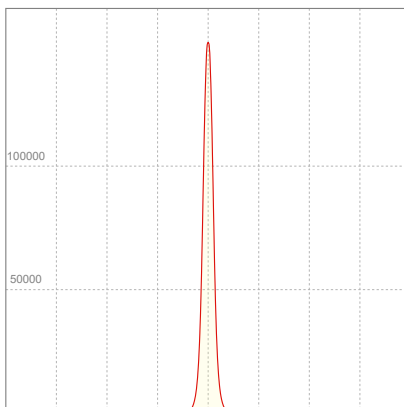

## ELECTRICAL SPECIFICATIONS

Input voltage	Input current	Input power	Effeciency
226V	2,20A	494,9W	12lm/W



## ISO CANDELA DIAGRAM

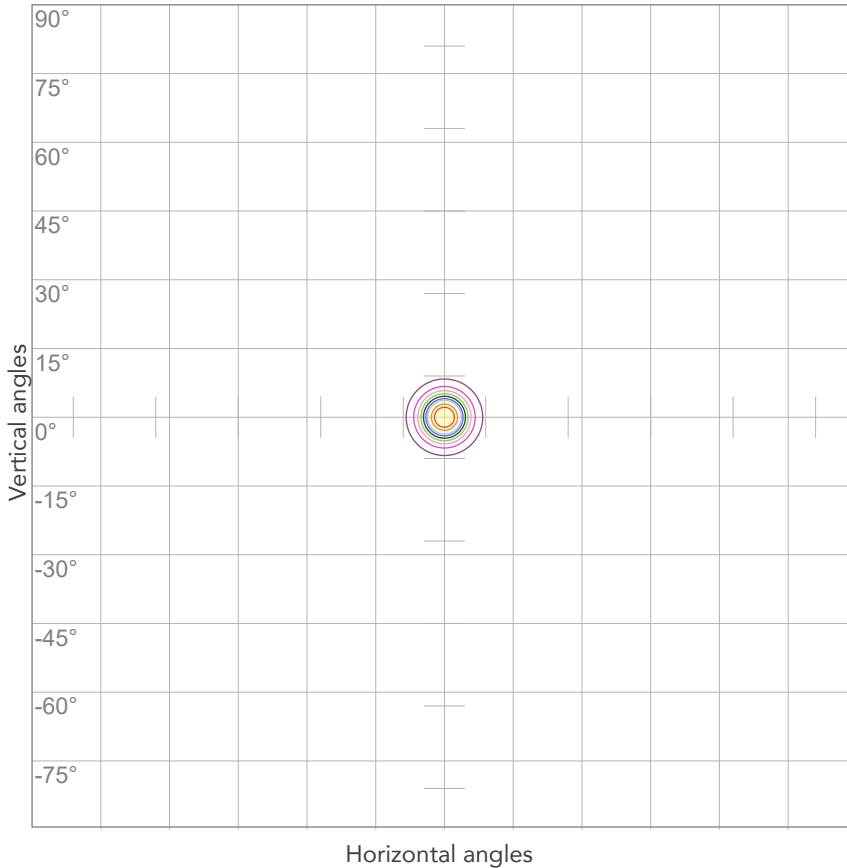

10%	14894 cd
20%	29789 cd
30%	44683 cd
40%	59577 cd
50%	74471 cd
60%	89366 cd
70%	104260 cd
80%	119154 cd

Conditions:

Number of c-planes: 2

Candela at center: 148943 cd

## ISO LUX DIAGRAM

MH: 10,0 m

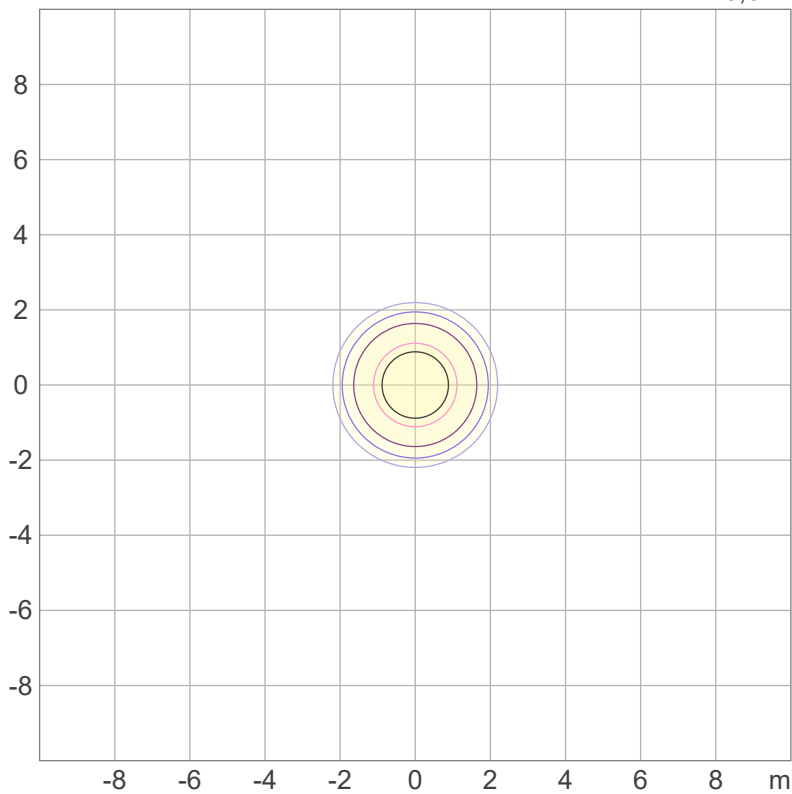

Mounting height: 10 meters (33 feet)

3%	44,7 lx
5%	74,5 lx
10%	149 lx
30%	447 lx
50%	745 lx

Conditions:

Number of c-planes: 2

Lux at center: 1489 lx

*Lux distribution on a surface when lamp is mounted at 10 meters from the surface.*



Total lumen output:

13977 lm

Peak candela output:

18478 cd

Light quality:

CRI: 96,4

Color temperature:

4071 K

**PRODUCT NAME:**  
**ECLFRCTPLIP**

**MEASURAMENT CONDITIONS:**

Beam angle:  
Max Zoom

Target:  
4000K - HB

Operator:  
Salvatore Giglio

Date and time:  
03/10/2023 13:11:33

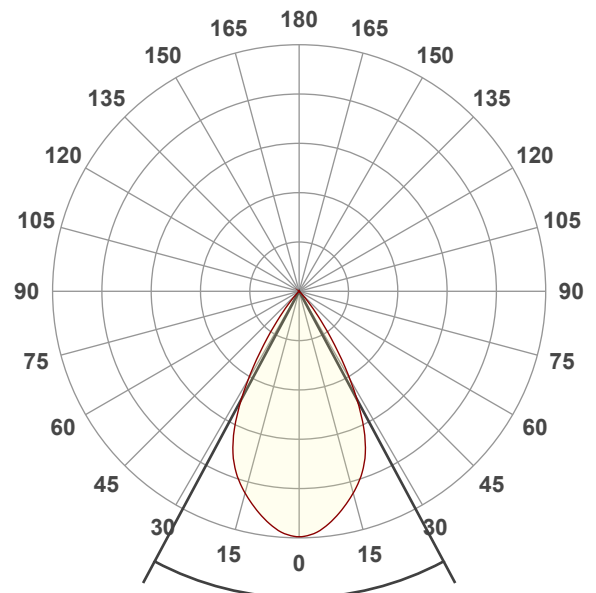

Beam angle 50%: 56,3°

Field angle 10%: 77°

Cut off angle 2.5%: 86,1°

Spectra

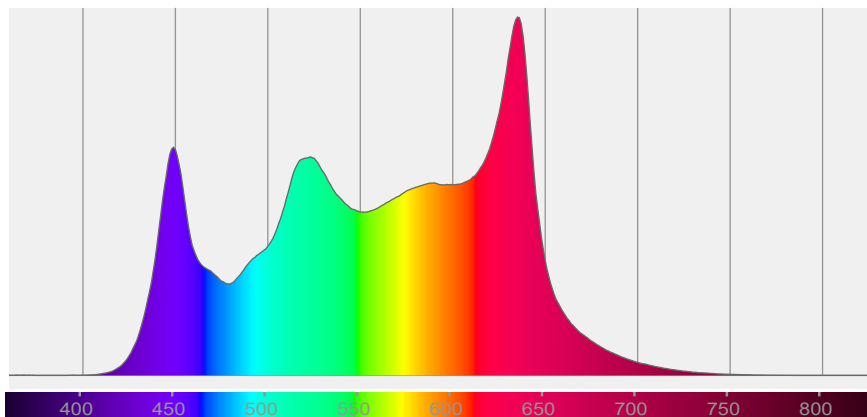

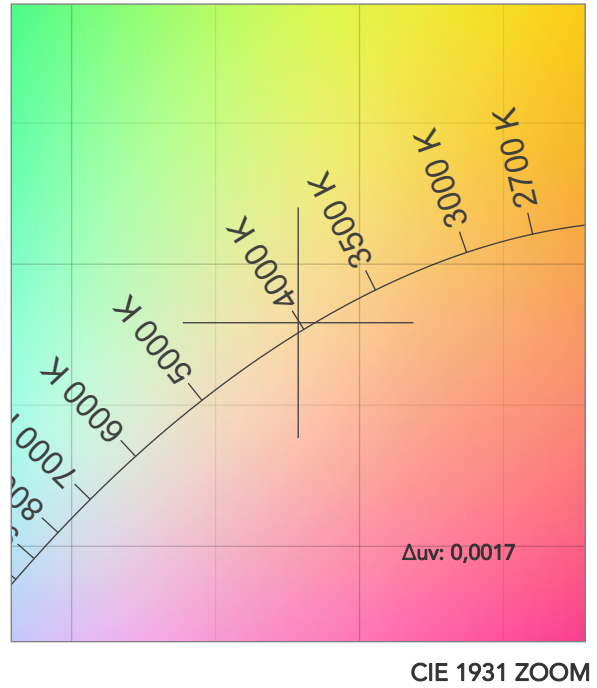
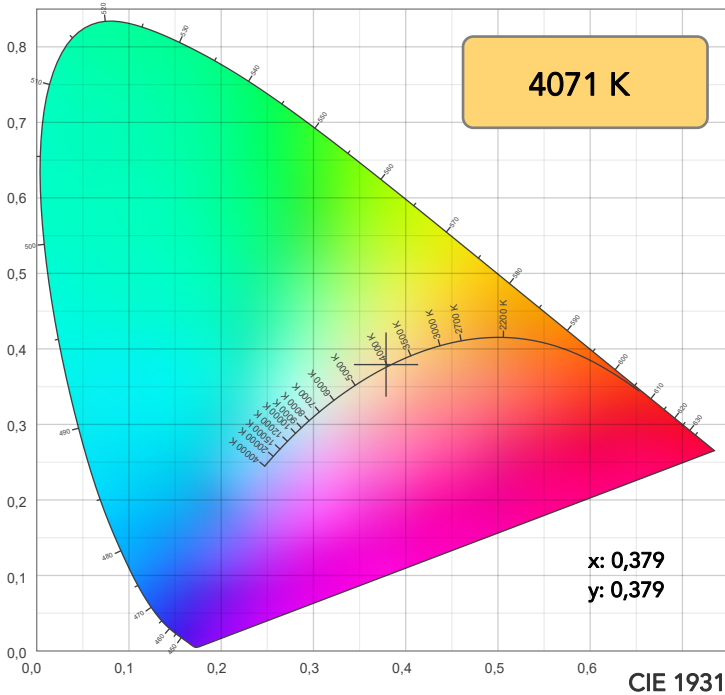

TM30: 94,2

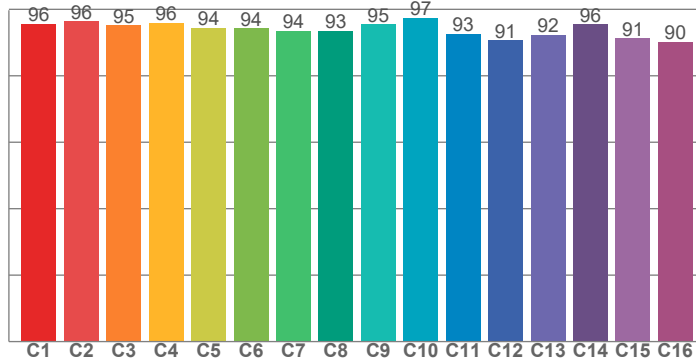

CRI: 96,4 (R1-R8)

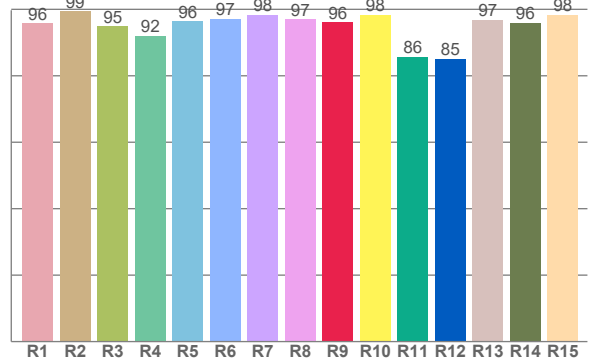

CRI R values, only R1-R8 are used to calculate final CRI value

R1	R2	R3	R4	R5	R6	R7	R8	R9	R10	R11	R12	R13	R14	R15
95,7	99,5	94,8	92,0	96,5	97,1	98,4	97,0	96,1	98,4	85,8	85,2	96,8	96,0	98,3

TM30 C values, 16 binned values out of total of 99 C values

C1	C2	C3	C4	C5	C6	C7	C8	C9	C10	C11	C12	C13	C14	C15	C16
95,7	96,4	95,1	95,9	94,4	94,2	93,5	93,5	95,5	97,5	92,6	90,6	92,3	95,5	91,3	90,2

CQS Q values

Q1	Q2	Q3	Q4	Q5	Q6	Q7	Q8	Q9	Q10	Q11	Q12	Q13	Q14	Q15
96,6	97,5	95,0	98,9	95,8	94,7	98,0	97,7	98,1	98,5	95,0	95,0	95,8	98,3	98,1

CQS: 96,5

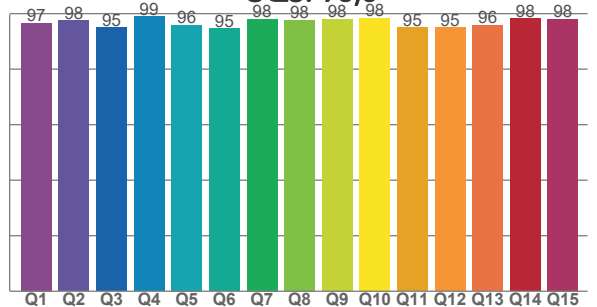

COLOR PARAMETERS

Color temperature	Color rendering index	Red component	Color fidelity	Color gamut	Color quality scale	Television lighting index	Color coordinate cie 1931	Color coordinate cie 1931	Color deviation from black body
CCT	CRI	CRI R9	TM30 Rf	TM30 Rg	CQS	TLCI	x	y	Δuv
4071 K	96,4	96,1	94,2	102,5	96,5	91	0,379	0,379	0,0017

# TM30 DETAILS

**Rf 94,2**  
Fidelity index Rf

**Rg 102,5**  
Gammut index

Hue Bin	R <sub>f</sub>	Graphic shifts (%)	
		Chroma	Hue
1	96	0%	-1%
2	96	1%	-1%
3	95	0%	-1%
4	96	-2%	-2%
5	94	-2%	1%
6	94	2%	3%
7	94	3%	2%
8	93	2%	1%
9	95	2%	2%
10	97	0%	1%
11	93	3%	3%
12	91	3%	0%
13	92	3%	-5%
14	96	1%	1%
15	91	2%	-4%
16	90	2%	-5%

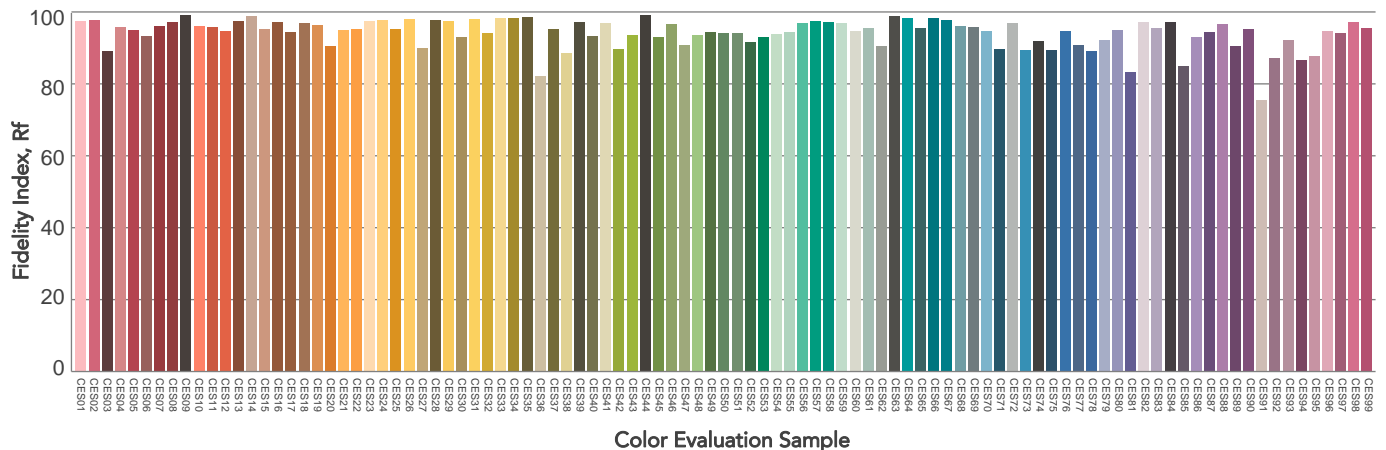
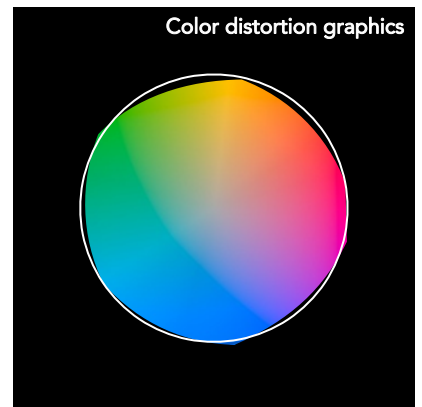
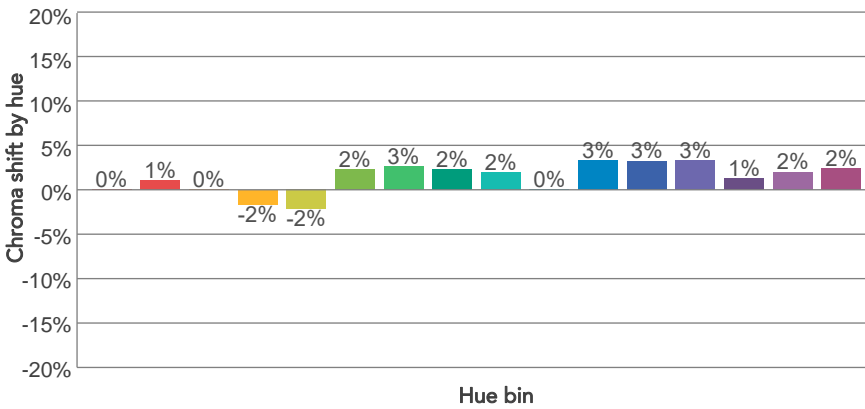
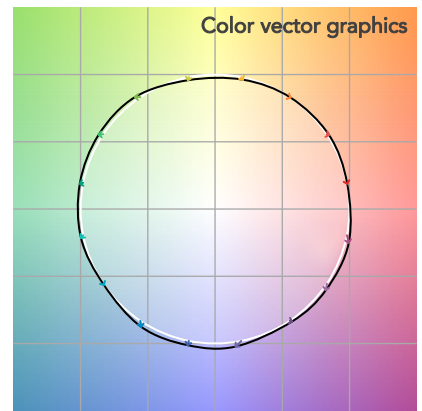
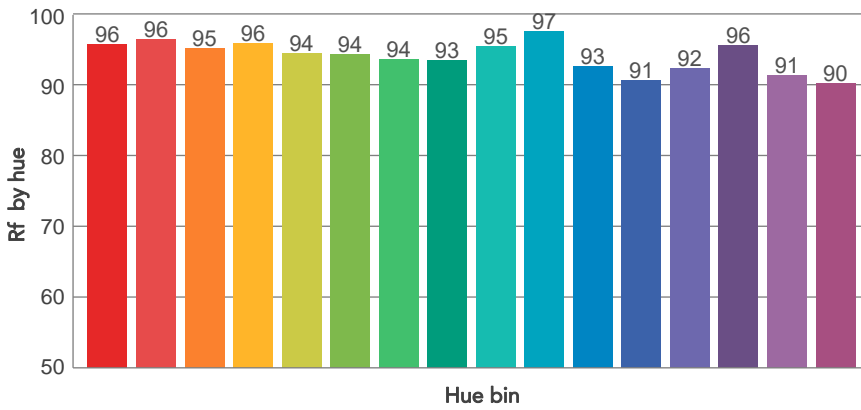
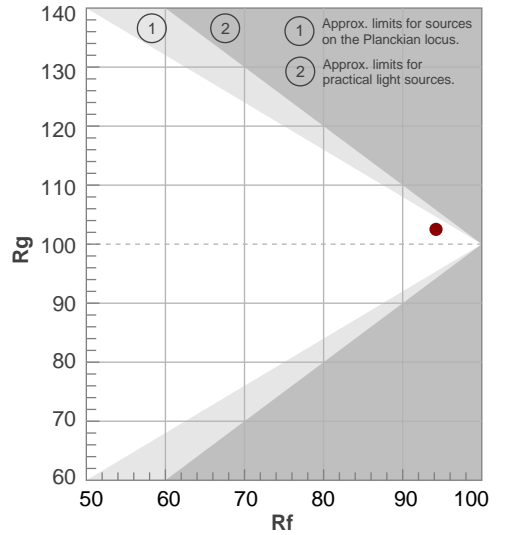

# BEAM DETAILS



Beam angle 50%	Field angle 10%	Cut off angle 2,5%	Intensity ratio in 120° cone	Intensity ratio in 90° cone
56,3°	77°	86,1°	100,0%	99,6%

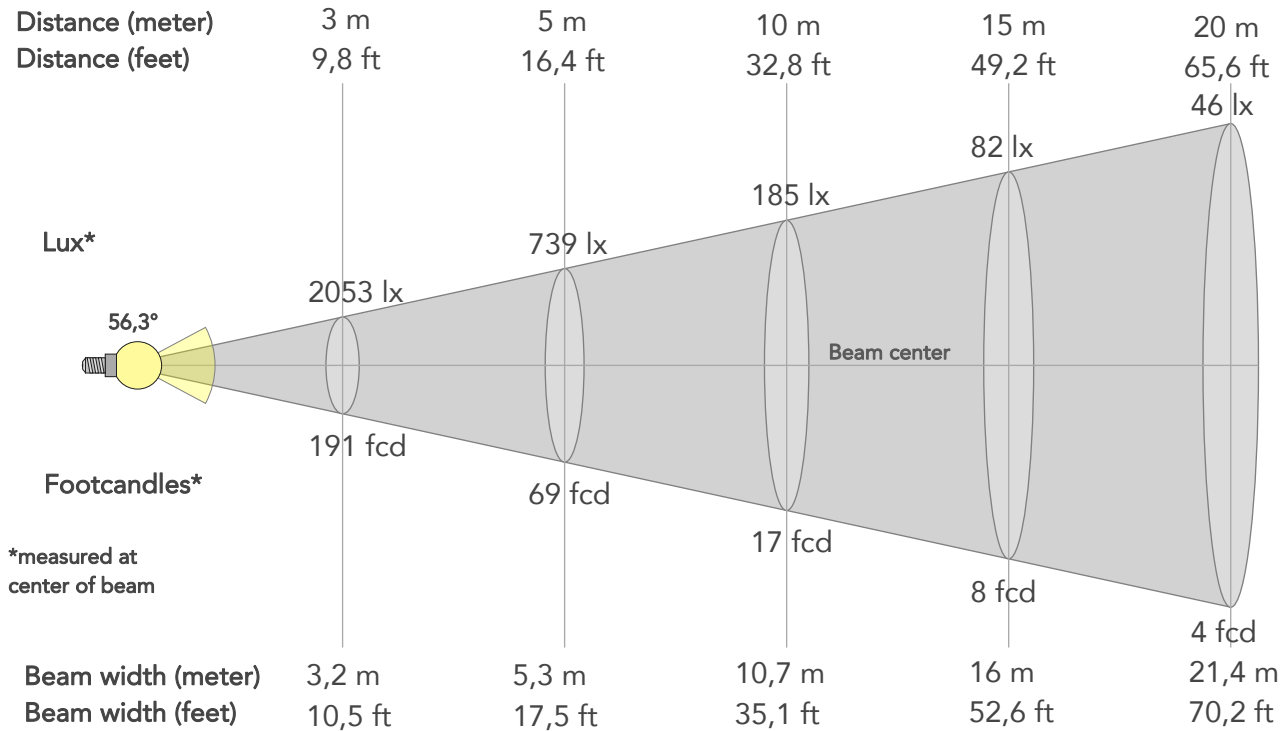

## BEAM INTENSITIES AND WIDTHS

Distance	1m	2m	3m	4m	5m	7,5m	10m	15m	20m	25m	30m	40m	50m
Distance	3,3ft	6,6ft	9,8ft	13,1ft	16,4ft	24,6ft	32,8ft	49,2ft	65,6ft	82ft	98,4ft	131,2ft	164ft
Lux	18478lx	4620lx	2053lx	1155lx	739lx	329lx	185lx	82lx	46lx	30lx	21lx	12lx	7lx
Footcand.	1717fcd	429fcd	191fcd	107fcd	69fcd	31fcd	17fcd	8fcd	4fcd	3fcd	2fcd	1fcd	1fcd
Beam wid.	1,1m	2,1m	3,2m	4,3m	5,3m	8m	10,7m	16m	21,4m	26,7m	32,1m	42,8m	53,5m
Beam wid.	3,5ft	7,1ft	10,5ft	14ft	17,5ft	26,3ft	35,1ft	52,6ft	70,2ft	87,7ft	105,3ft	140,4ft	175,5ft

## LINEAR DISTRIBUTION DIAGRAM

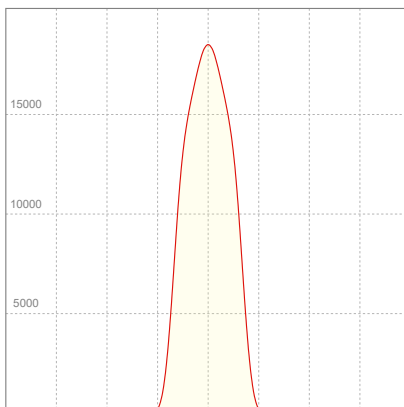

## ELECTRICAL SPECIFICATIONS

Input voltage	Input current	Input power	Effeciency
227V	2,46A	554,8W	25lm/W

## ISO CANDELA DIAGRAM

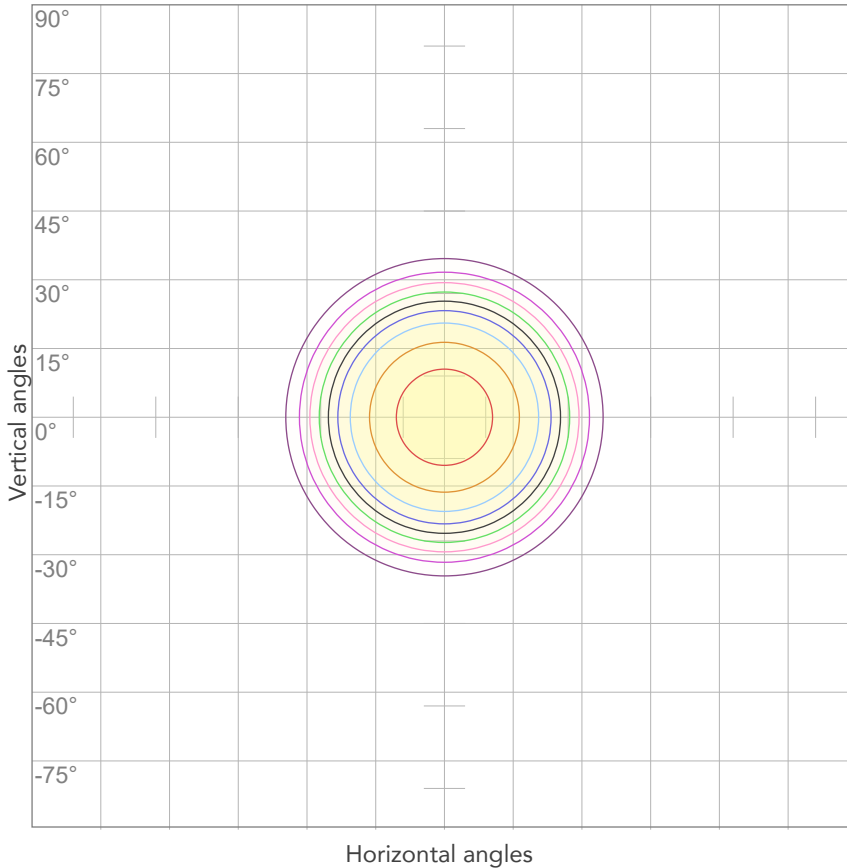

10%	1848 cd
20%	3696 cd
30%	5544 cd
40%	7391 cd
50%	9239 cd
60%	11087 cd
70%	12935 cd
80%	14783 cd

Conditions:

Number of c-planes: 2

Candela at center: 18478 cd

## ISO LUX DIAGRAM

MH: 10,0 m

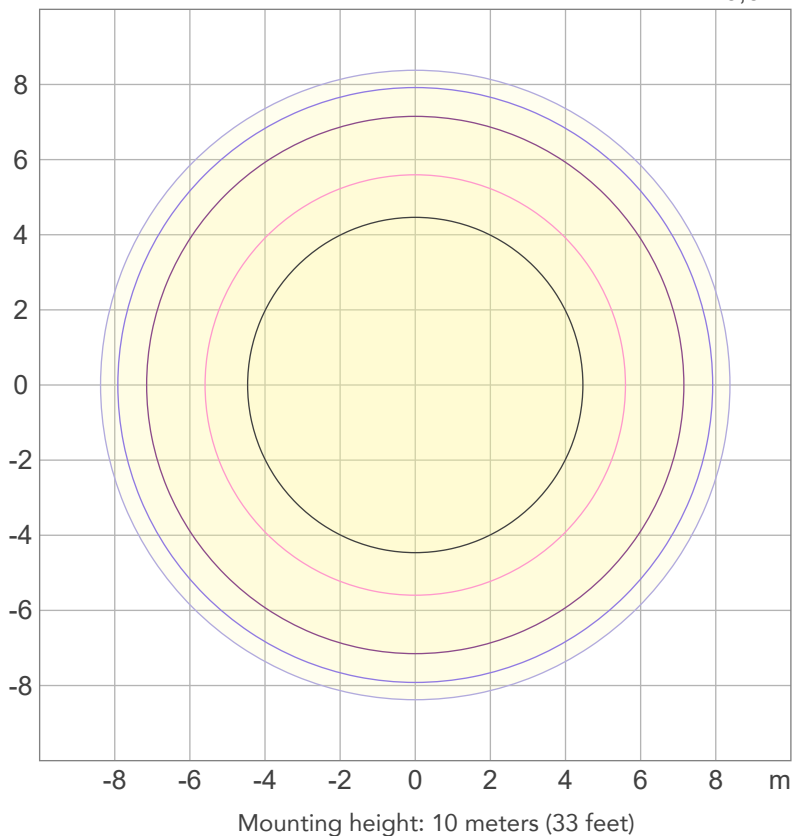

3%	5,54 lx
5%	9,24 lx
10%	18,5 lx
30%	55,4 lx
50%	92,4 lx

Conditions:

Number of c-planes: 2

Lux at center: 185 lx

*Lux distribution on a surface when lamp is mounted at 10 meters from the surface.*



Total lumen output:

10969 lm

Peak candela output:

59285 cd

Light quality:

CRI: 96,6

Color temperature:

4049 K

**PRODUCT NAME:**

**ECLFRCTPLIP**

**MEASURAMENT CONDITIONS:**

Beam angle:

Med Zoom

Target:

4000K - HB

Operator:

Salvatore Giglio

Date and time:

03/10/2023 14:32:58

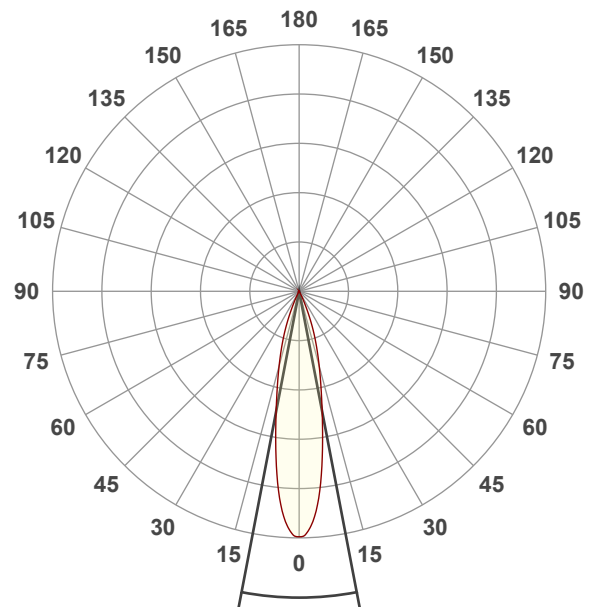

Spectra

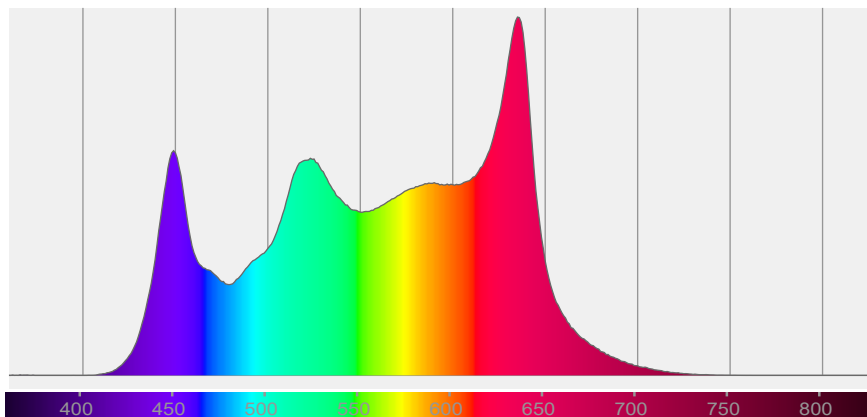

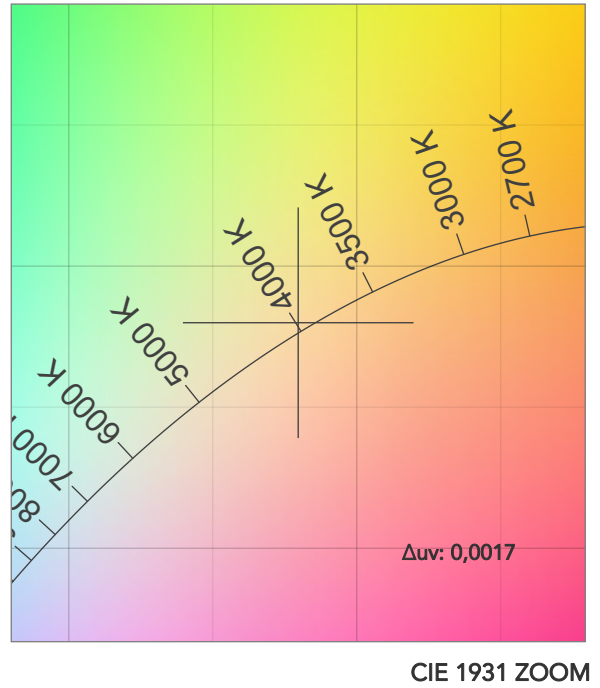
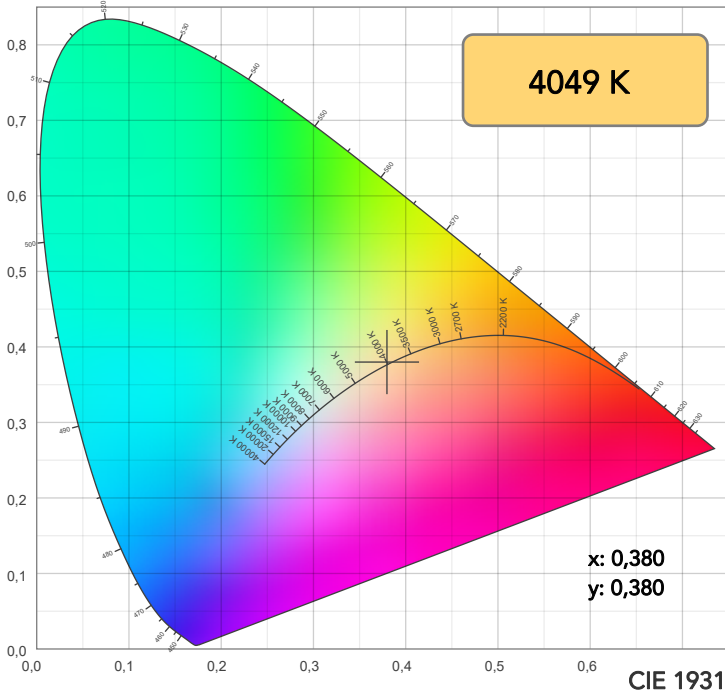

TM30: 94,2

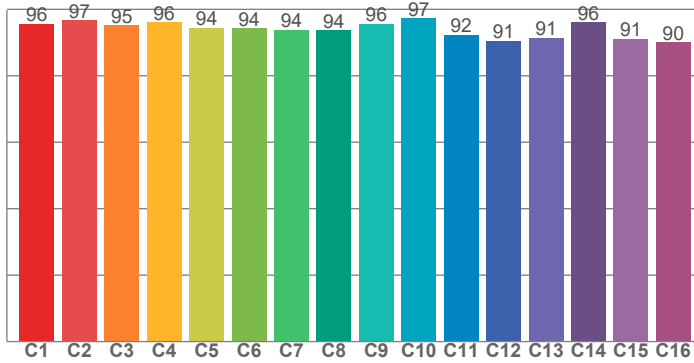

CRI: 96,6 (R1-R8)

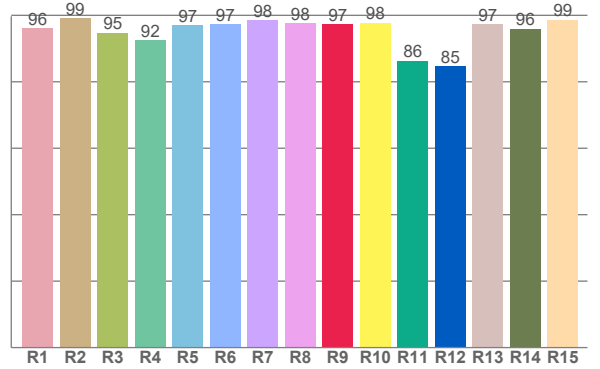

CRI R values, only R1-R8 are used to calculate final CRI value

R1	R2	R3	R4	R5	R6	R7	R8	R9	R10	R11	R12	R13	R14	R15
96,2	99,2	94,7	92,5	96,9	97,3	98,5	97,6	97,4	97,7	86,4	84,8	97,3	95,9	98,7

TM30 C values, 16 binned values out of total of 99 C values

C1	C2	C3	C4	C5	C6	C7	C8	C9	C10	C11	C12	C13	C14	C15	C16
95,7	96,6	95,2	96,1	94,3	94,3	93,7	93,7	95,6	97,3	92,4	90,5	91,4	96,1	91,1	90,1

CQS Q values

Q1	Q2	Q3	Q4	Q5	Q6	Q7	Q8	Q9	Q10	Q11	Q12	Q13	Q14	Q15
96,5	97,5	94,7	98,9	96,2	94,8	97,8	98,0	98,1	98,7	95,4	95,4	96,1	98,4	98,2

CQS: 96,7

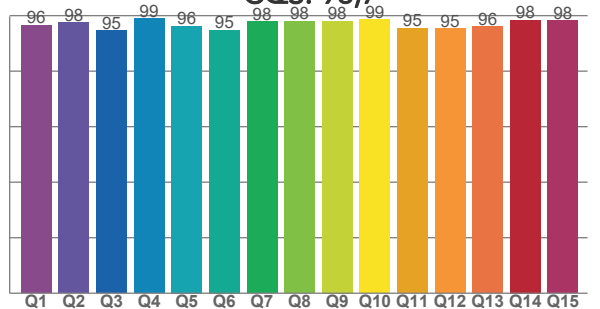

COLOR PARAMETERS

Color temperature	Color rendering index	Red component	Color fidelity	Color gamut	Color quality scale	Television lighting index	Color coordinate cie 1931	Color coordinate cie 1931	Color deviation from black body
CCT	CRI	CRI R9	TM30 Rf	TM30 Rg	CQS	TLCI	x	y	Δuv
4049 K	96,6	97,4	94,2	102,4	96,7	91	0,380	0,380	0,0017



# TM30 DETAILS

**Rf 94,2**  
Fidelity index Rf

**Rg 102,4**  
Gammut index

Hue Bin	R <sub>f</sub>	Graphic shifts (%)	
		Chroma	Hue
1	96	0%	-1%
2	97	1%	-1%
3	95	0%	0%
4	96	-2%	-1%
5	94	-2%	1%
6	94	2%	3%
7	94	3%	2%
8	94	2%	1%
9	96	2%	2%
10	97	0%	1%
11	92	3%	3%
12	91	3%	0%
13	91	3%	-5%
14	96	2%	1%
15	91	2%	-5%
16	90	2%	-5%

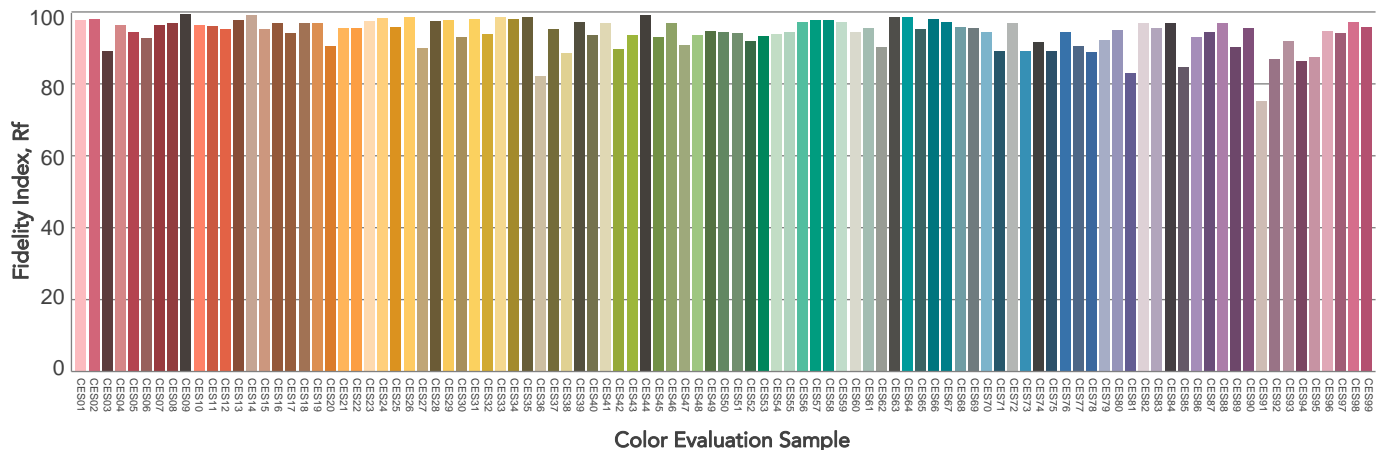
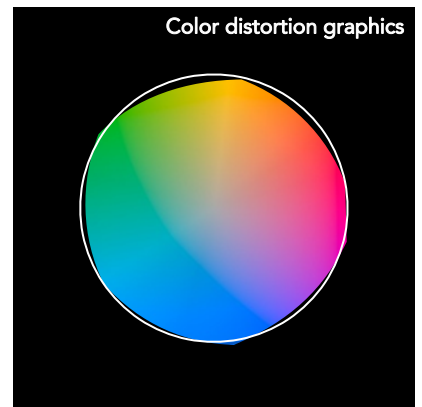
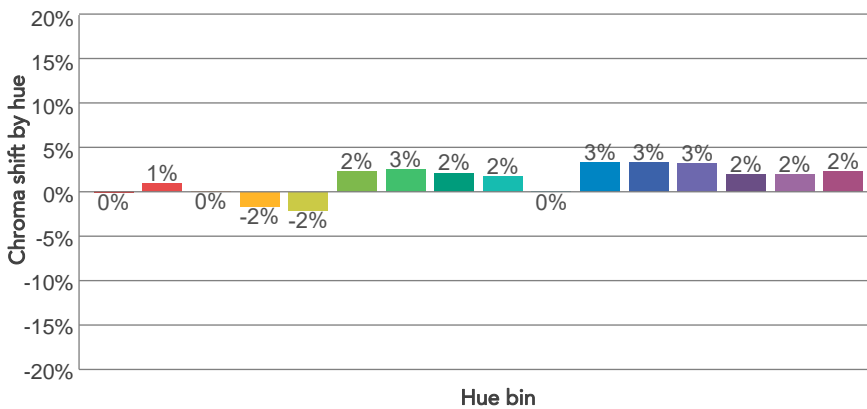
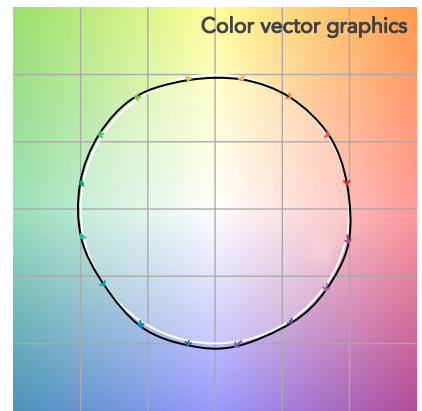
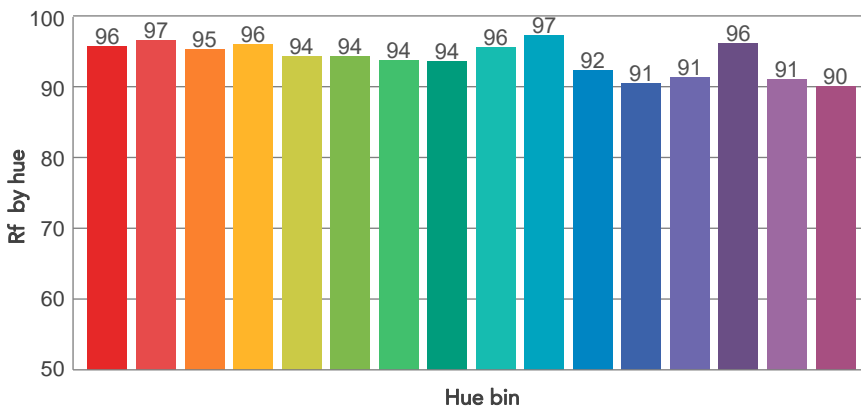
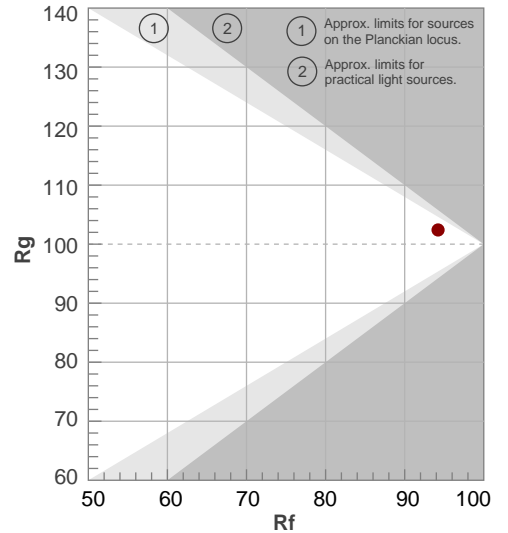

# BEAM DETAILS



Beam angle 50%	Field angle 10%	Cut off angle 2,5%	Intensity ratio in 120° cone	Intensity ratio in 90° cone
21,7°	44,7°	53,2°	100,0%	100,0%

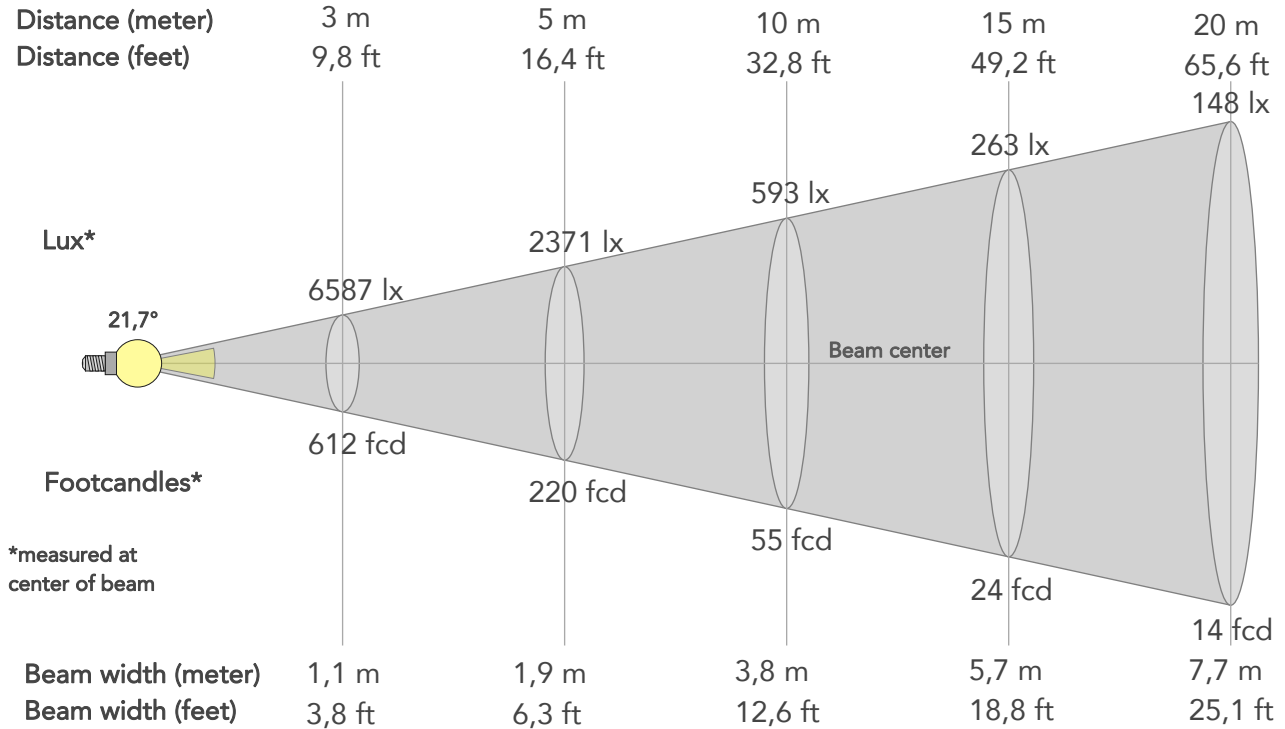

## BEAM INTENSITIES AND WIDTHS

Distance	1m	2m	3m	4m	5m	7,5m	10m	15m	20m	25m	30m	40m	50m
Distance	3,3ft	6,6ft	9,8ft	13,1ft	16,4ft	24,6ft	32,8ft	49,2ft	65,6ft	82ft	98,4ft	131,2ft	164ft
Lux	59285lx	14821lx	6587lx	3705lx	2371lx	1054lx	593lx	263lx	148lx	95lx	66lx	37lx	24lx
Footcand.	5508fcd	1377fcd	612fcd	344fcd	220fcd	98fcd	55fcd	24fcd	14fcd	9fcd	6fcd	3fcd	2fcd
Beam wid.	0,4m	0,8m	1,1m	1,5m	1,9m	2,9m	3,8m	5,7m	7,7m	9,6m	11,5m	15,3m	19,1m
Beam wid.	1,3ft	2,5ft	3,8ft	5ft	6,3ft	9,4ft	12,6ft	18,8ft	25,1ft	31,4ft	37,7ft	50,2ft	62,8ft

## LINEAR DISTRIBUTION DIAGRAM

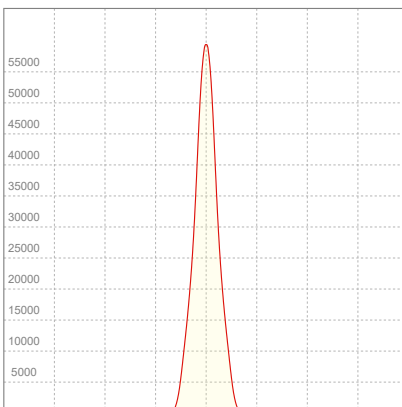

## ELECTRICAL SPECIFICATIONS

Input voltage	Input current	Input power	Effeciency
224V	2,49A	552,5W	20lm/W

## ISO CANDELA DIAGRAM

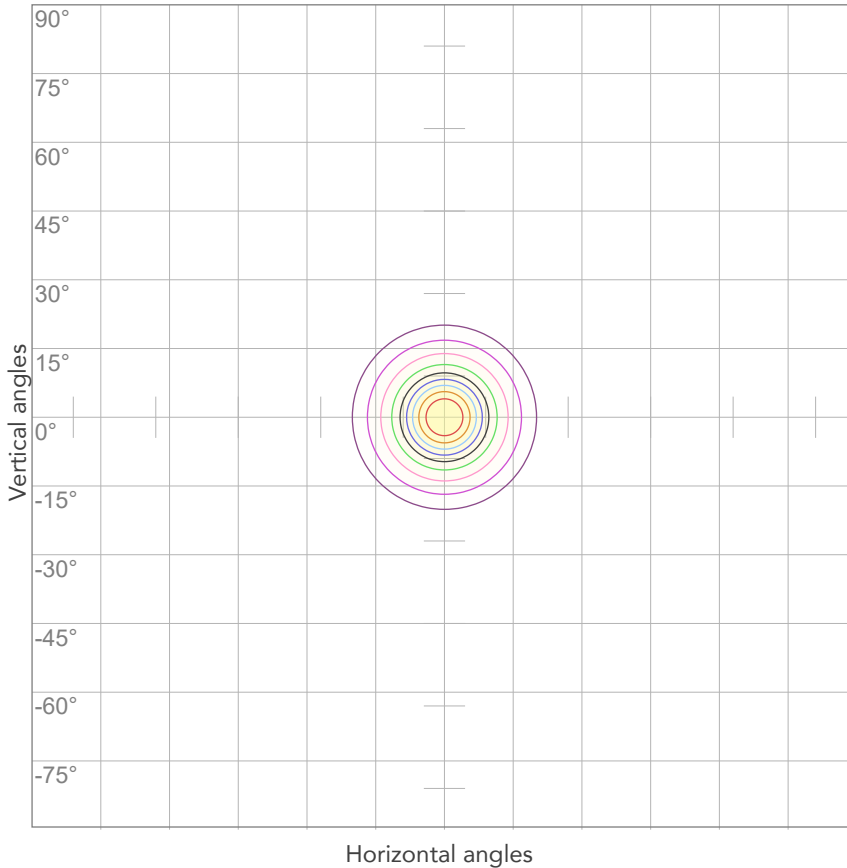

10%	5928 cd
20%	11857 cd
30%	17785 cd
40%	23714 cd
50%	29642 cd
60%	35571 cd
70%	41499 cd
80%	47428 cd

Conditions:

Number of c-planes: 2

Candela at center: 59285 cd

## ISO LUX DIAGRAM

MH: 10,0 m

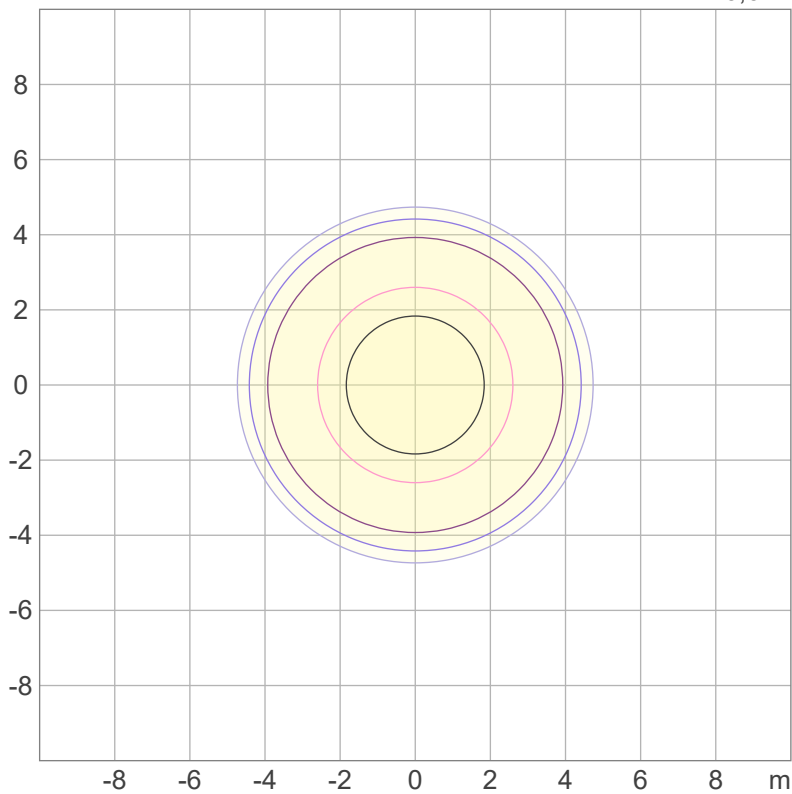

3%	17,8 lx
5%	29,6 lx
10%	59,3 lx
30%	178 lx
50%	296 lx

Conditions:

Number of c-planes: 2

Lux at center: 593 lx

*Lux distribution on a surface when lamp is mounted at 10 meters from the surface.*



Total lumen output:

6108 lm

Peak candela output:

157582 cd

Light quality:

CRI: 96,9

Color temperature:

4065 K

**PRODUCT NAME:**  
**ECLFRCTPLIP**

**MEASURAMENT CONDITIONS:**

Beam angle:

Min Zoom

Target:

4000K - HB

Operator:

Salvatore Giglio

Date and time:

03/10/2023 14:10:03

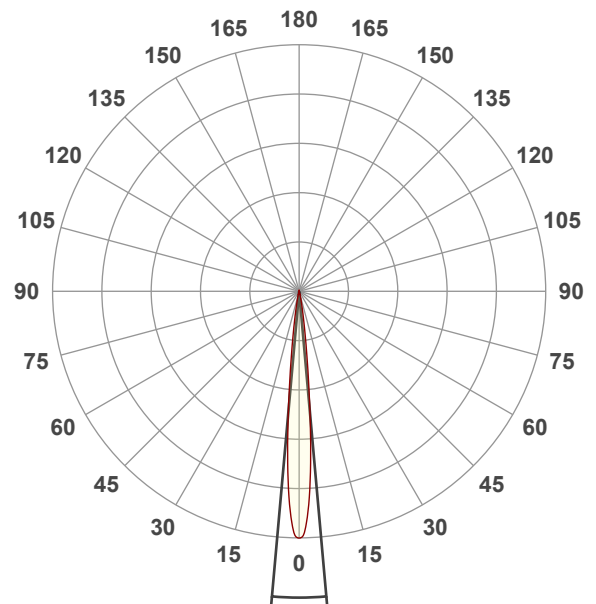

Beam angle 50%: 10,2°

Field angle 10%: 18,8°

Cut off angle 2.5%: 26,1°

Spectra

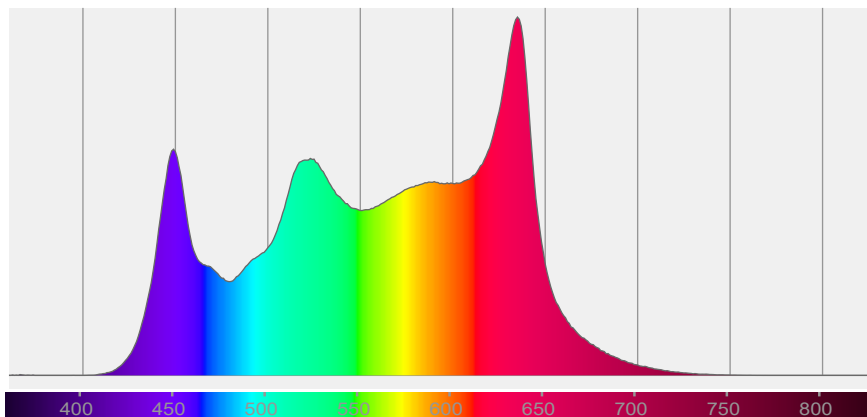

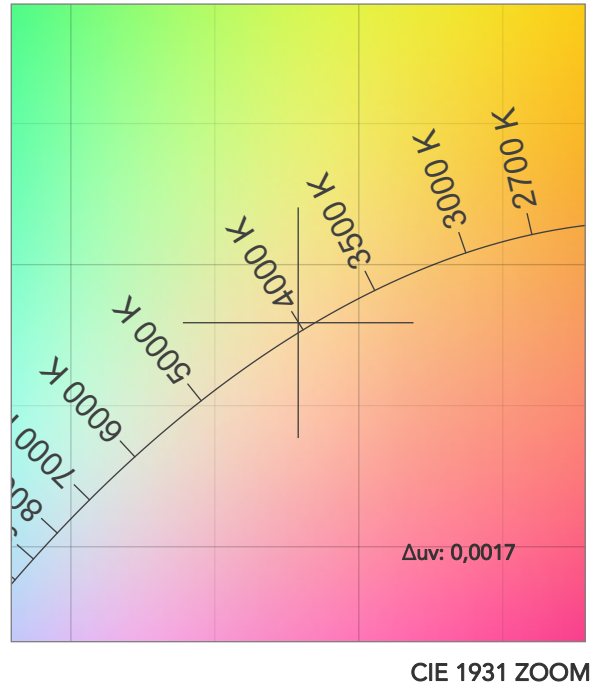
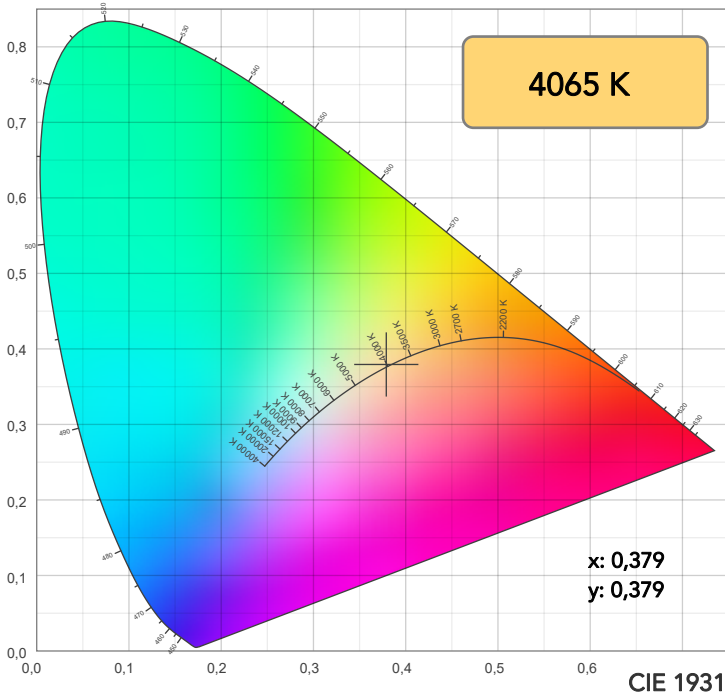

TM30: 94,2

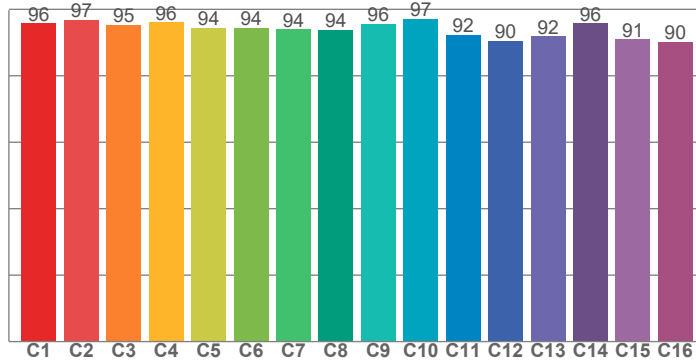

CRI: 96,9 (R1-R8)

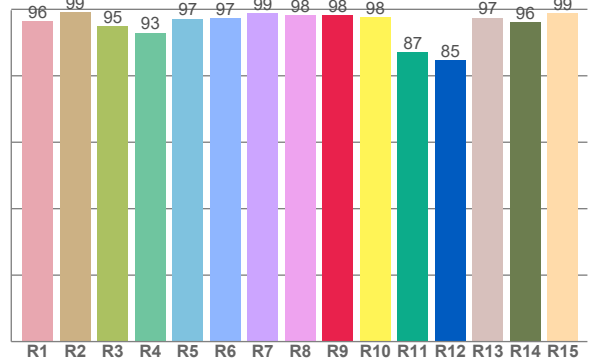

CRI R values, only R1-R8 are used to calculate final CRI value

R1	R2	R3	R4	R5	R6	R7	R8	R9	R10	R11	R12	R13	R14	R15
96,4	99,2	95,0	93,0	97,2	97,3	98,8	98,3	98,3	97,7	87,0	84,6	97,4	96,1	98,7

TM30 C values, 16 binned values out of total of 99 C values

C1	C2	C3	C4	C5	C6	C7	C8	C9	C10	C11	C12	C13	C14	C15	C16
95,7	96,8	95,3	96,1	94,4	94,5	93,9	93,8	95,7	97,1	92,3	90,5	91,9	95,7	90,9	90,2

CQS Q values

Q1	Q2	Q3	Q4	Q5	Q6	Q7	Q8	Q9	Q10	Q11	Q12	Q13	Q14	Q15
96,1	97,4	94,6	98,8	96,6	95,2	97,9	98,1	98,2	98,6	95,6	95,6	96,4	98,3	98,0

CQS: 96,8

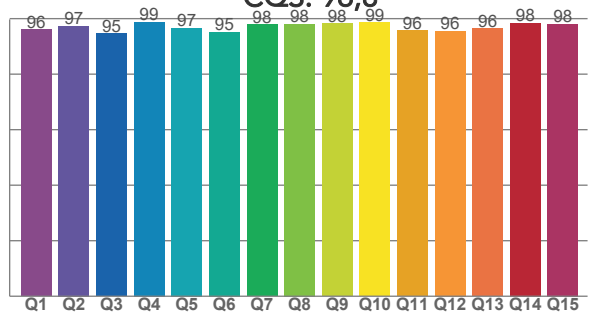

COLOR PARAMETERS

Color temperature	Color rendering index	Red component	Color fidelity	Color gamut	Color quality scale	Television lighting index	Color coordinate cie 1931	Color coordinate cie 1931	Color deviation from black body
CCT	CRI	CRI R9	TM30 Rf	TM30 Rg	CQS	TLCI	x	y	Δuv
4065 K	96,9	98,3	94,2	102,2	96,8	91	0,379	0,379	0,0017

# TM30 DETAILS

**Rf 94,2**  
Fidelity index Rf

**Rg 102,2**  
Gammut index

Hue Bin	R <sub>f</sub>	Graphic shifts (%)	
		Chroma	Hue
1	96	0%	-1%
2	97	1%	-1%
3	95	0%	0%
4	96	-2%	-1%
5	94	-2%	1%
6	94	2%	3%
7	94	2%	2%
8	94	2%	1%
9	96	2%	2%
10	97	0%	1%
11	92	3%	3%
12	90	3%	0%
13	92	3%	-5%
14	96	1%	1%
15	91	2%	-5%
16	90	2%	-5%

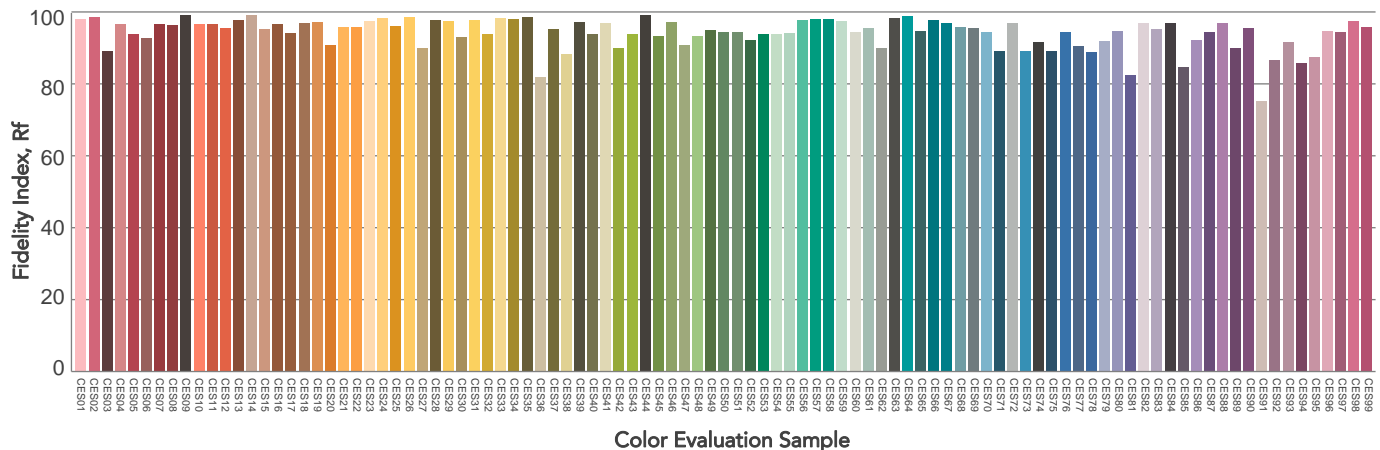
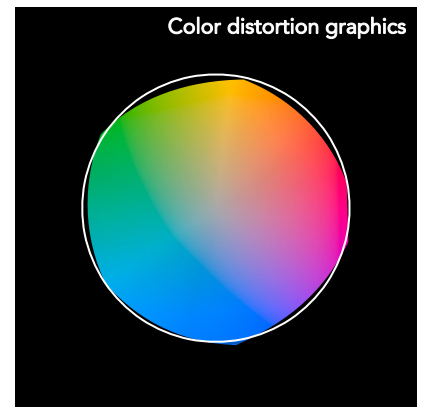
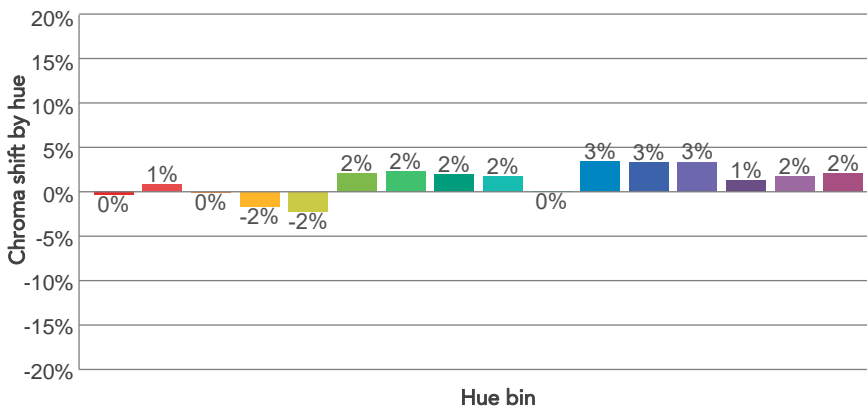
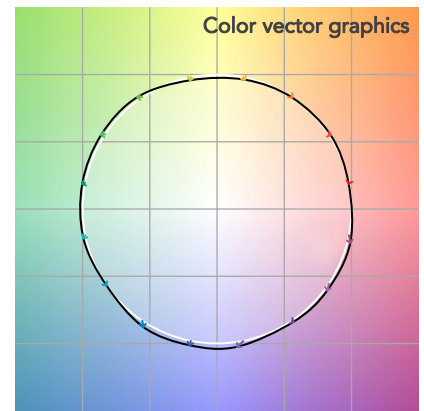
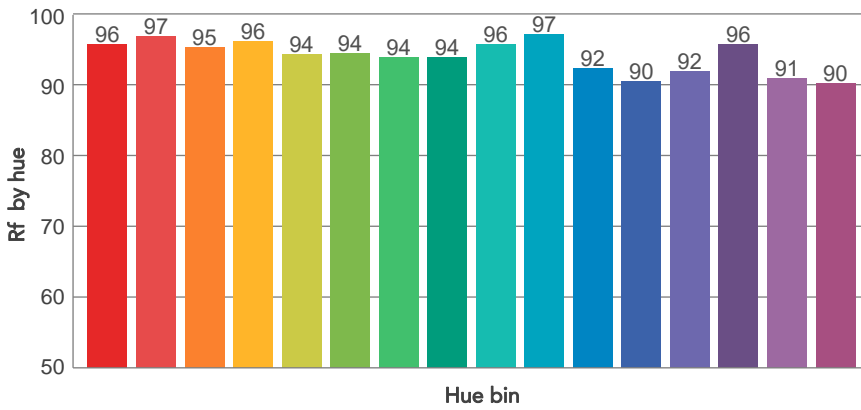
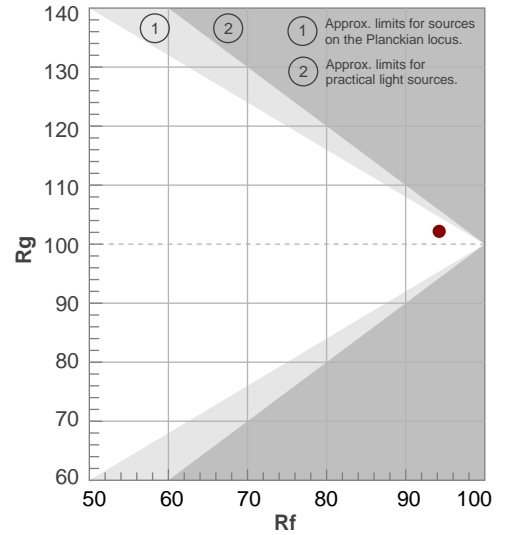

# BEAM DETAILS



Beam angle 50%	Field angle 10%	Cut off angle 2,5%	Intensity ratio in 120° cone	Intensity ratio in 90° cone
10,2°	18,8°	26,1°	100,0%	100,0%

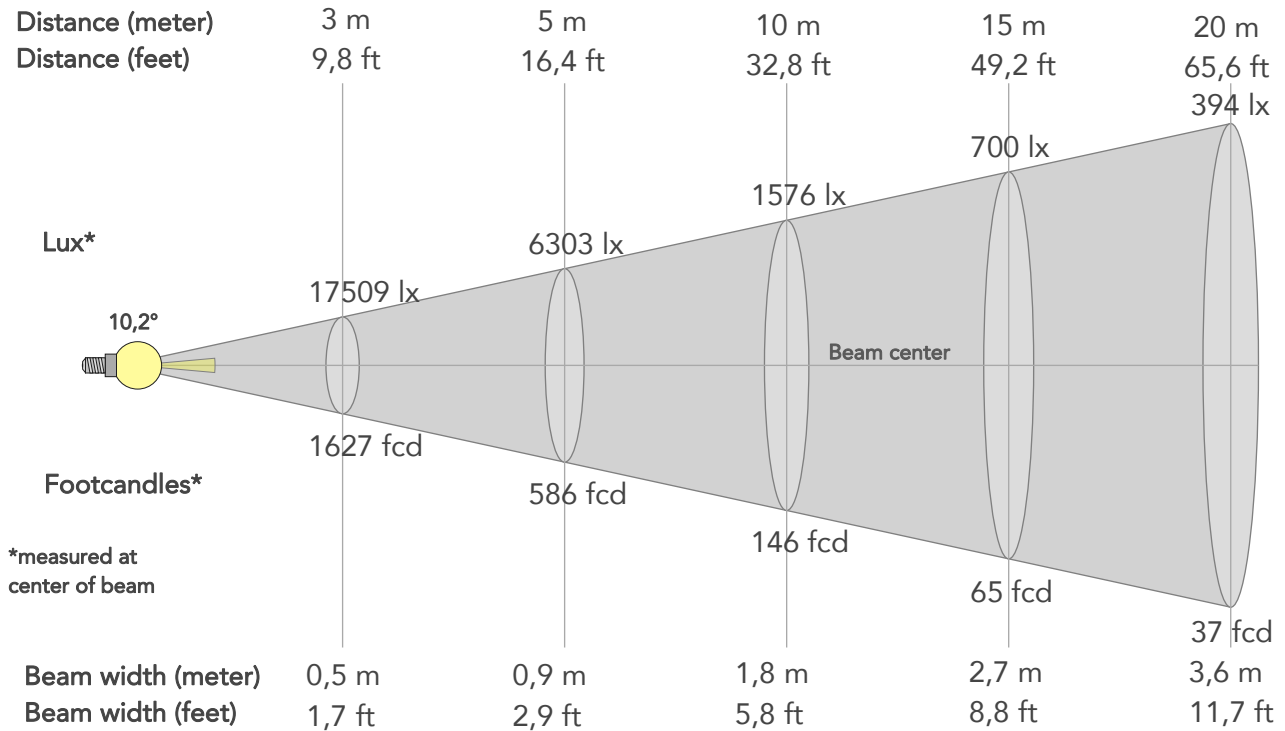

## BEAM INTENSITIES AND WIDTHS

Distance	1m	2m	3m	4m	5m	7,5m	10m	15m	20m	25m	30m	40m	50m
Distance	3,3ft	6,6ft	9,8ft	13,1ft	16,4ft	24,6ft	32,8ft	49,2ft	65,6ft	82ft	98,4ft	131,2ft	164ft
Lux	157582lx	39396lx	17509lx	9849lx	6303lx	2801lx	1576lx	700lx	394lx	252lx	175lx	98lx	63lx
Footcand.	14640fcd	3660fcd	1627fcd	915fcd	586fcd	260fcd	146fcd	65fcd	37fcd	23fcd	16fcd	9fcd	6fcd
Beam wid.	0,2m	0,4m	0,5m	0,7m	0,9m	1,3m	1,8m	2,7m	3,6m	4,5m	5,3m	7,1m	8,9m
Beam wid.	0,6ft	1,2ft	1,7ft	2,3ft	2,9ft	4,4ft	5,8ft	8,8ft	11,7ft	14,6ft	17,5ft	23,4ft	29,2ft

## LINEAR DISTRIBUTION DIAGRAM

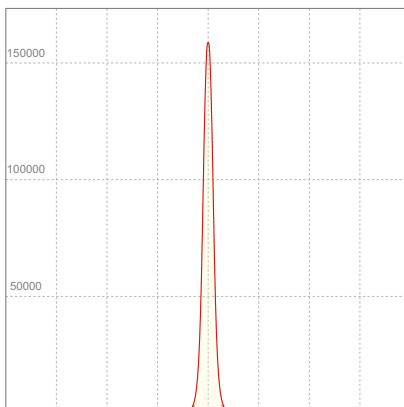

## ELECTRICAL SPECIFICATIONS

Input voltage	Input current	Input power	Effeciency
226V	2,45A	550,5W	11lm/W

## ISO CANDELA DIAGRAM

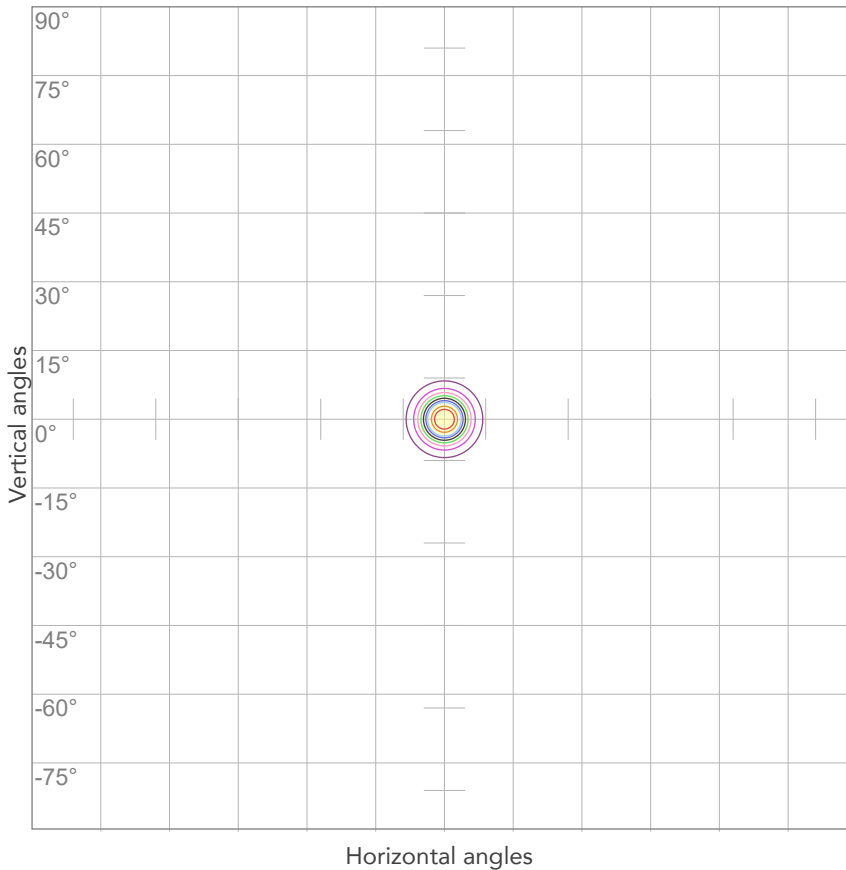

10%	15758 cd
20%	31516 cd
30%	47275 cd
40%	63033 cd
50%	78791 cd
60%	94549 cd
70%	110308 cd
80%	126066 cd

Conditions:

Number of c-planes: 2

Candela at center: 157582 cd

## ISO LUX DIAGRAM

MH: 10,0 m

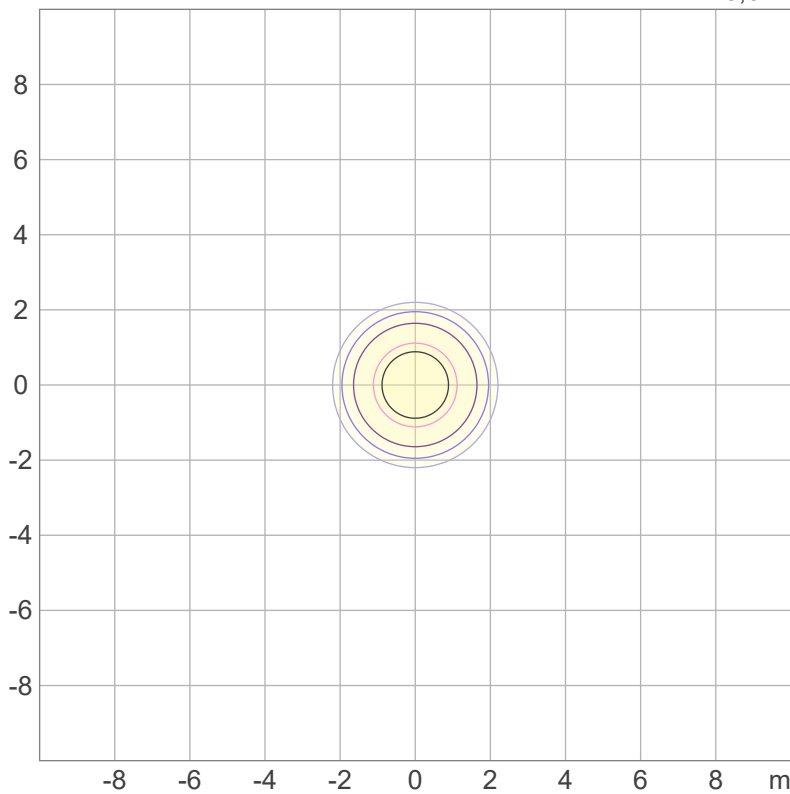

Mounting height: 10 meters (33 feet)

3%	47,3 lx
5%	78,8 lx
10%	158 lx
30%	473 lx
50%	788 lx

Conditions:

Number of c-planes: 2

Lux at center: 1576 lx

*Lux distribution on a surface when lamp is mounted at 10 meters from the surface.*





Total lumen output:

12911 lm

Peak candela output:

16785 cd

Light quality:

CRI: 96,1

Color temperature:

5610 K

**PRODUCT NAME:**  
**ECLFRCTPLIP**

**MEASURAMENT CONDITIONS:**

Beam angle:  
Max Zoom

Target:  
5600K - HB

Operator:  
Salvatore Giglio

Date and time:  
03/10/2023 13:09:47

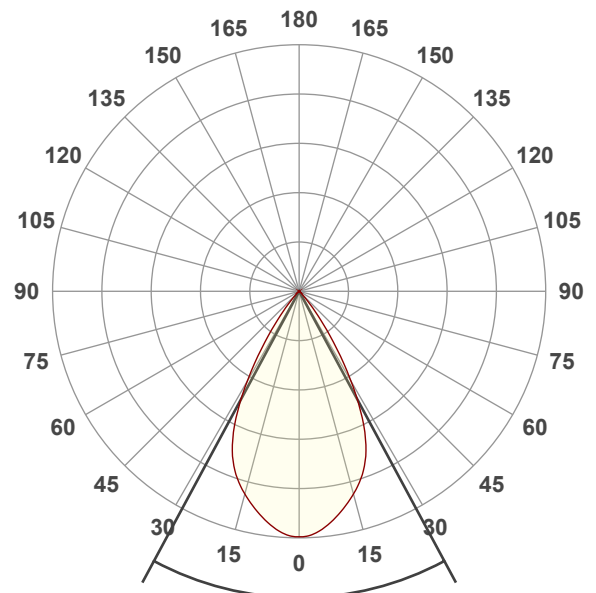

Beam angle 50%: 56,6°  
Field angle 10%: 77,7°  
Cut off angle 2.5%: 87°

Spectra

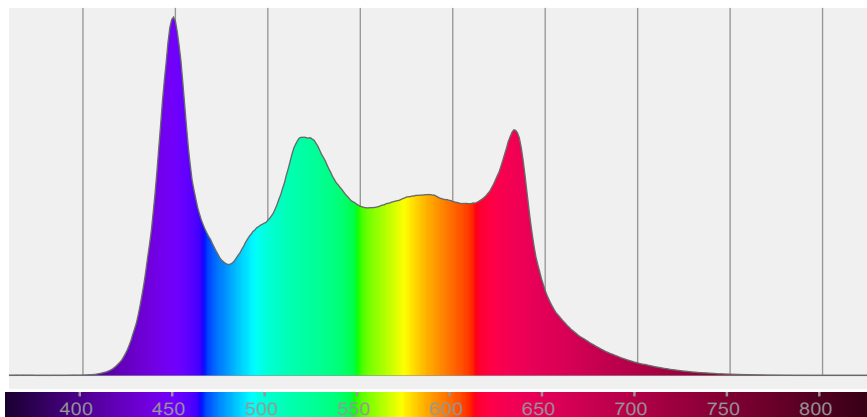

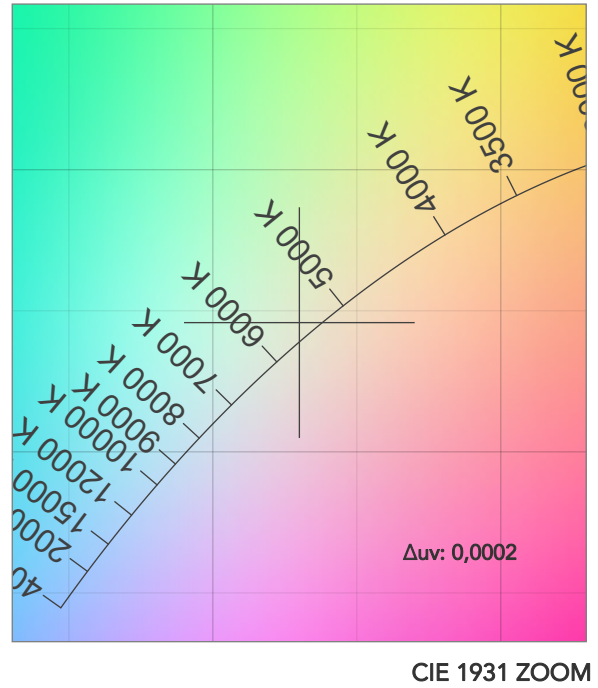
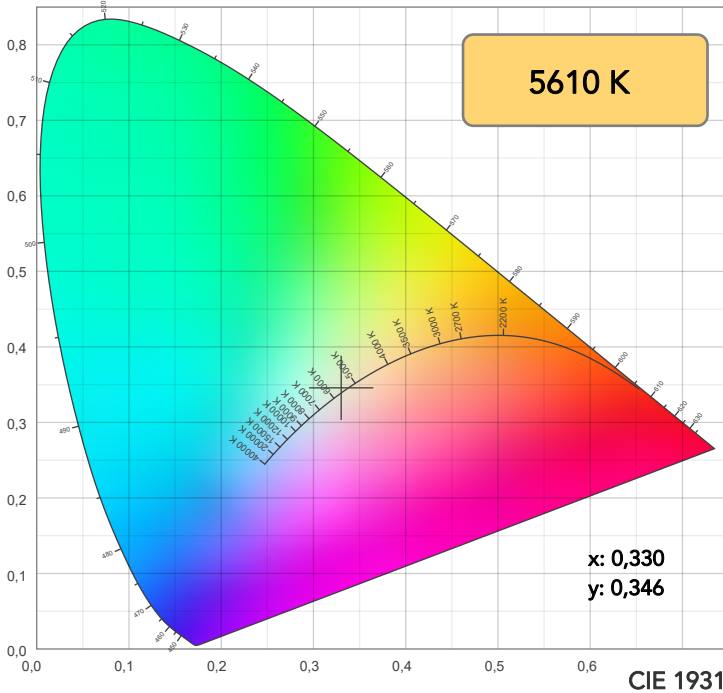

TM30: 93,7

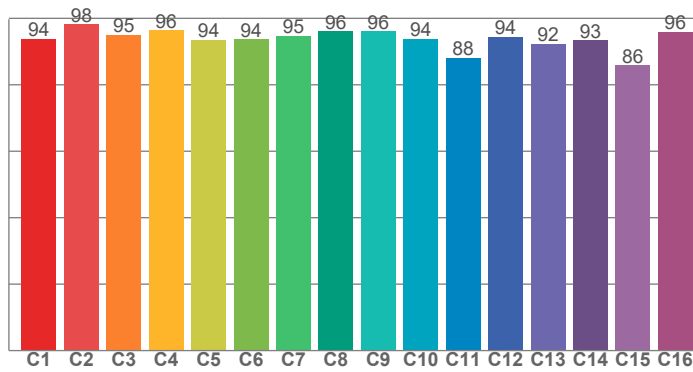

CRI: 96,1 (R1-R8)

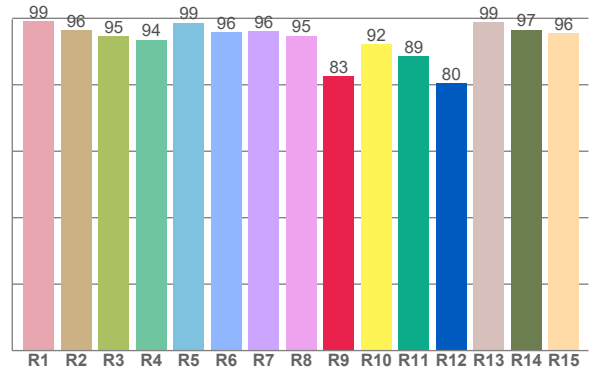

CRI R values, only R1-R8 are used to calculate final CRI value

R1	R2	R3	R4	R5	R6	R7	R8	R9	R10	R11	R12	R13	R14	R15
99,1	96,4	94,6	93,5	98,7	95,8	96,1	94,7	82,6	92,2	88,5	80,5	98,8	96,6	95,6

TM30 C values, 16 binned values out of total of 99 C values

C1	C2	C3	C4	C5	C6	C7	C8	C9	C10	C11	C12	C13	C14	C15	C16
93,8	98,2	95,0	96,3	93,6	93,7	94,8	96,1	96,1	93,9	88,1	94,5	92,3	93,3	85,8	95,9

CQS Q values

Q1	Q2	Q3	Q4	Q5	Q6	Q7	Q8	Q9	Q10	Q11	Q12	Q13	Q14	Q15
94,9	99,1	89,7	94,6	97,3	94,1	96,2	99,3	97,7	95,9	99,0	99,3	99,4	95,0	94,6

CQS: 95,5

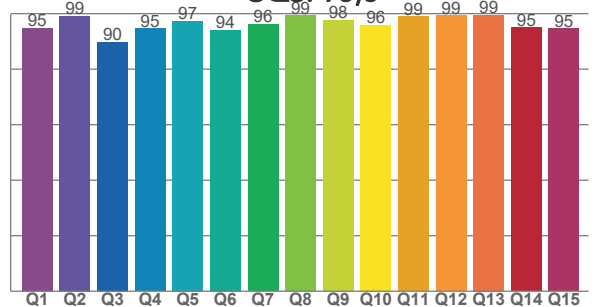

COLOR PARAMETERS

Color temperature	Color rendering index	Red component	Color fidelity	Color gamut	Color quality scale	Television lighting index	Color coordinate cie 1931	Color coordinate cie 1931	Color deviation from black body
CCT	CRI	CRI R9	TM30 Rf	TM30 Rg	CQS	TLCI	x	y	Δuv
5610 K	96,1	82,6	93,7	102,2	95,5	93	0,330	0,346	0,0002

# TM30 DETAILS

**Rf 93,7**  
Fidelity index Rf

**Rg 102,2**  
Gammut index

Hue Bin	R <sub>f</sub>	Graphic shifts (%)	
		Chroma	Hue
1	94	-2%	-1%
2	98	-1%	1%
3	95	-1%	2%
4	96	-1%	1%
5	94	-1%	2%
6	94	4%	2%
7	95	2%	0%
8	96	0%	0%
9	96	-1%	2%
10	94	-1%	3%
11	88	2%	7%
12	94	3%	0%
13	92	5%	-4%
14	93	3%	-2%
15	86	7%	-11%
16	96	1%	-2%

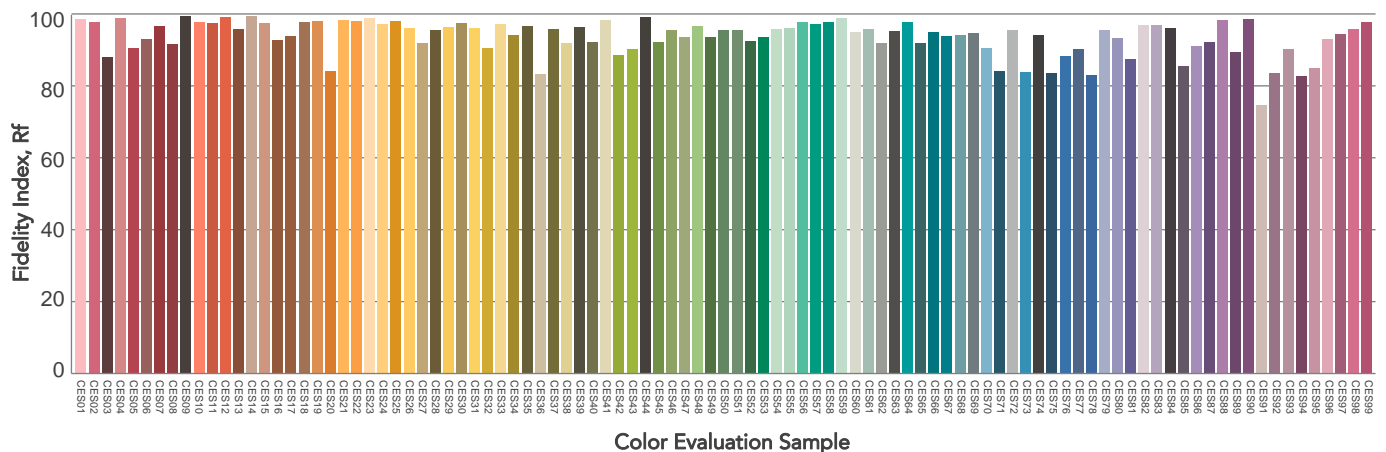
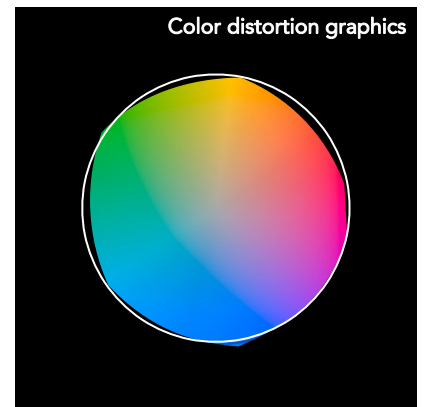
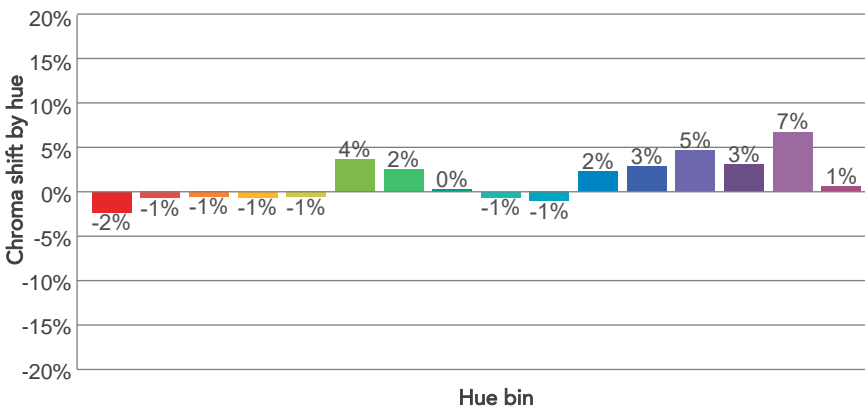
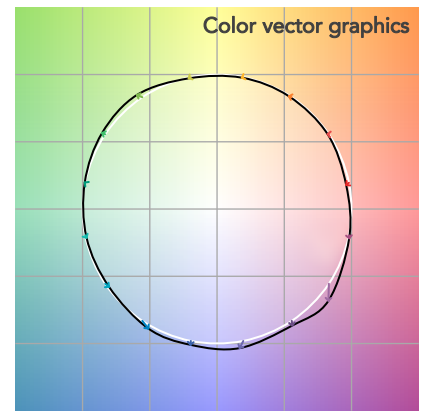
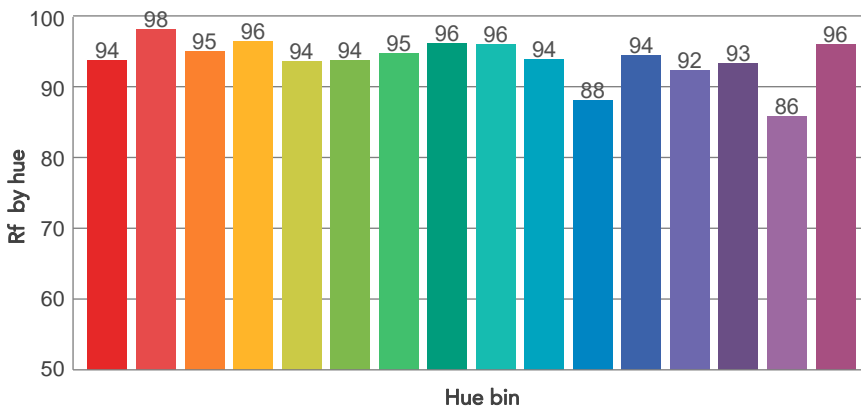
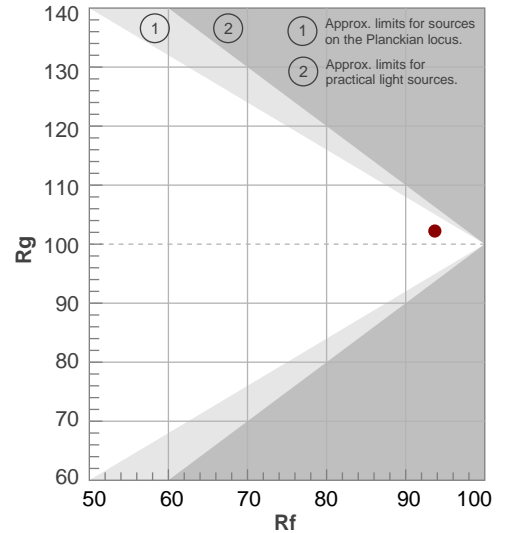

# BEAM DETAILS



Beam angle 50%	Field angle 10%	Cut off angle 2,5%	Intensity ratio in 120° cone	Intensity ratio in 90° cone
56,6°	77,7°	87°	100,0%	99,4%

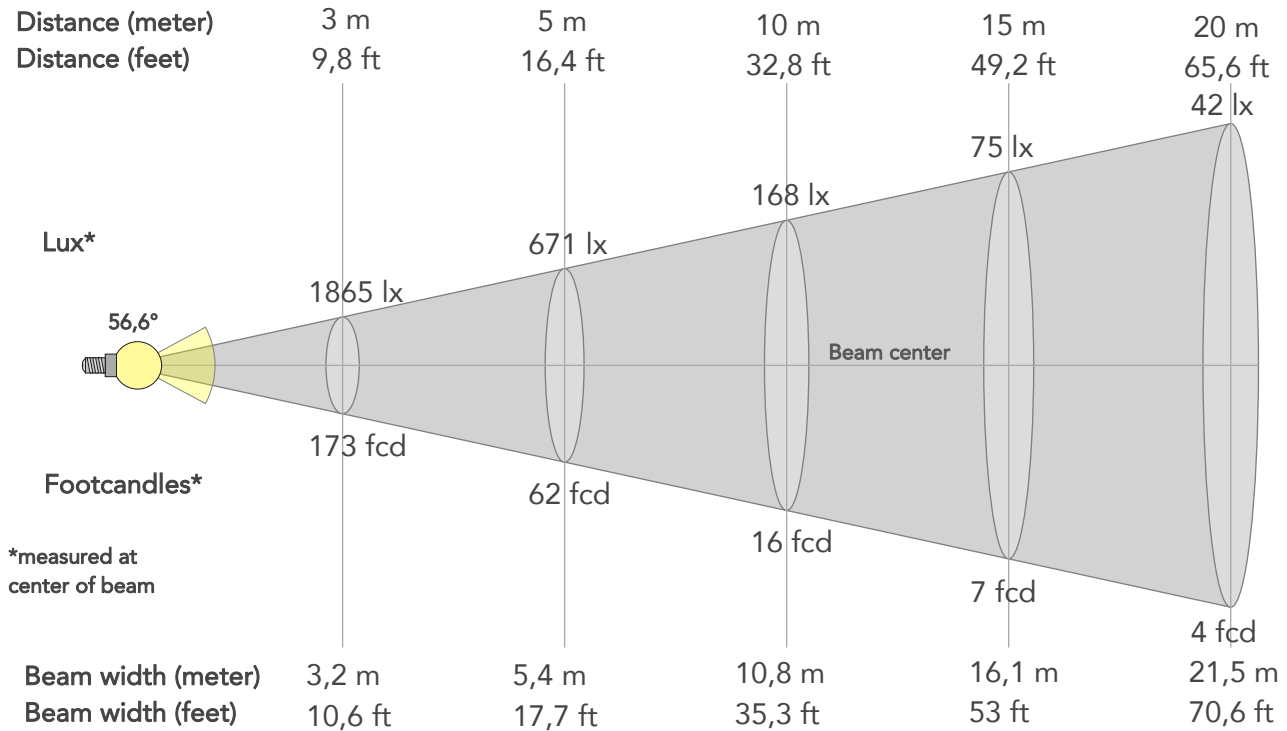

## BEAM INTENSITIES AND WIDTHS

Distance	1m	2m	3m	4m	5m	7,5m	10m	15m	20m	25m	30m	40m	50m
Distance	3,3ft	6,6ft	9,8ft	13,1ft	16,4ft	24,6ft	32,8ft	49,2ft	65,6ft	82ft	98,4ft	131,2ft	164ft
Lux	16785lx	4196lx	1865lx	1049lx	671lx	298lx	168lx	75lx	42lx	27lx	19lx	10lx	7lx
Footcand.	1559fcd	390fcd	173fcd	97fcd	62fcd	28fcd	16fcd	7fcd	4fcd	2fcd	2fcd	1fcd	1fcd
Beam wid.	1,1m	2,2m	3,2m	4,3m	5,4m	8,1m	10,8m	16,1m	21,5m	26,9m	32,3m	43,1m	53,8m
Beam wid.	3,6ft	7,1ft	10,6ft	14,1ft	17,7ft	26,5ft	35,3ft	53ft	70,6ft	88,3ft	105,9ft	141,3ft	176,6ft

## LINEAR DISTRIBUTION DIAGRAM

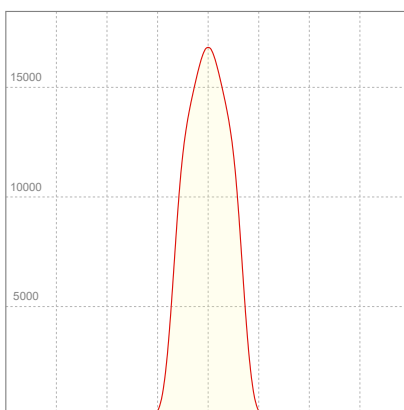

## ELECTRICAL SPECIFICATIONS

Input voltage	Input current	Input power	Effeciency
227V	2,27A	513,1W	25lm/W

## ISO CANDELA DIAGRAM

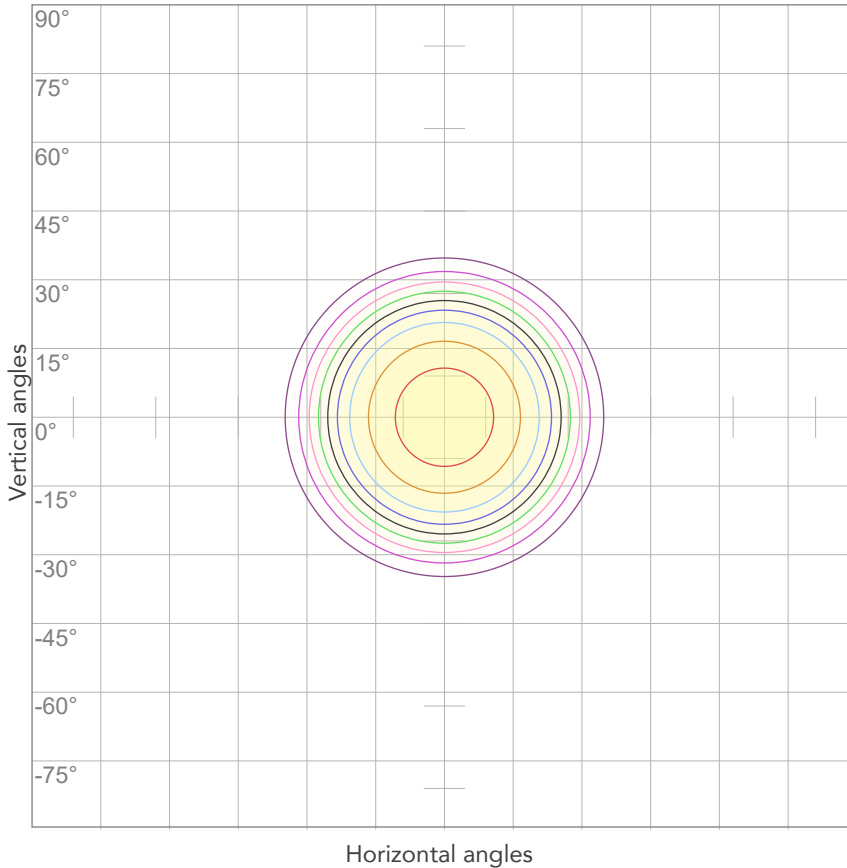

10%	1678 cd
20%	3357 cd
30%	5035 cd
40%	6714 cd
50%	8392 cd
60%	10071 cd
70%	11749 cd
80%	13428 cd

Conditions:

Number of c-planes: 2

Candela at center: 16785 cd

## ISO LUX DIAGRAM

MH: 10,0 m

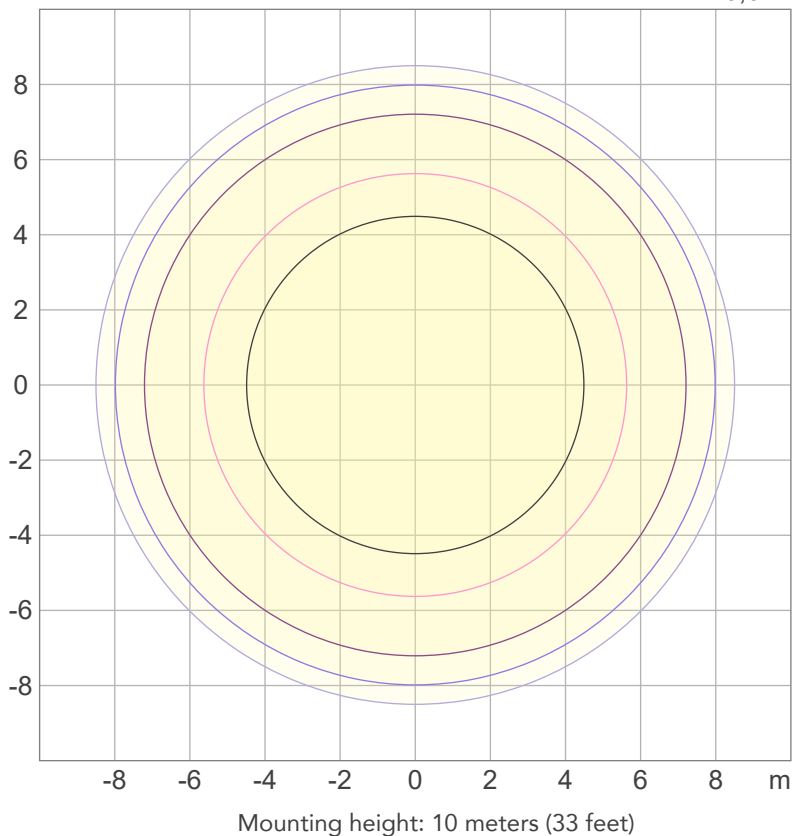

3%	5,04 lx
5%	8,39 lx
10%	16,8 lx
30%	50,4 lx
50%	83,9 lx

Conditions:

Number of c-planes: 2

Lux at center: 168 lx

*Lux distribution on a surface when lamp is mounted at 10 meters from the surface.*



Total lumen output:

10633 lm

Peak candela output:

55829 cd

Light quality:

CRI: 96,1

Color temperature:

5649 K

**PRODUCT NAME:**

**ECLFRCTPLIP**

**MEASURAMENT CONDITIONS:**

Beam angle:

Med Zoom

Target:

5600K - HB

Operator:

Salvatore Giglio

Date and time:

03/10/2023 14:37:22

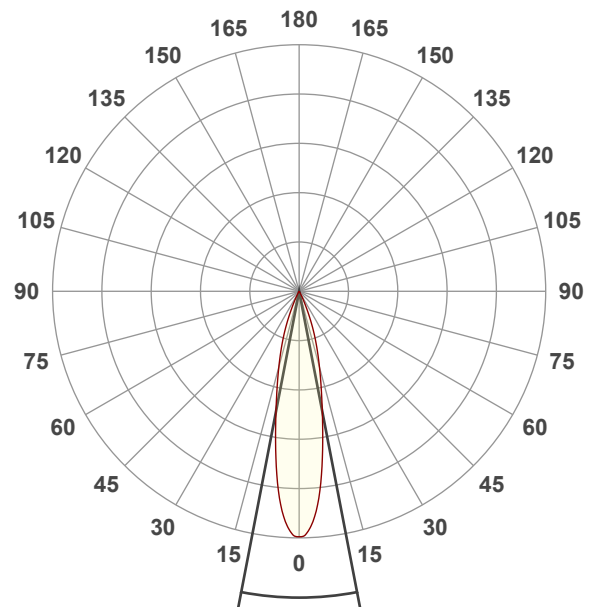

Spectra

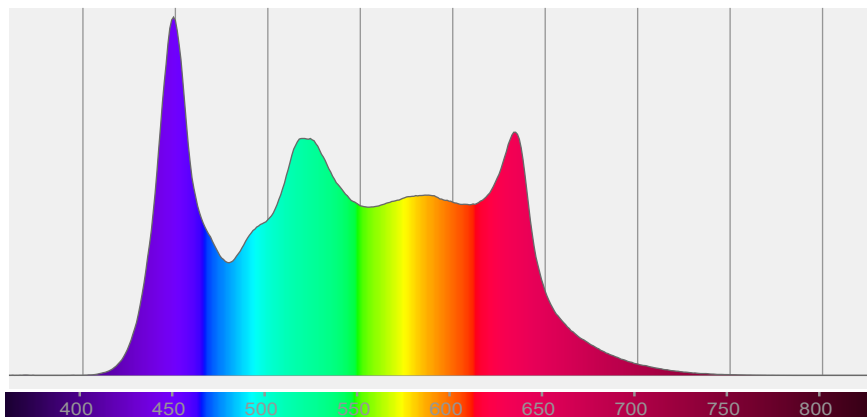

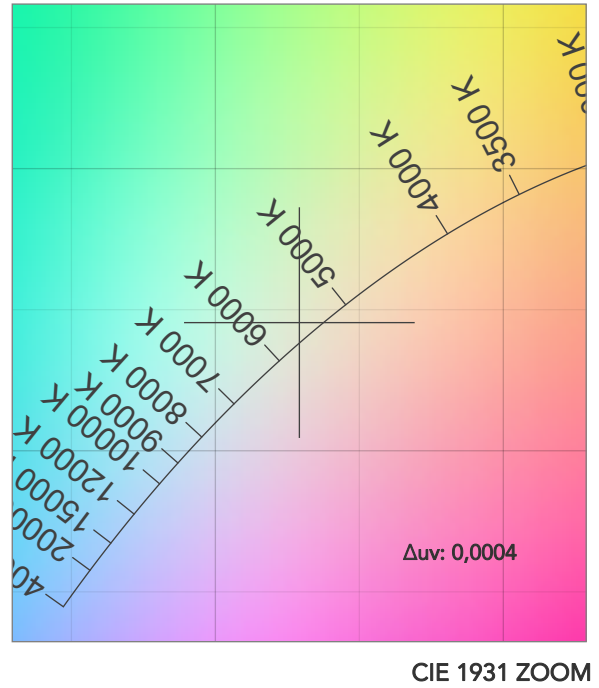
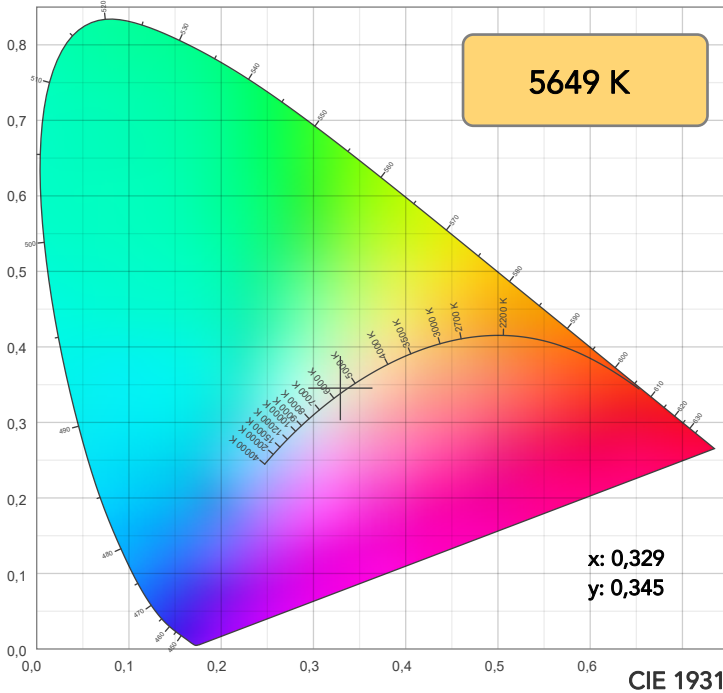

TM30: 93,7

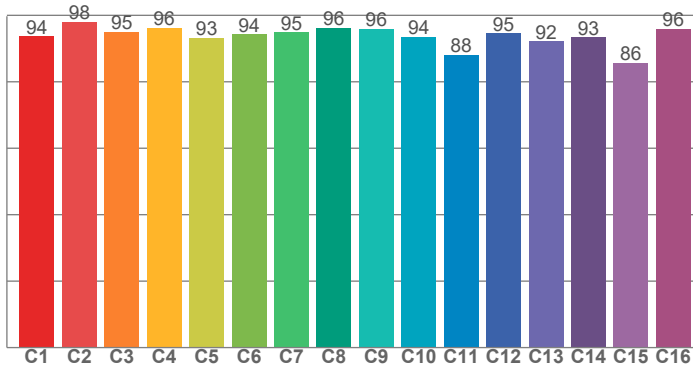

CRI: 96,1 (R1-R8)

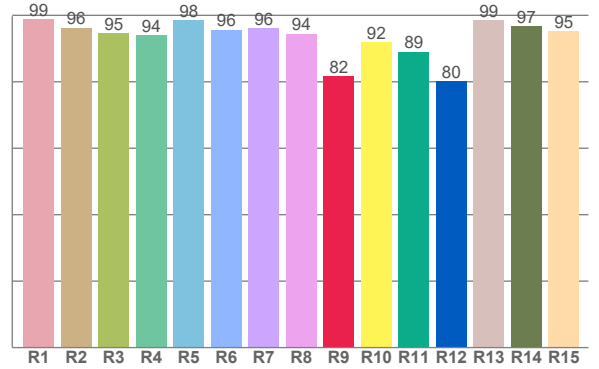

CRI R values, only R1-R8 are used to calculate final CRI value

R1	R2	R3	R4	R5	R6	R7	R8	R9	R10	R11	R12	R13	R14	R15
98,9	96,3	94,7	94,0	98,5	95,6	96,2	94,5	81,7	91,9	89,1	80,1	98,6	96,6	95,3

TM30 C values, 16 binned values out of total of 99 C values

C1	C2	C3	C4	C5	C6	C7	C8	C9	C10	C11	C12	C13	C14	C15	C16
93,6	98,1	95,0	96,3	93,3	94,3	94,9	96,2	96,0	93,6	88,0	94,5	92,2	93,4	85,6	95,9

CQS Q values

Q1	Q2	Q3	Q4	Q5	Q6	Q7	Q8	Q9	Q10	Q11	Q12	Q13	Q14	Q15
94,7	99,1	89,7	94,3	97,5	94,4	96,2	99,2	97,8	95,9	98,9	99,1	99,4	94,7	94,4

CQS: 95,5

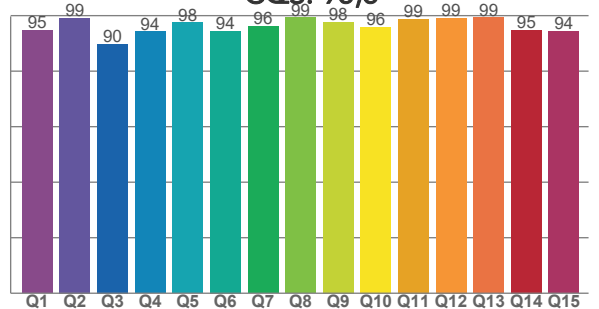

COLOR PARAMETERS

Color temperature	Color rendering index	Red component	Color fidelity	Color gamut	Color quality scale	Television lighting index	Color coordinate cie 1931	Color coordinate cie 1931	Color deviation from black body
CCT	CRI	CRI R9	TM30 Rf	TM30 Rg	CQS	TLCI	x	y	Δuv
5649 K	96,1	81,7	93,7	102,0	95,5	93	0,329	0,345	0,0004

# TM30 DETAILS

**Rf 93,7**  
Fidelity index Rf

**Rg 102,0**  
Gammut index

Hue Bin	R <sub>f</sub>	Graphic shifts (%)	
		Chroma	Hue
1	94	-2%	-1%
2	98	-1%	1%
3	95	-1%	2%
4	96	-1%	1%
5	93	-1%	1%
6	94	3%	2%
7	95	2%	0%
8	96	0%	0%
9	96	-1%	2%
10	94	-1%	4%
11	88	2%	7%
12	95	3%	0%
13	92	5%	-4%
14	93	3%	-2%
15	86	7%	-11%
16	96	0%	-2%

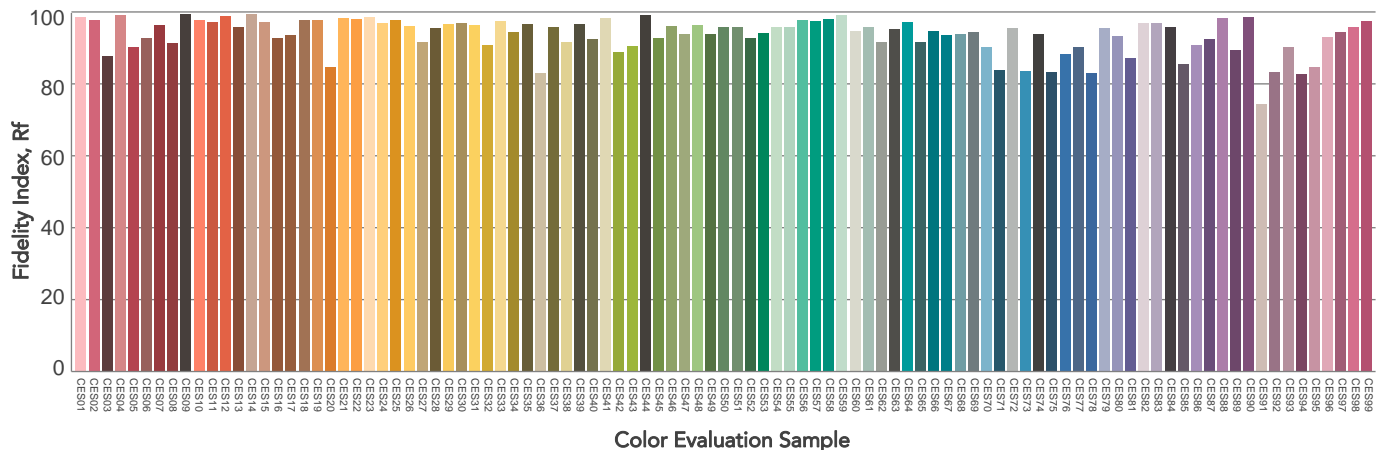
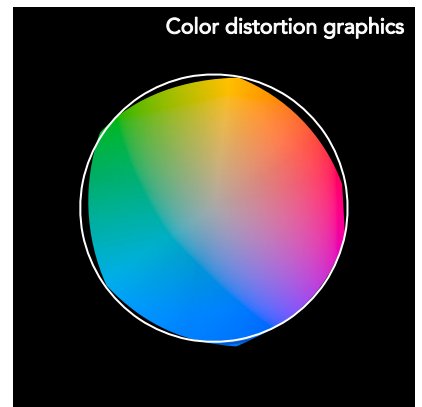
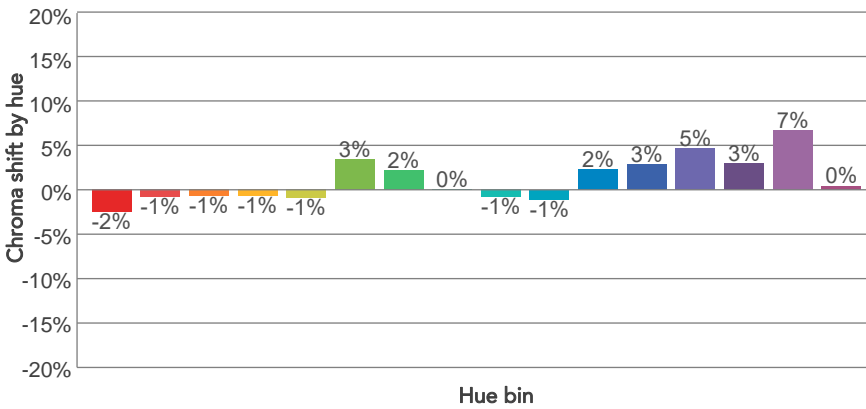
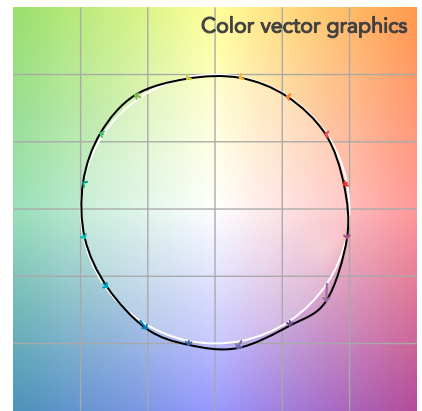
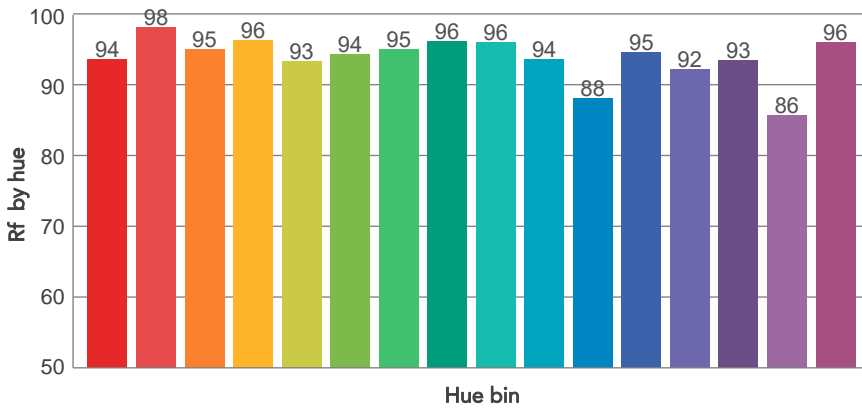
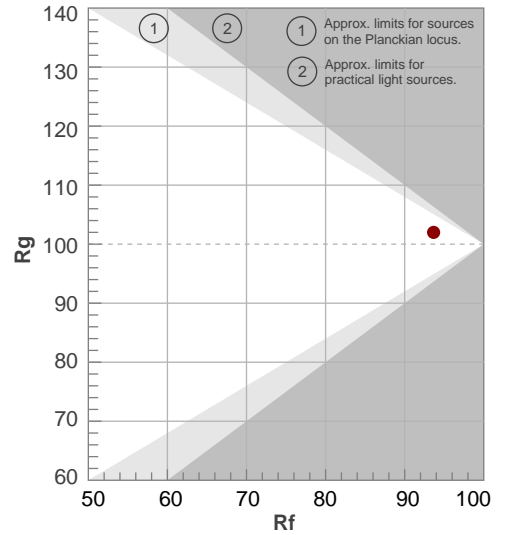



# BEAM DETAILS



Beam angle 50%	Field angle 10%	Cut off angle 2,5%	Intensity ratio in 120° cone	Intensity ratio in 90° cone
21,8°	45,1°	54,2°	100,0%	100,0%

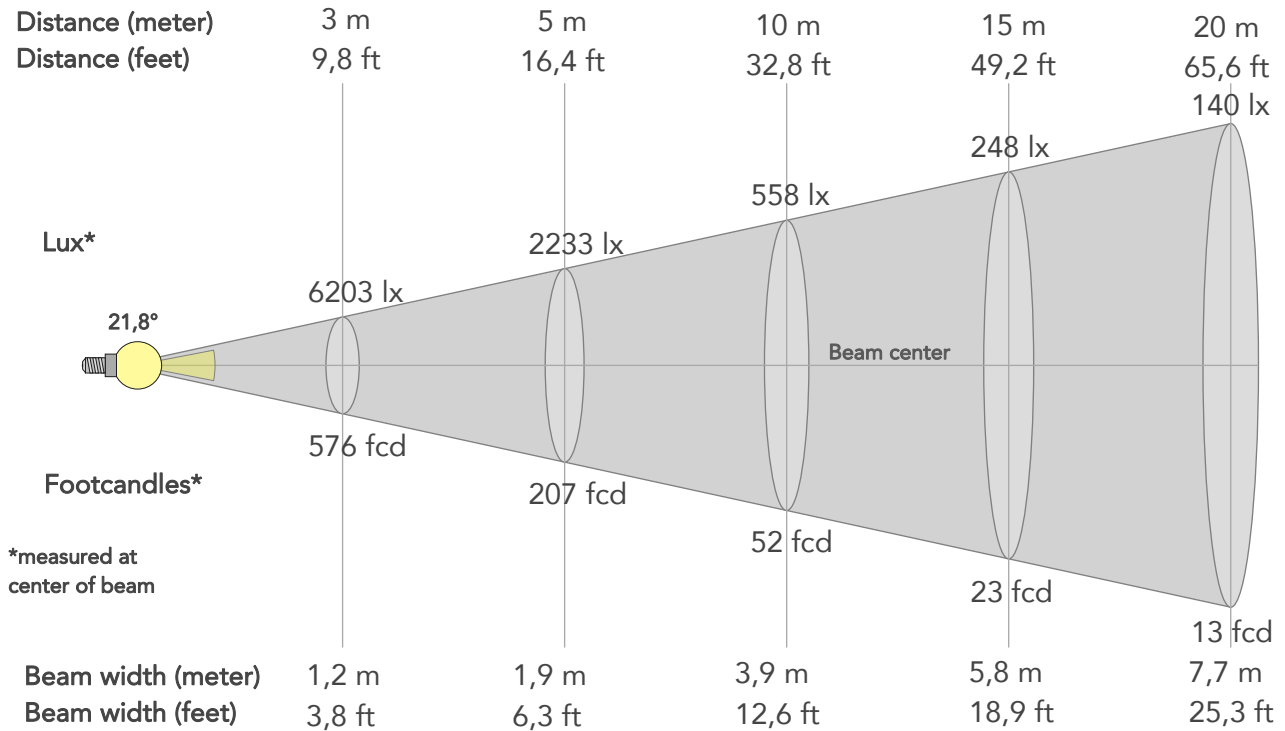

## BEAM INTENSITIES AND WIDTHS

Distance	1m	2m	3m	4m	5m	7,5m	10m	15m	20m	25m	30m	40m	50m
Distance	3,3ft	6,6ft	9,8ft	13,1ft	16,4ft	24,6ft	32,8ft	49,2ft	65,6ft	82ft	98,4ft	131,2ft	164ft
Lux	55829lx	13957lx	6203lx	3489lx	2233lx	993lx	558lx	248lx	140lx	89lx	62lx	35lx	22lx
Footcand.	5187fcd	1297fcd	576fcd	324fcd	207fcd	92fcd	52fcd	23fcd	13fcd	8fcd	6fcd	3fcd	2fcd
Beam wid.	0,4m	0,8m	1,2m	1,5m	1,9m	2,9m	3,9m	5,8m	7,7m	9,6m	11,6m	15,4m	19,3m
Beam wid.	1,3ft	2,5ft	3,8ft	5ft	6,3ft	9,5ft	12,6ft	18,9ft	25,3ft	31,6ft	37,9ft	50,5ft	63,2ft

## LINEAR DISTRIBUTION DIAGRAM

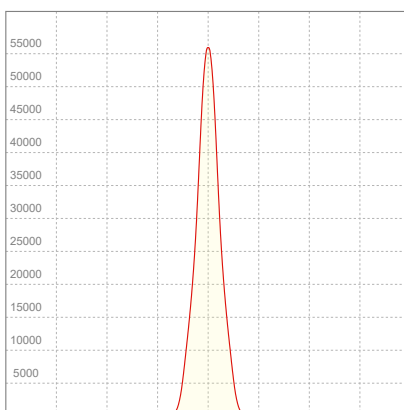

## ELECTRICAL SPECIFICATIONS

Input voltage	Input current	Input power	Effeciency
224V	2,29A	510,9W	21lm/W

## ISO CANDELA DIAGRAM

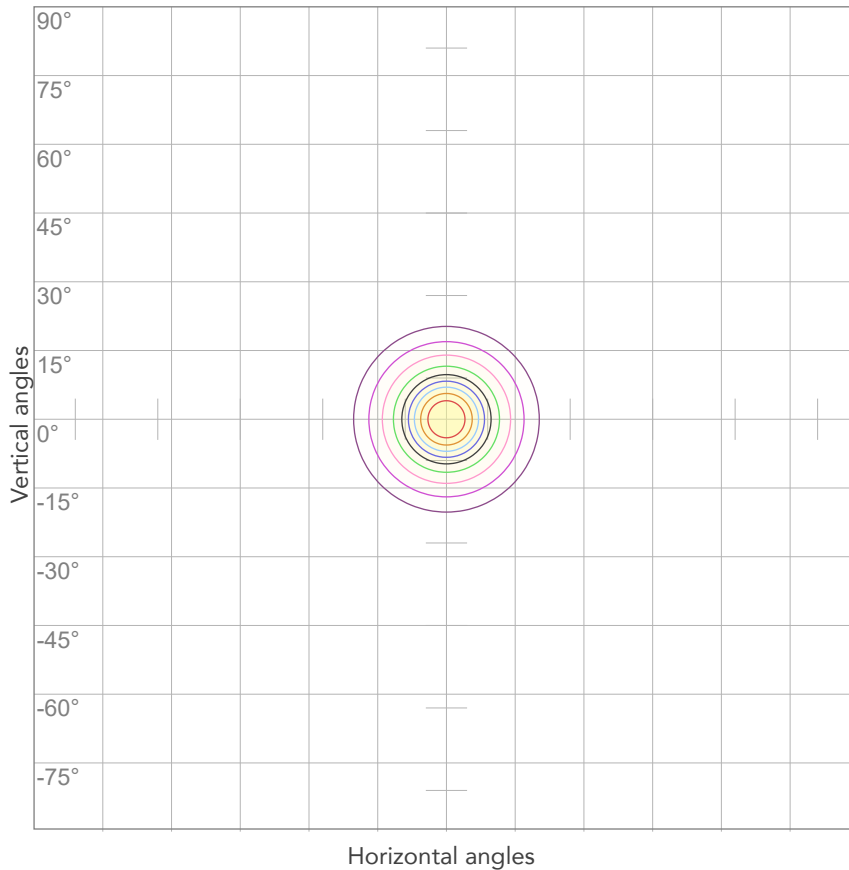

10%	5583 cd
20%	11166 cd
30%	16749 cd
40%	22332 cd
50%	27914 cd
60%	33497 cd
70%	39080 cd
80%	44663 cd

Conditions:

Number of c-planes: 2

Candela at center: 55829 cd

## ISO LUX DIAGRAM

MH: 10,0 m

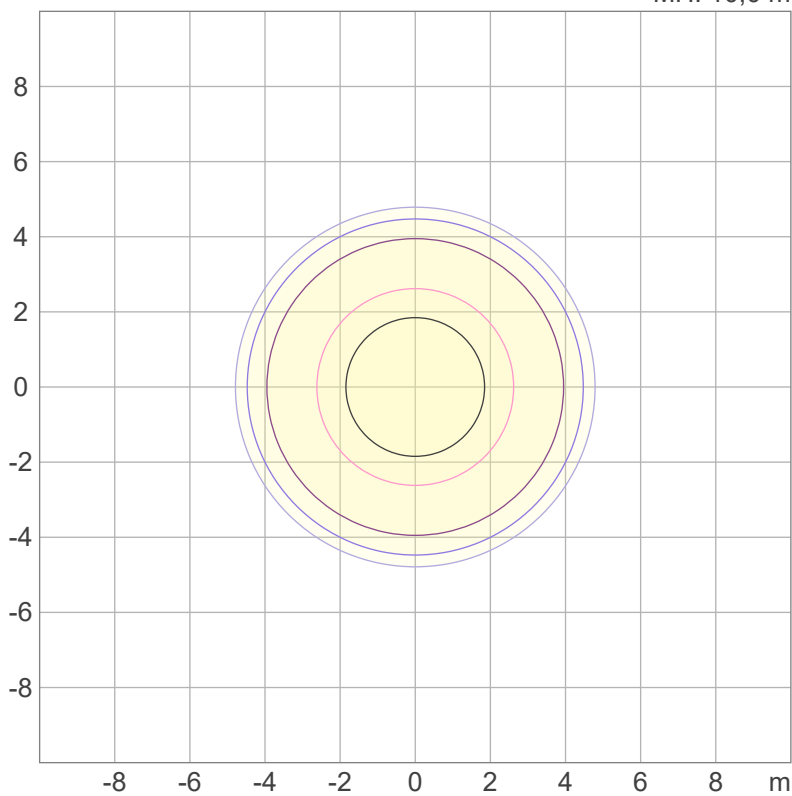

Mounting height: 10 meters (33 feet)

3%	16,7 lx
5%	27,9 lx
10%	55,8 lx
30%	167 lx
50%	279 lx

Conditions:

Number of c-planes: 2

Lux at center: 558 lx

*Lux distribution on a surface when lamp is mounted at 10 meters from the surface.*



Total lumen output:

5742 lm

Peak candela output:

149630 cd

Light quality:

CRI: 96,0

Color temperature:

5648 K

**PRODUCT NAME:**  
**ECLFRCTPLIP**

**MEASURAMENT CONDITIONS:**

Beam angle:

Min Zoom

Target:

5600K - HB

Operator:

Salvatore Giglio

Date and time:

03/10/2023 14:07:53

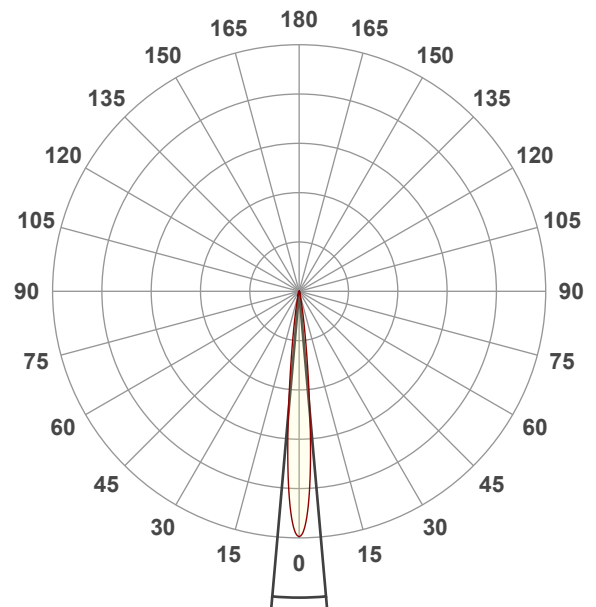

Beam angle 50%: 10,1°

Field angle 10%: 18,7°

Cut off angle 2.5%: 26,2°

Spectra

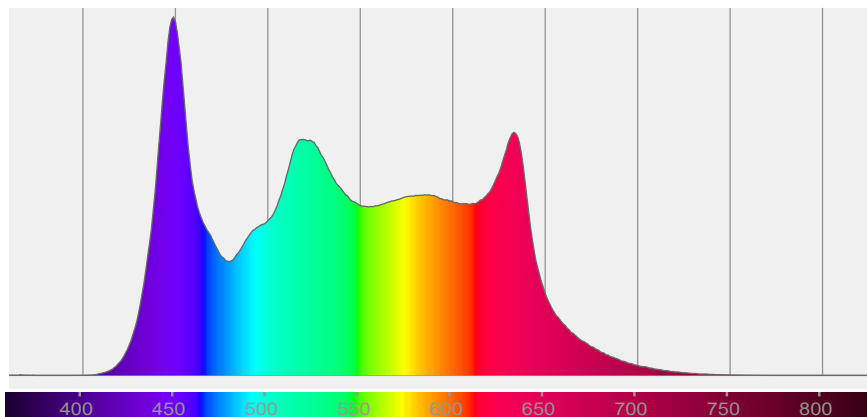

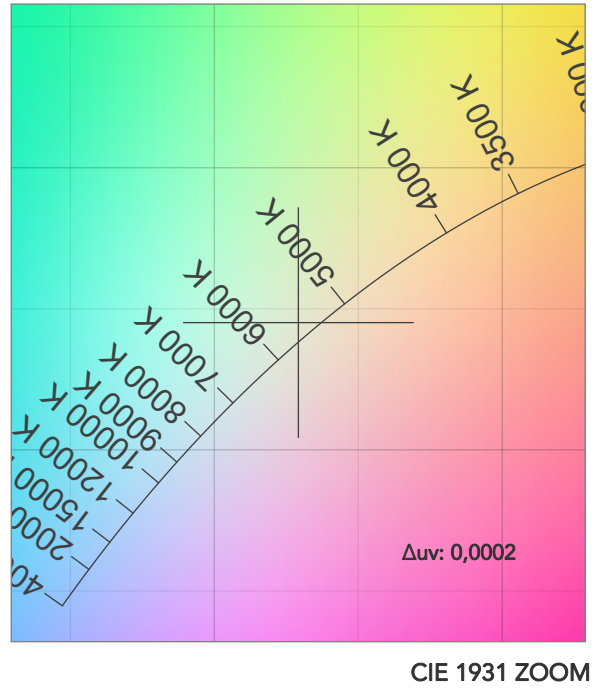
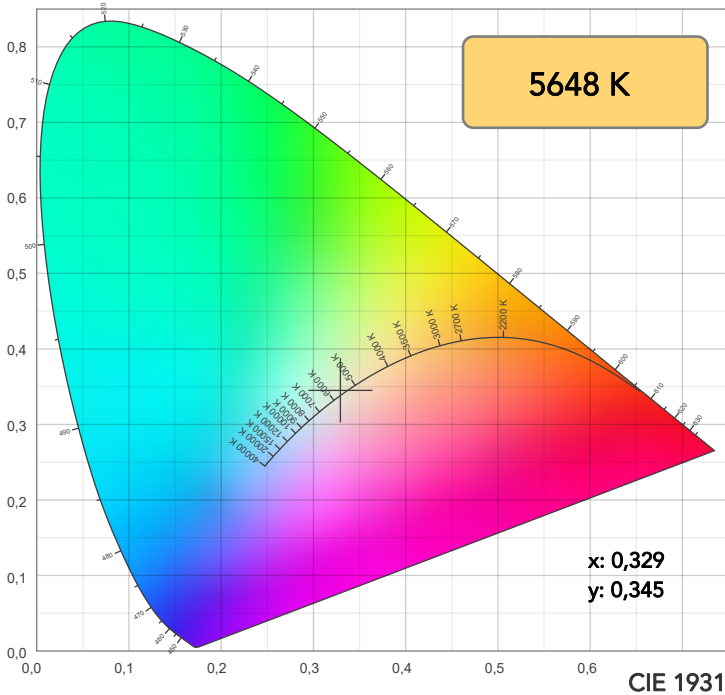

TM30: 93,6

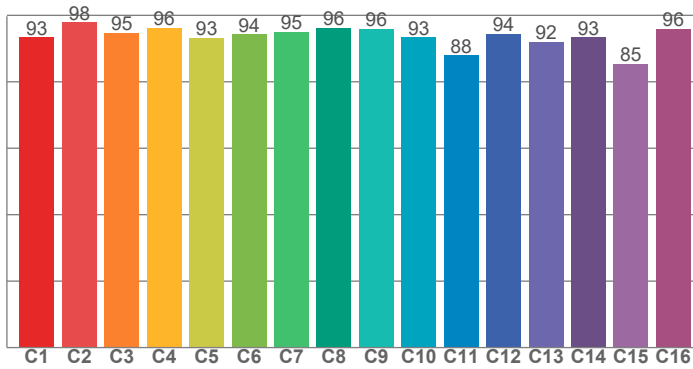

CRI: 96,0 (R1-R8)

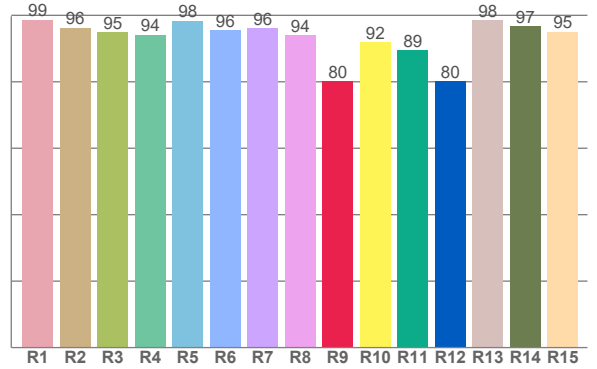

CQS: 95,3

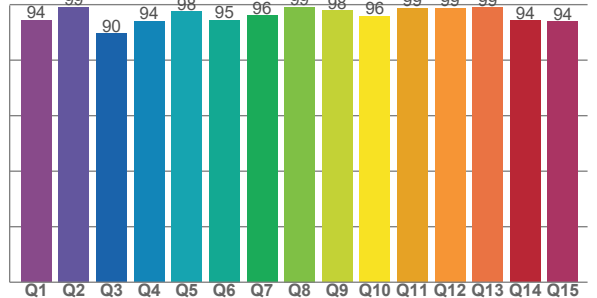

CRI R values, only R1-R8 are used to calculate final CRI value

R1	R2	R3	R4	R5	R6	R7	R8	R9	R10	R11	R12	R13	R14	R15
98,7	96,3	94,8	94,2	98,4	95,6	96,1	93,9	80,2	91,9	89,4	80,2	98,5	96,7	95,0

TM30 C values, 16 binned values out of total of 99 C values

C1	C2	C3	C4	C5	C6	C7	C8	C9	C10	C11	C12	C13	C14	C15	C16
93,4	97,9	94,7	96,2	93,2	94,3	95,0	96,2	95,9	93,4	87,9	94,4	92,0	93,3	85,4	95,9

CQS Q values

Q1	Q2	Q3	Q4	Q5	Q6	Q7	Q8	Q9	Q10	Q11	Q12	Q13	Q14	Q15
94,4	99,1	89,6	94,0	97,5	94,5	96,1	99,2	97,8	95,8	98,7	98,8	99,0	94,2	93,9

COLOR PARAMETERS

Color temperature	Color rendering index	Red component	Color fidelity	Color gamut	Color quality scale	Television lighting index	Color coordinate cie 1931	Color coordinate cie 1931	Color deviation from black body
CCT	CRI	CRI R9	TM30 Rf	TM30 Rg	CQS	TLCI	x	y	Δuv
5648 K	96,0	80,2	93,6	101,9	95,3	93	0,329	0,345	0,0002

# TM30 DETAILS

**Rf 93,6**  
Fidelity index Rf

**Rg 101,9**  
Gammut index

Hue Bin	R <sub>f</sub>	Graphic shifts (%)	
		Chroma	Hue
1	93	-3%	-1%
2	98	-1%	1%
3	95	-1%	2%
4	96	-1%	1%
5	93	-1%	1%
6	94	3%	2%
7	95	2%	0%
8	96	0%	0%
9	96	-1%	2%
10	93	-1%	4%
11	88	2%	7%
12	94	3%	0%
13	92	5%	-4%
14	93	3%	-2%
15	85	7%	-11%
16	96	0%	-2%

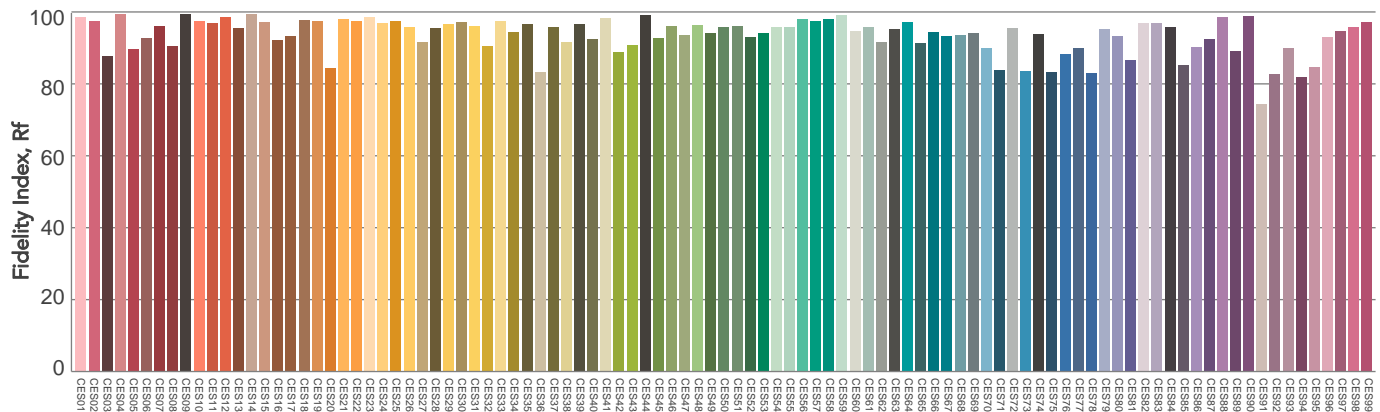
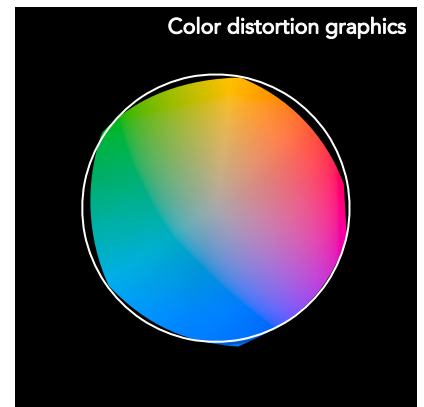
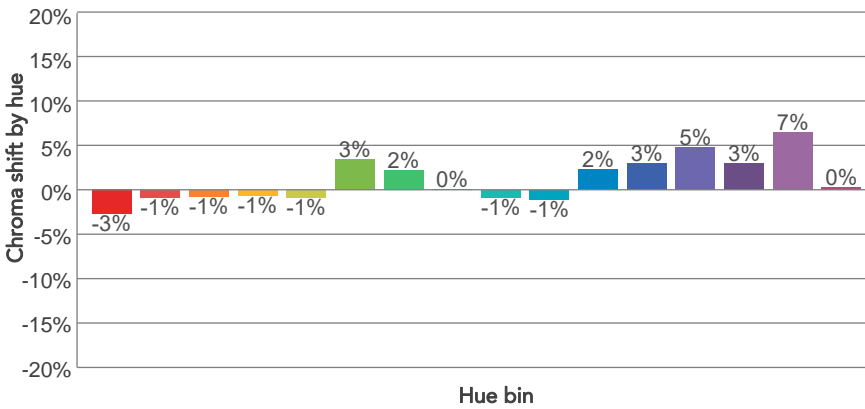
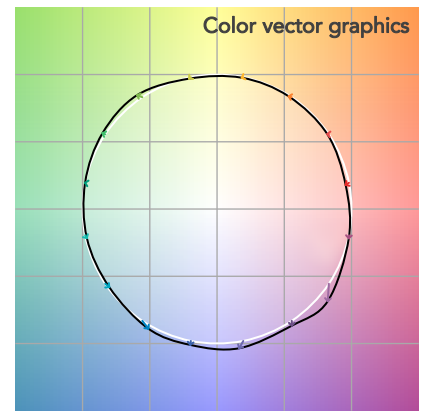
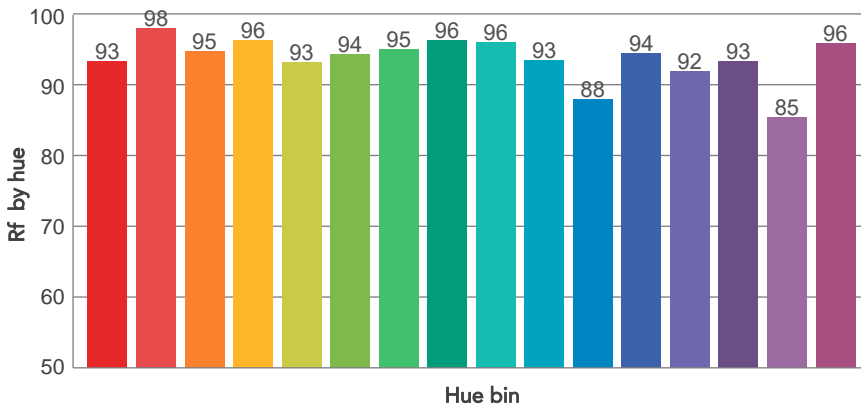
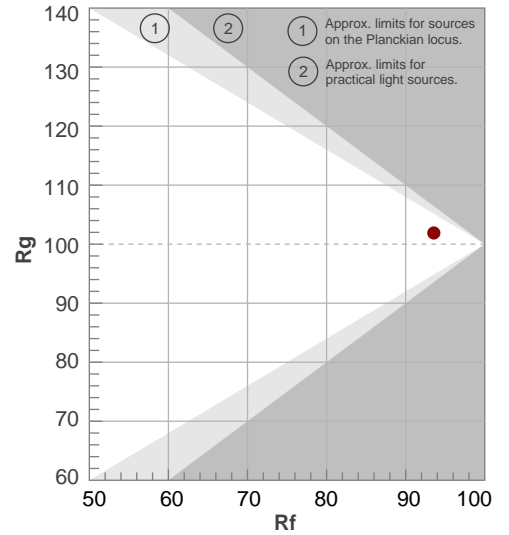

Color Evaluation Sample

# BEAM DETAILS



Beam angle 50%	Field angle 10%	Cut off angle 2,5%	Intensity ratio in 120° cone	Intensity ratio in 90° cone
10,1°	18,7°	26,2°	100,0%	100,0%

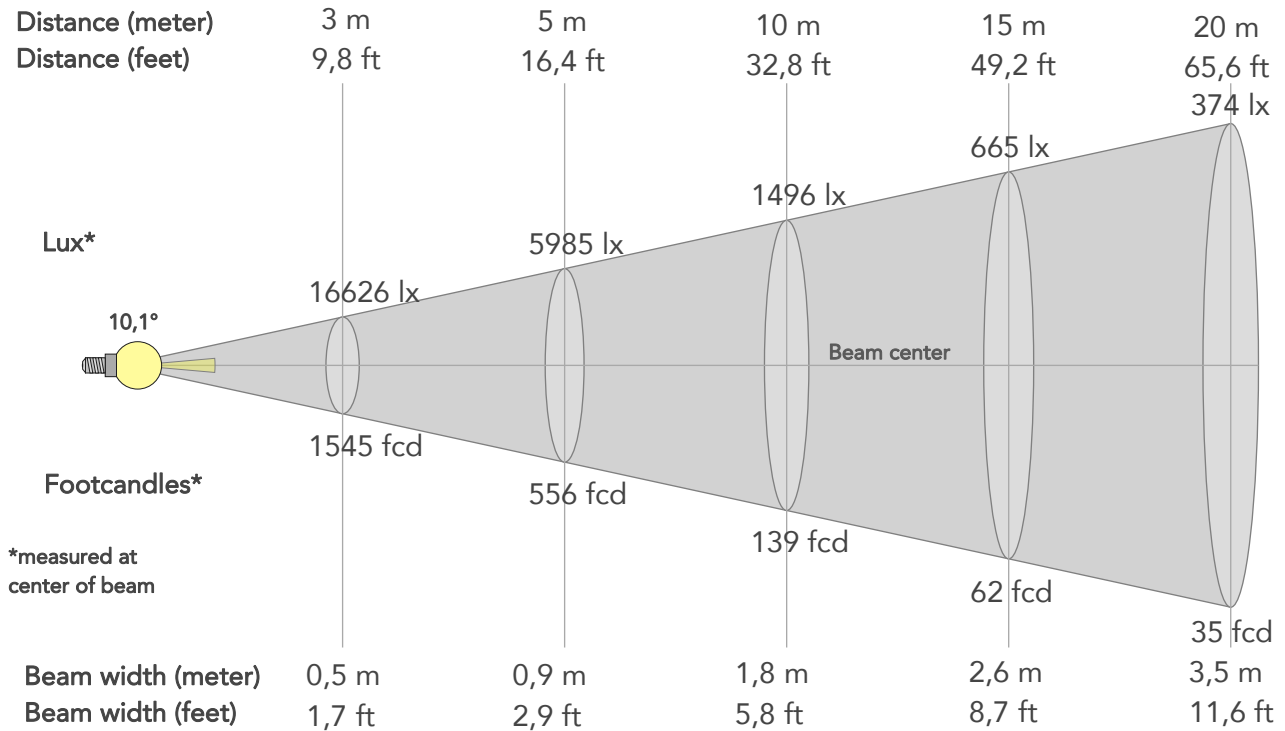

## BEAM INTENSITIES AND WIDTHS

Distance	1m	2m	3m	4m	5m	7,5m	10m	15m	20m	25m	30m	40m	50m
Distance	3,3ft	6,6ft	9,8ft	13,1ft	16,4ft	24,6ft	32,8ft	49,2ft	65,6ft	82ft	98,4ft	131,2ft	164ft
Lux	149630lx	37408lx	16626lx	9352lx	5985lx	2660lx	1496lx	665lx	374lx	239lx	166lx	94lx	60lx
Footcand.	13901fcd	3475fcd	1545fcd	869fcd	556fcd	247fcd	139fcd	62fcd	35fcd	22fcd	15fcd	9fcd	6fcd
Beam wid.	0,2m	0,4m	0,5m	0,7m	0,9m	1,3m	1,8m	2,6m	3,5m	4,4m	5,3m	7m	8,8m
Beam wid.	0,6ft	1,2ft	1,7ft	2,3ft	2,9ft	4,3ft	5,8ft	8,7ft	11,6ft	14,4ft	17,3ft	23,1ft	28,9ft

## LINEAR DISTRIBUTION DIAGRAM

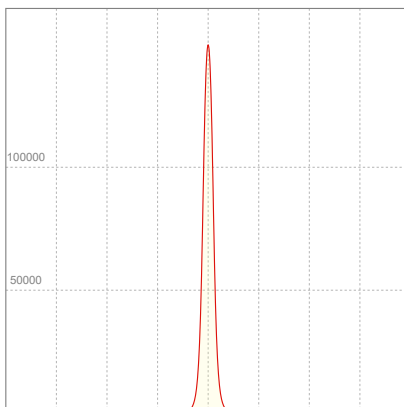

## ELECTRICAL SPECIFICATIONS

Input voltage	Input current	Input power	Effeciency
226V	2,27A	510,5W	11lm/W

## ISO CANDELA DIAGRAM

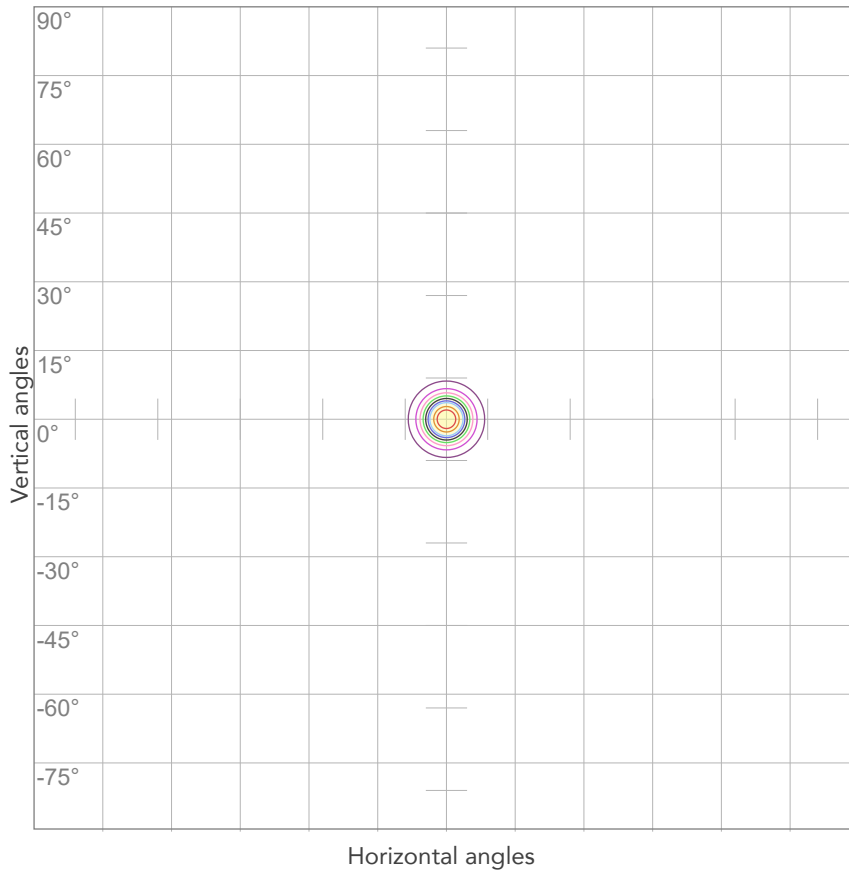

10%	14963 cd
20%	29926 cd
30%	44889 cd
40%	59852 cd
50%	74815 cd
60%	89778 cd
70%	104741 cd
80%	119704 cd

Conditions:

Number of c-planes: 2

Candela at center: 149630 cd

## ISO LUX DIAGRAM

MH: 10,0 m

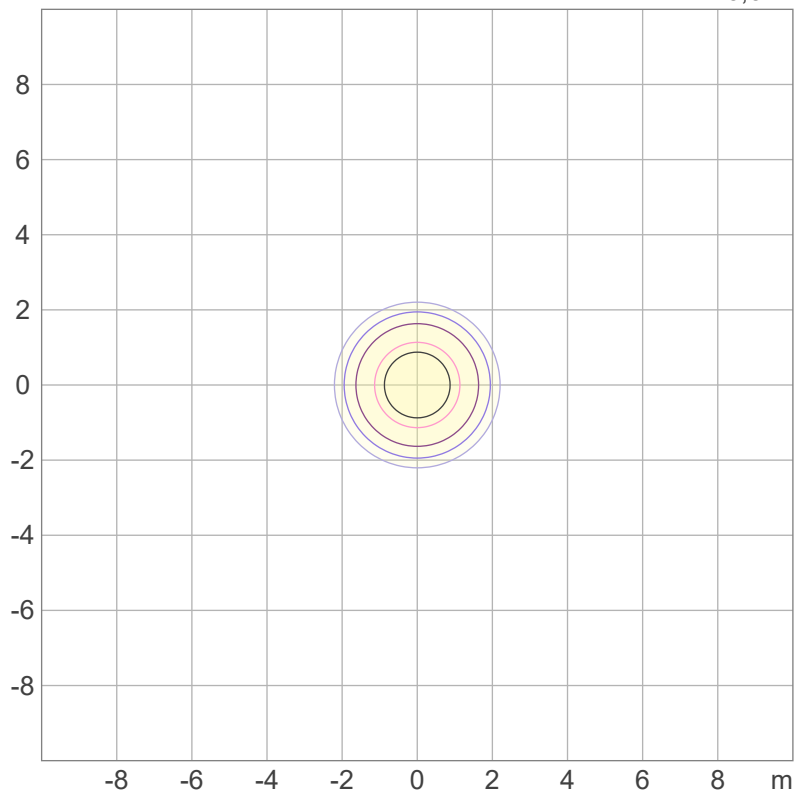

Mounting height: 10 meters (33 feet)

3%	44,9 lx
5%	74,8 lx
10%	150 lx
30%	449 lx
50%	748 lx

Conditions:

Number of c-planes: 2

Lux at center: 1496 lx

*Lux distribution on a surface when lamp is mounted at 10 meters from the surface.*



Total lumen output:

11964 lm

Peak candela output:

15365 cd

Light quality:

CRI: 94,2

Color temperature:

6009 K

**PRODUCT NAME:**

**ECLFRCTPLIP**

**MEASURAMENT CONDITIONS:**

Beam angle:

Max Zoom

Target:

6000K - HB

Operator:

Salvatore Giglio

Date and time:

03/10/2023 13:07:50

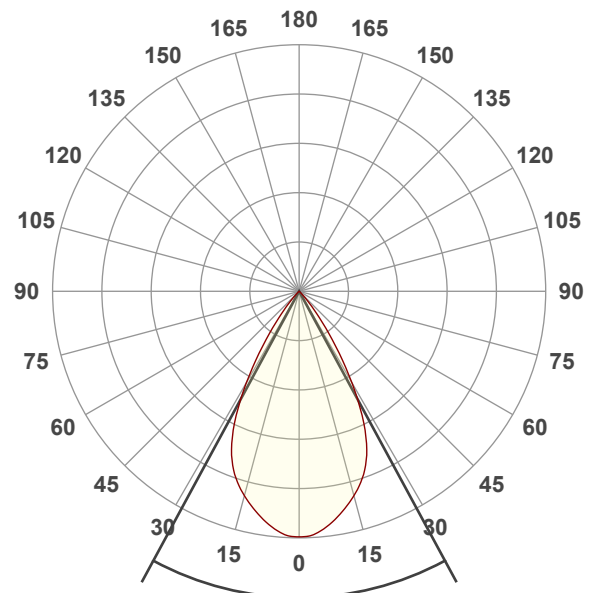

Beam angle 50%: 56,9°

Field angle 10%: 78°

Cut off angle 2.5%: 87,6°

Spectra

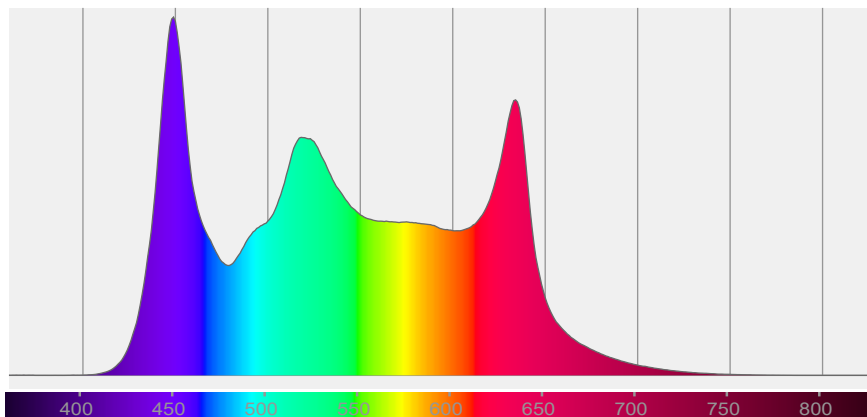



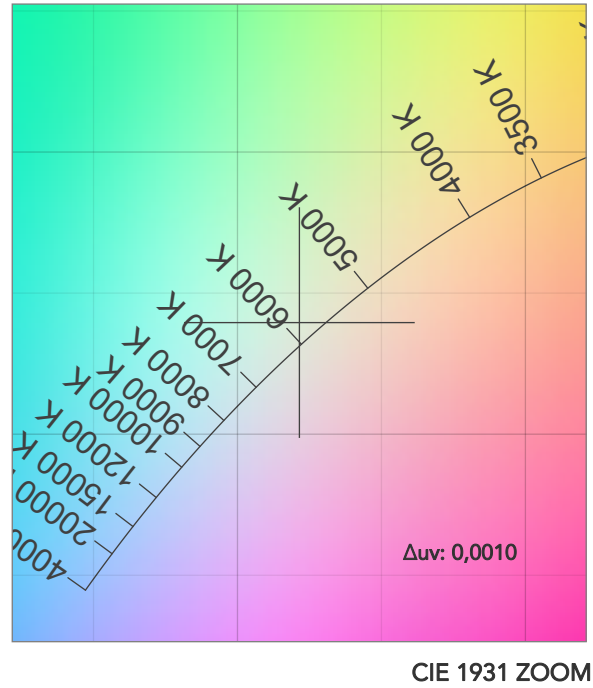
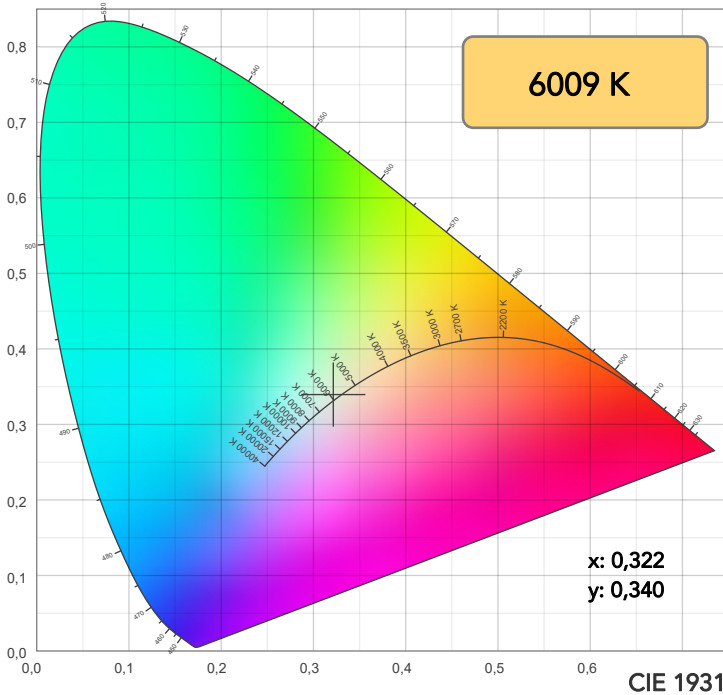

TM30: 93,7

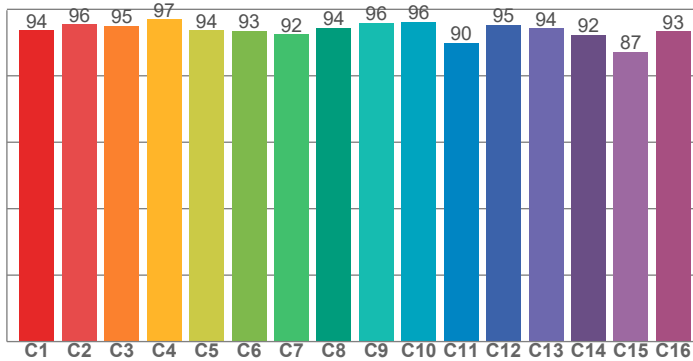

CRI: 94,2 (R1-R8)

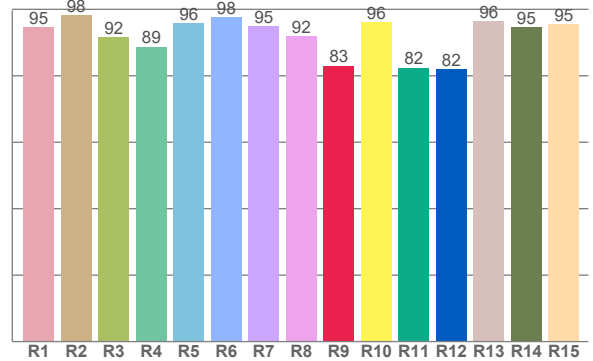

CRI R values, only R1-R8 are used to calculate final CRI value

R1	R2	R3	R4	R5	R6	R7	R8	R9	R10	R11	R12	R13	R14	R15
94,6	98,3	91,6	88,8	95,9	97,6	95,0	91,8	83,0	96,1	82,4	82,0	96,3	94,6	95,5

TM30 C values, 16 binned values out of total of 99 C values

C1	C2	C3	C4	C5	C6	C7	C8	C9	C10	C11	C12	C13	C14	C15	C16
93,6	95,5	95,1	97,0	93,7	93,4	92,5	94,5	95,9	96,1	89,8	95,3	94,3	92,3	87,3	93,3

CQS Q values

Q1	Q2	Q3	Q4	Q5	Q6	Q7	Q8	Q9	Q10	Q11	Q12	Q13	Q14	Q15
98,7	99,2	92,0	98,3	94,5	93,1	97,5	96,2	95,9	98,2	95,3	93,9	94,1	97,8	97,8

CQS: 95,6

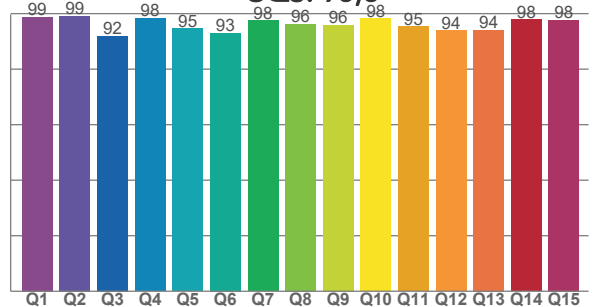

COLOR PARAMETERS

Color temperature	Color rendering index	Red component	Color fidelity	Color gamut	Color quality scale	Television lighting index	Color coordinate cie 1931	Color coordinate cie 1931	Color deviation from black body
CCT	CRI	CRI R9	TM30 Rf	TM30 Rg	CQS	TLCI	x	y	Δuv
6009 K	94,2	83,0	93,7	104,4	95,6	94	0,322	0,340	0,0010

# TM30 DETAILS

**Rf 93,7**  
Fidelity index Rf

**Rg 104,4**  
Gammut index

Hue Bin	R <sub>f</sub>	Graphic shifts (%)	
		Chroma	Hue
1	94	2%	-1%
2	96	2%	-2%
3	95	1%	-1%
4	97	-1%	-1%
5	94	-2%	1%
6	93	3%	3%
7	92	5%	1%
8	94	2%	0%
9	96	1%	1%
10	96	0%	2%
11	90	2%	6%
12	95	2%	1%
13	94	4%	-1%
14	92	3%	2%
15	87	10%	-5%
16	93	3%	-1%

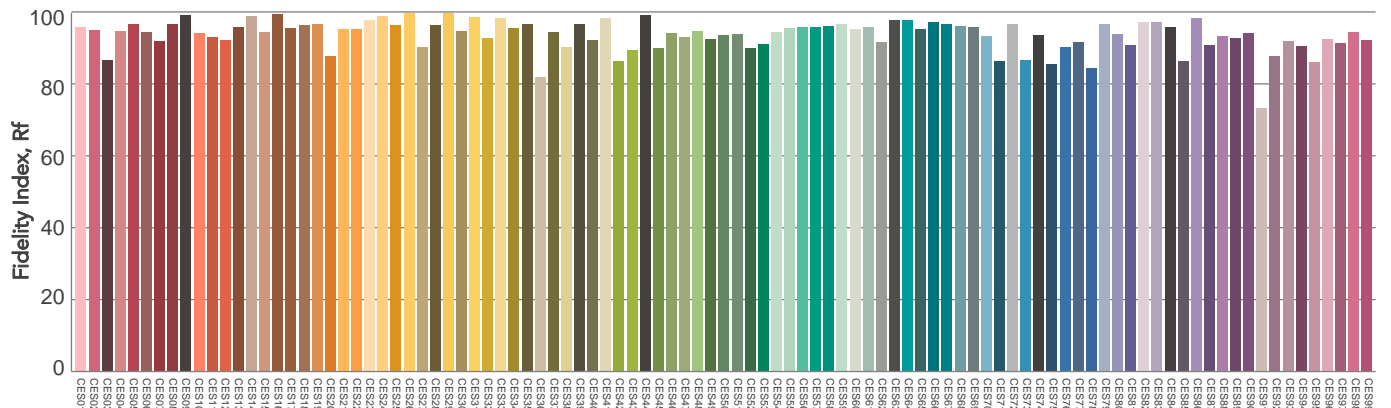
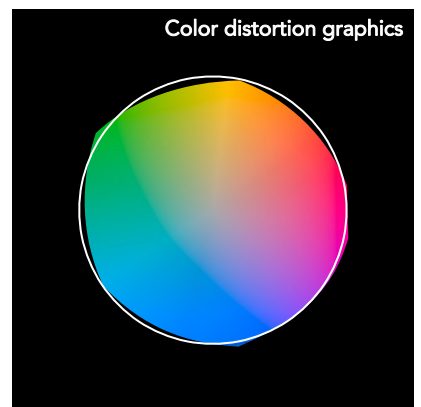
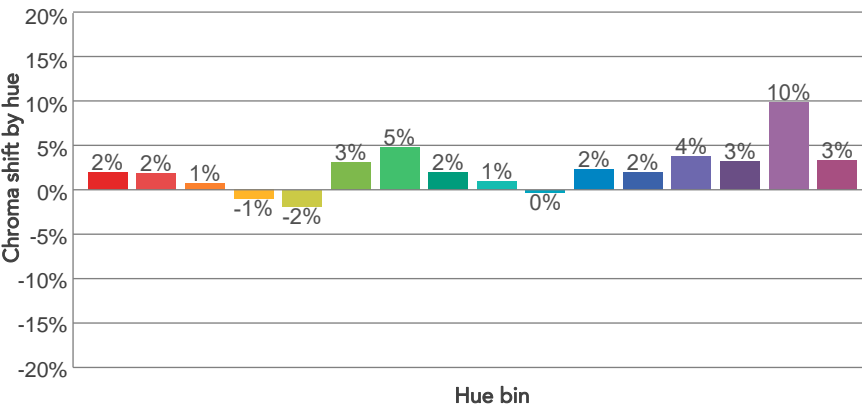
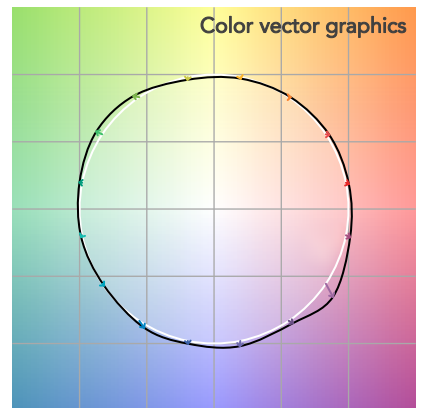
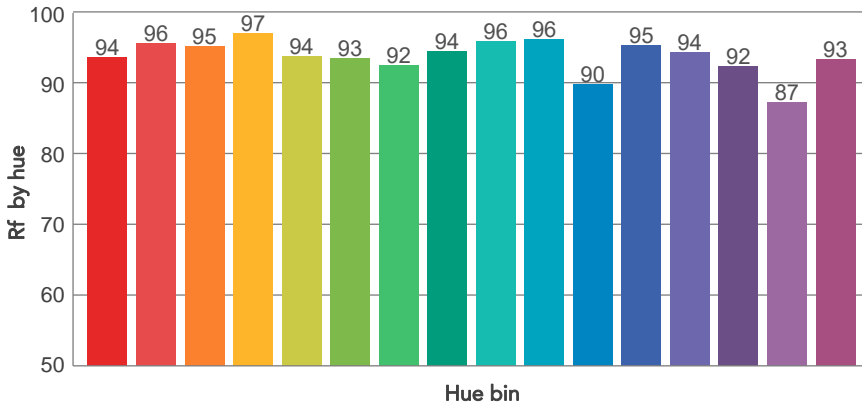
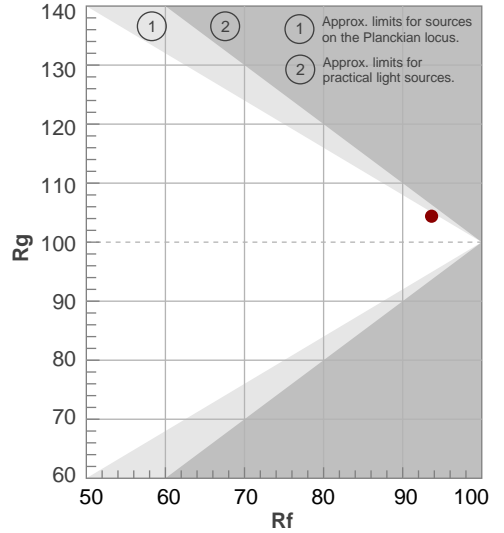

Color Evaluation Sample

# BEAM DETAILS



Beam angle 50%	Field angle 10%	Cut off angle 2,5%	Intensity ratio in 120° cone	Intensity ratio in 90° cone
56,9°	78°	87,6°	100,0%	99,4%

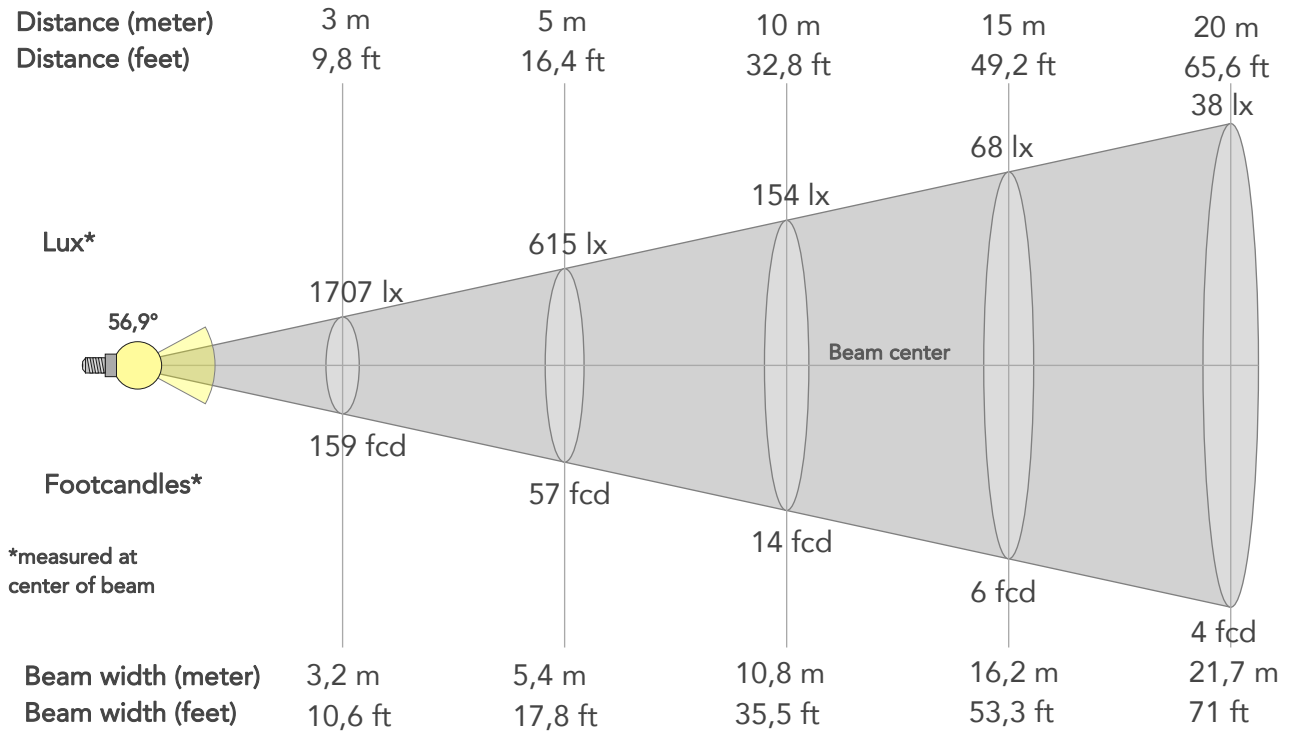

## BEAM INTENSITIES AND WIDTHS

Distance	1m	2m	3m	4m	5m	7,5m	10m	15m	20m	25m	30m	40m	50m
Distance	3,3ft	6,6ft	9,8ft	13,1ft	16,4ft	24,6ft	32,8ft	49,2ft	65,6ft	82ft	98,4ft	131,2ft	164ft
Lux	15365lx	3841lx	1707lx	960lx	615lx	273lx	154lx	68lx	38lx	25lx	17lx	10lx	6lx
Footcand.	1427fcd	357fcd	159fcd	89fcd	57fcd	25fcd	14fcd	6fcd	4fcd	2fcd	2fcd	1fcd	1fcd
Beam wid.	1,1m	2,2m	3,2m	4,3m	5,4m	8,1m	10,8m	16,2m	21,7m	27,1m	32,5m	43,3m	54,1m
Beam wid.	3,6ft	7,1ft	10,6ft	14,2ft	17,8ft	26,6ft	35,5ft	53,3ft	71ft	88,8ft	106,5ft	142ft	177,5ft

## LINEAR DISTRIBUTION DIAGRAM

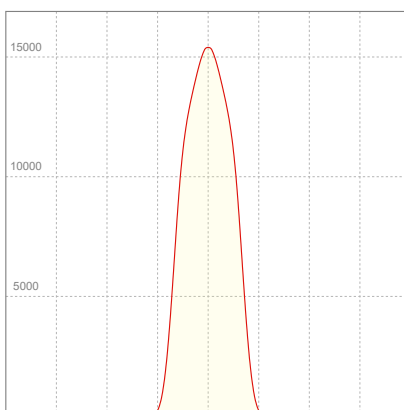

## ELECTRICAL SPECIFICATIONS

Input voltage	Input current	Input power	Effeciency
227V	2,13A	481,9W	25lm/W

## ISO CANDELA DIAGRAM

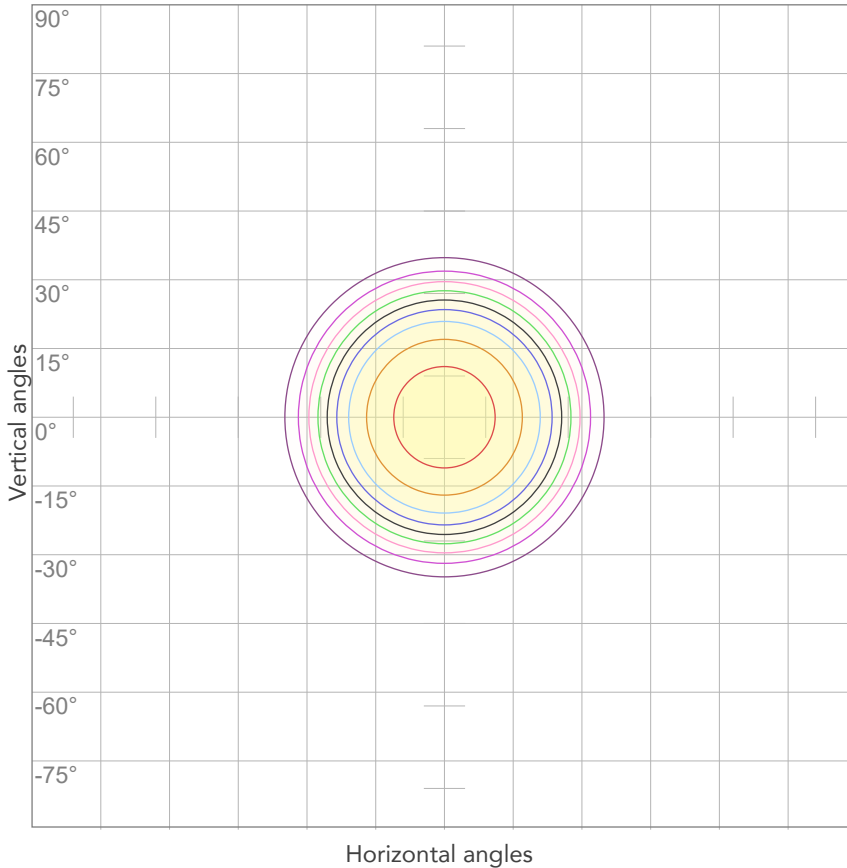

10%	1537 cd
20%	3073 cd
30%	4610 cd
40%	6146 cd
50%	7683 cd
60%	9219 cd
70%	10756 cd
80%	12292 cd

Conditions:

Number of c-planes: 2

Candela at center: 15365 cd

## ISO LUX DIAGRAM

MH: 10,0 m

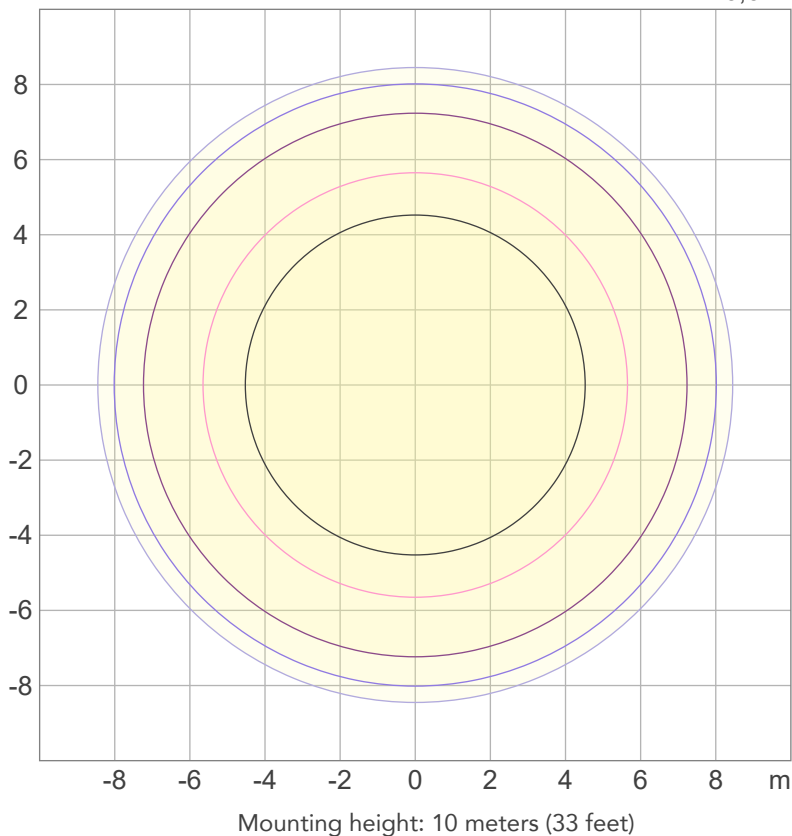

3%	4,61 lx
5%	7,68 lx
10%	15,4 lx
30%	46,1 lx
50%	76,8 lx

Conditions:

Number of c-planes: 2

Lux at center: 154 lx

*Lux distribution on a surface when lamp is mounted at 10 meters from the surface.*



Total lumen output:

9999 lm

Peak candela output:

52474 cd

Light quality:

CRI: 94,4

Color temperature:

6068 K

**PRODUCT NAME:**

**ECLFRCTPLIP**

**MEASURAMENT CONDITIONS:**

Beam angle:

Med Zoom

Target:

6000K - HB

Operator:

Salvatore Giglio

Date and time:

03/10/2023 14:42:45

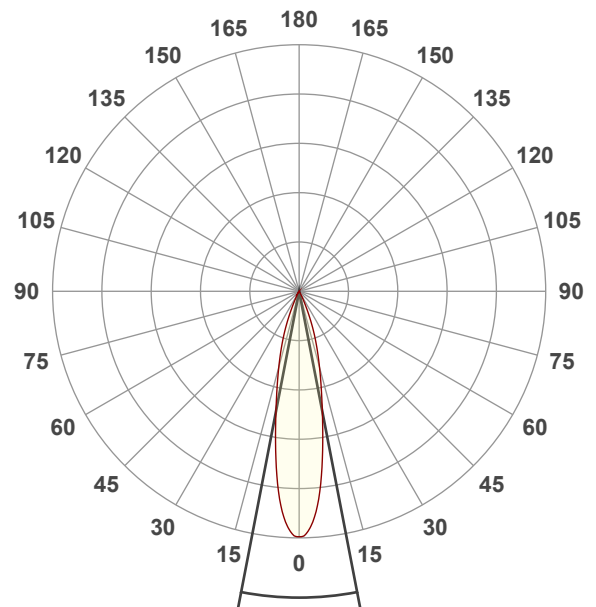

Spectra

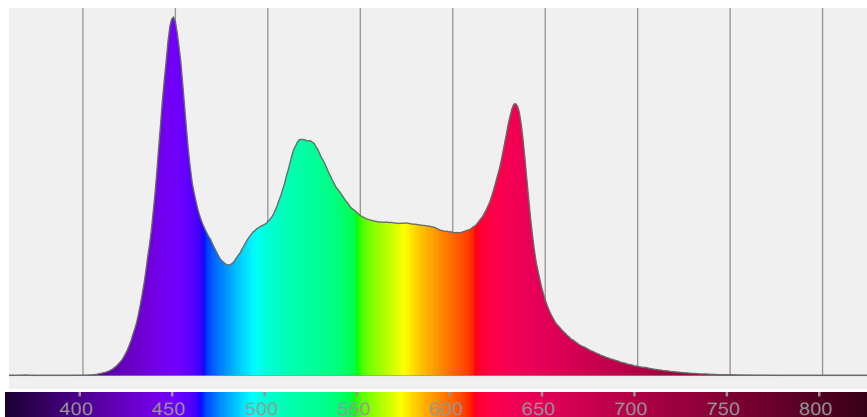

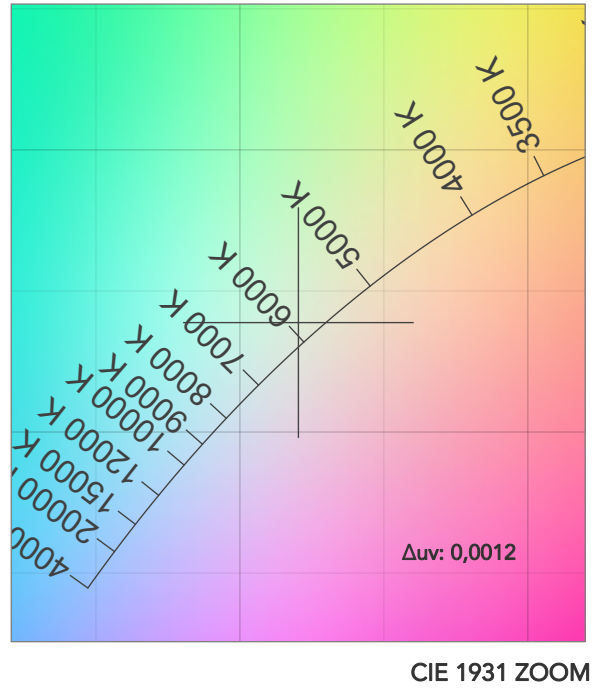
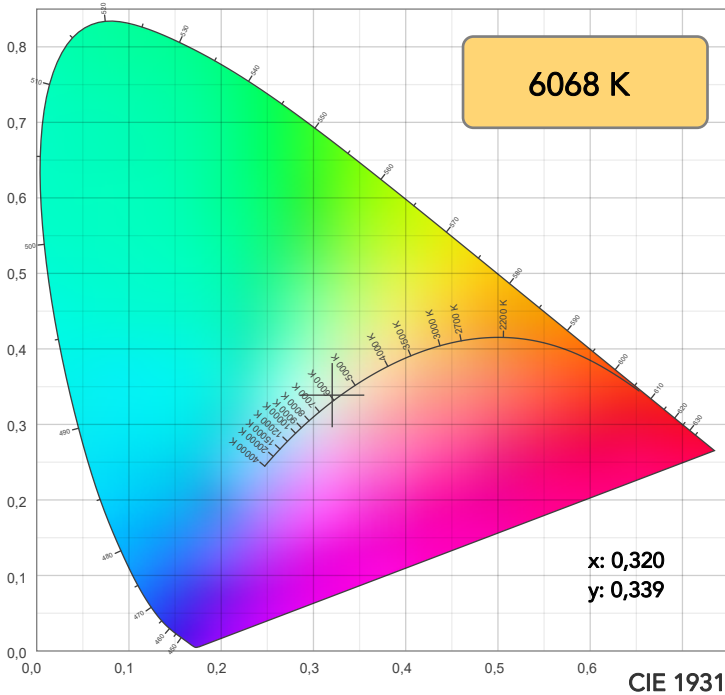

TM30: 93,7

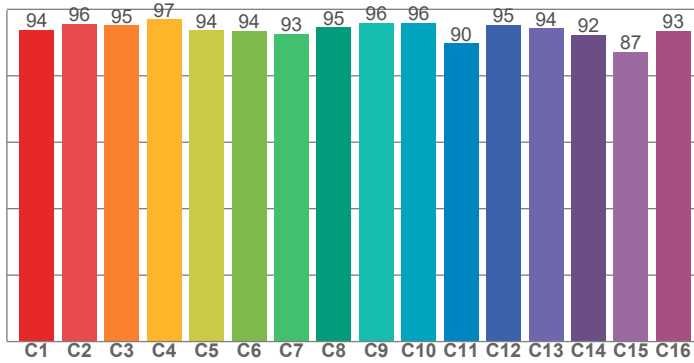

CRI: 94,4 (R1-R8)

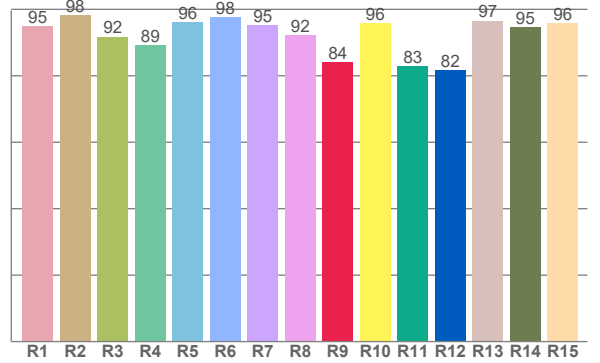

CRI R values, only R1-R8 are used to calculate final CRI value

R1	R2	R3	R4	R5	R6	R7	R8	R9	R10	R11	R12	R13	R14	R15
94,9	98,2	91,7	89,1	96,2	97,6	95,1	92,3	84,1	95,8	82,9	81,7	96,6	94,7	95,8

TM30 C values, 16 binned values out of total of 99 C values

C1	C2	C3	C4	C5	C6	C7	C8	C9	C10	C11	C12	C13	C14	C15	C16
93,8	95,6	95,1	97,0	93,6	93,6	92,7	94,6	95,9	96,0	89,7	95,3	94,2	92,4	87,2	93,5

CQS Q values

Q1	Q2	Q3	Q4	Q5	Q6	Q7	Q8	Q9	Q10	Q11	Q12	Q13	Q14	Q15
98,7	99,2	91,9	98,1	94,8	93,3	97,5	96,4	95,9	98,2	95,4	94,0	94,1	97,9	97,8

CQS: 95,7

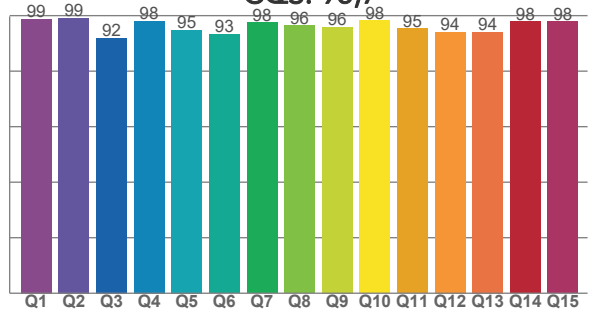

COLOR PARAMETERS

Color temperature	Color rendering index	Red component	Color fidelity	Color gamut	Color quality scale	Television lighting index	Color coordinate cie 1931	Color coordinate cie 1931	Color deviation from black body
CCT	CRI	CRI R9	TM30 Rf	TM30 Rg	CQS	TLCI	x	y	Δuv
6068 K	94,4	84,1	93,7	104,2	95,7	94	0,320	0,339	0,0012

# TM30 DETAILS

**Rf 93,7**  
Fidelity index Rf

**Rg 104,2**  
Gammut index

Hue Bin	R <sub>f</sub>	Graphic shifts (%)	
		Chroma	Hue
1	94	2%	-1%
2	96	2%	-2%
3	95	1%	-1%
4	97	-1%	-1%
5	94	-2%	1%
6	94	3%	3%
7	93	5%	1%
8	95	2%	0%
9	96	1%	1%
10	96	0%	2%
11	90	2%	6%
12	95	2%	1%
13	94	4%	-1%
14	92	3%	2%
15	87	10%	-5%
16	93	3%	-1%

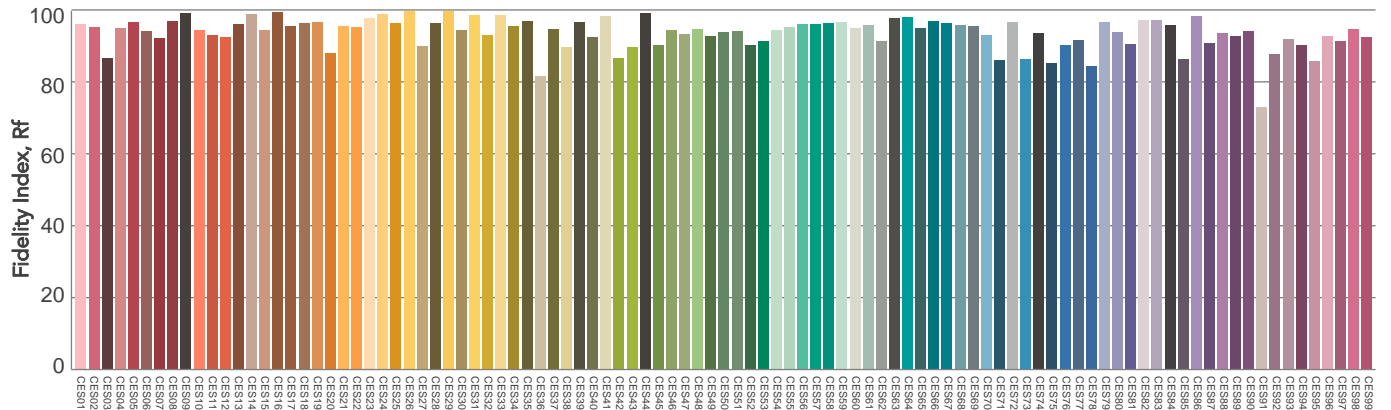
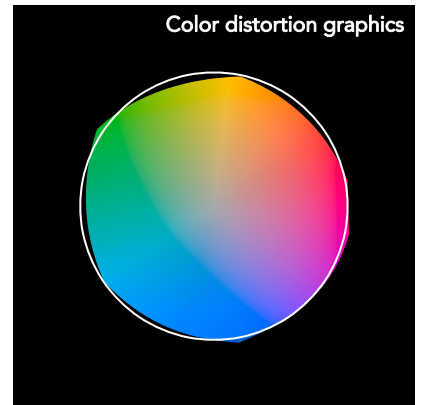
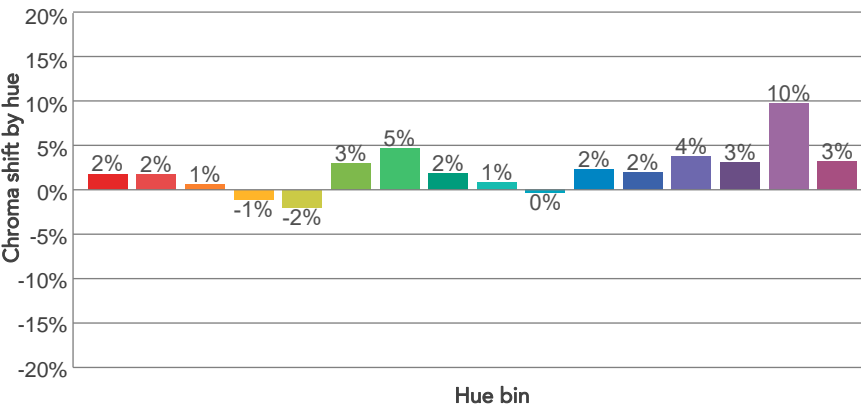
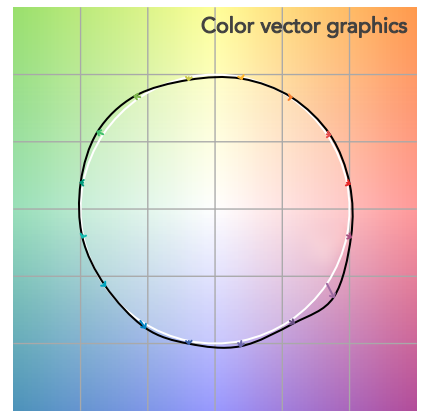
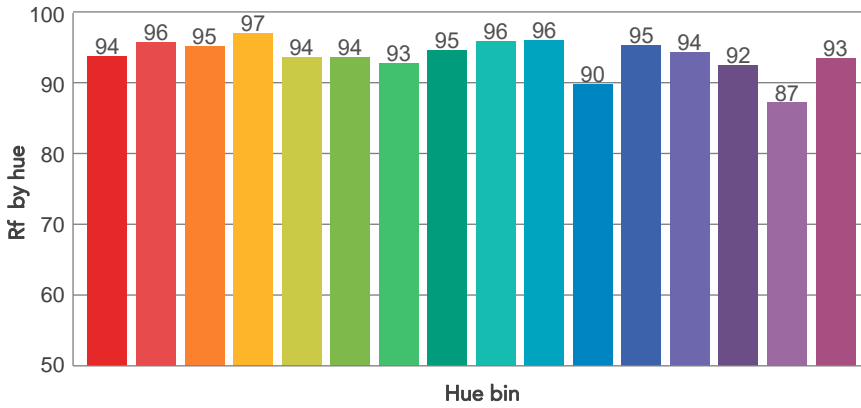
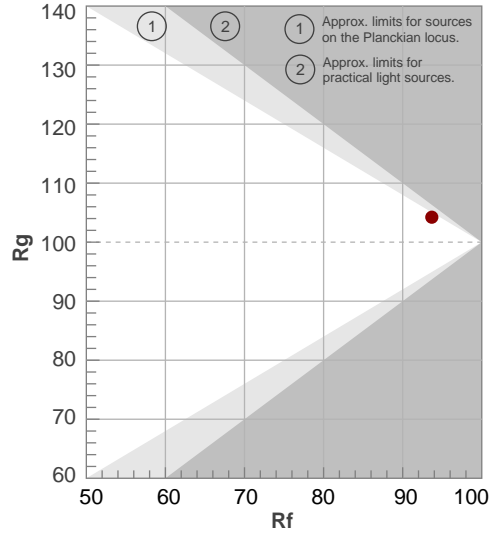

# BEAM DETAILS



Beam angle 50%	Field angle 10%	Cut off angle 2,5%	Intensity ratio in 120° cone	Intensity ratio in 90° cone
21,8°	45,1°	54,2°	100,0%	100,0%

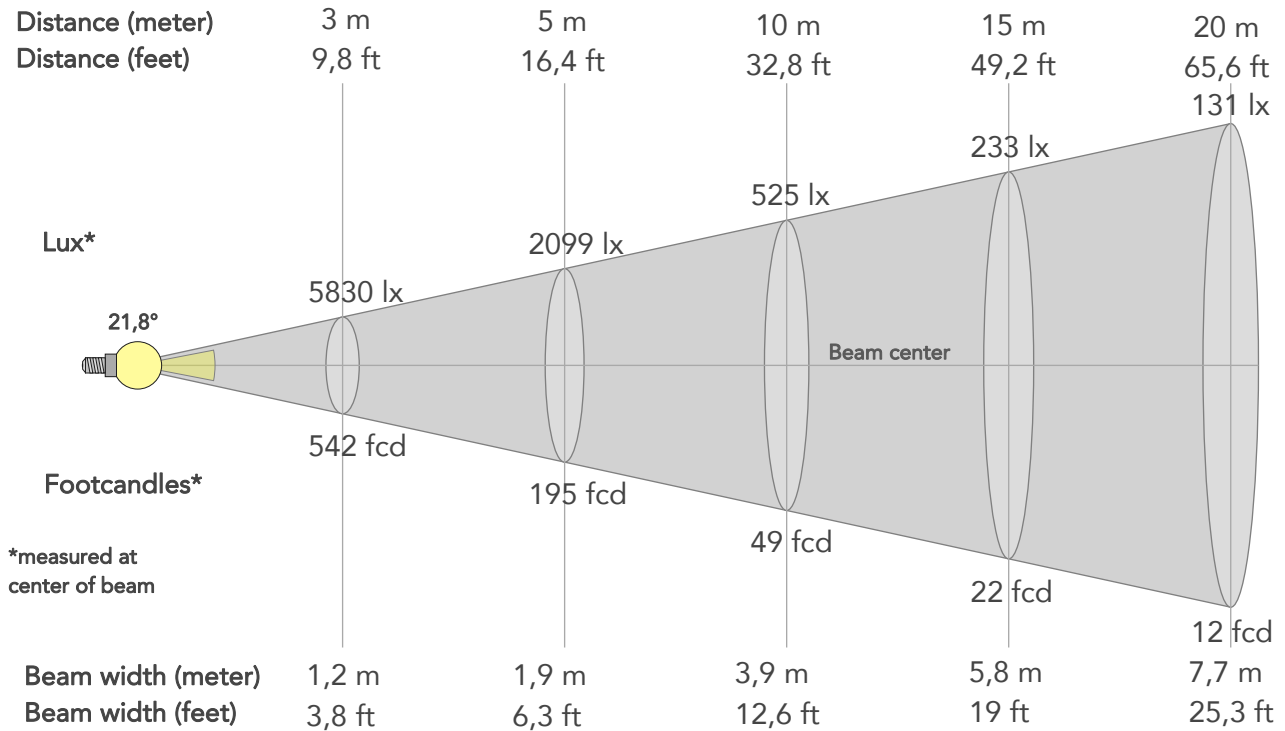

## BEAM INTENSITIES AND WIDTHS

Distance	1m	2m	3m	4m	5m	7,5m	10m	15m	20m	25m	30m	40m	50m
Distance	3,3ft	6,6ft	9,8ft	13,1ft	16,4ft	24,6ft	32,8ft	49,2ft	65,6ft	82ft	98,4ft	131,2ft	164ft
Lux	52474lx	13118lx	5830lx	3280lx	2099lx	933lx	525lx	233lx	131lx	84lx	58lx	33lx	21lx
Footcand.	4875fcd	1219fcd	542fcd	305fcd	195fcd	87fcd	49fcd	22fcd	12fcd	8fcd	5fcd	3fcd	2fcd
Beam wid.	0,4m	0,8m	1,2m	1,5m	1,9m	2,9m	3,9m	5,8m	7,7m	9,6m	11,6m	15,4m	19,3m
Beam wid.	1,3ft	2,5ft	3,8ft	5,1ft	6,3ft	9,5ft	12,6ft	19ft	25,3ft	31,6ft	37,9ft	50,6ft	63,2ft

## LINEAR DISTRIBUTION DIAGRAM

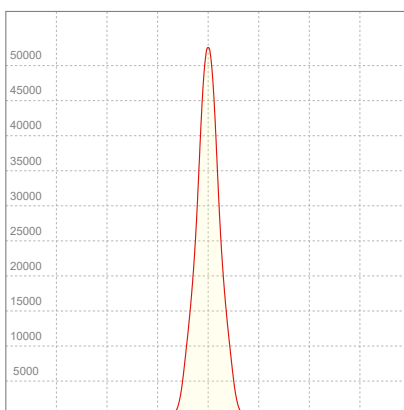

## ELECTRICAL SPECIFICATIONS

Input voltage	Input current	Input power	Effeciency
225V	2,12A	475,7W	21lm/W



## ISO CANDELA DIAGRAM

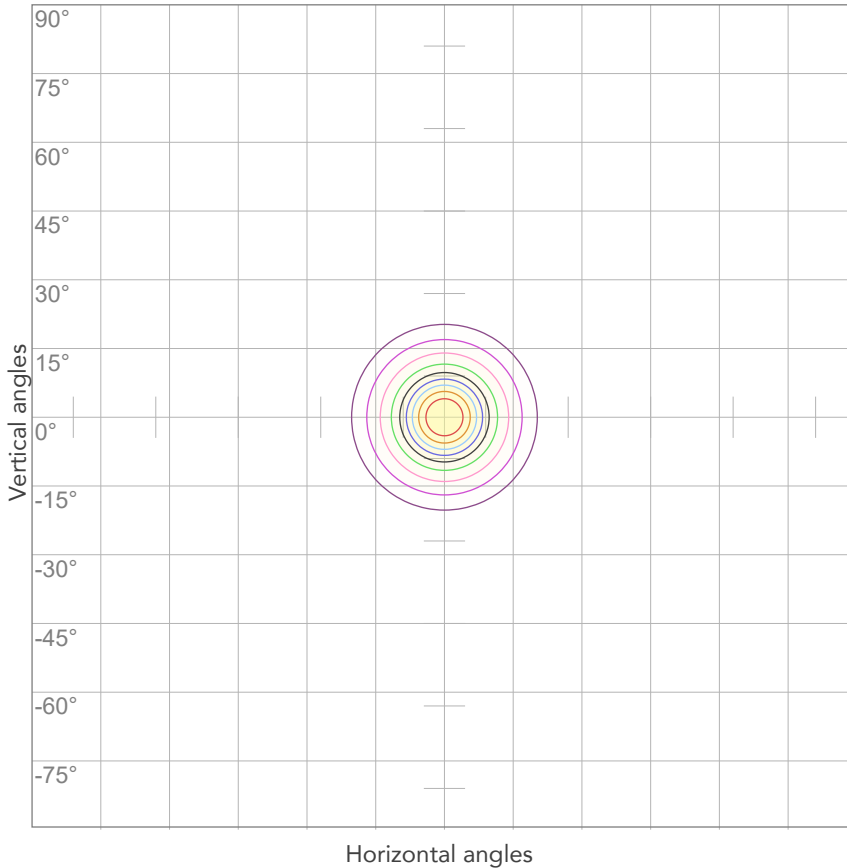

10%	5247 cd
20%	10495 cd
30%	15742 cd
40%	20989 cd
50%	26237 cd
60%	31484 cd
70%	36732 cd
80%	41979 cd

Conditions:

Number of c-planes: 2

Candela at center: 52474 cd

## ISO LUX DIAGRAM

MH: 10,0 m

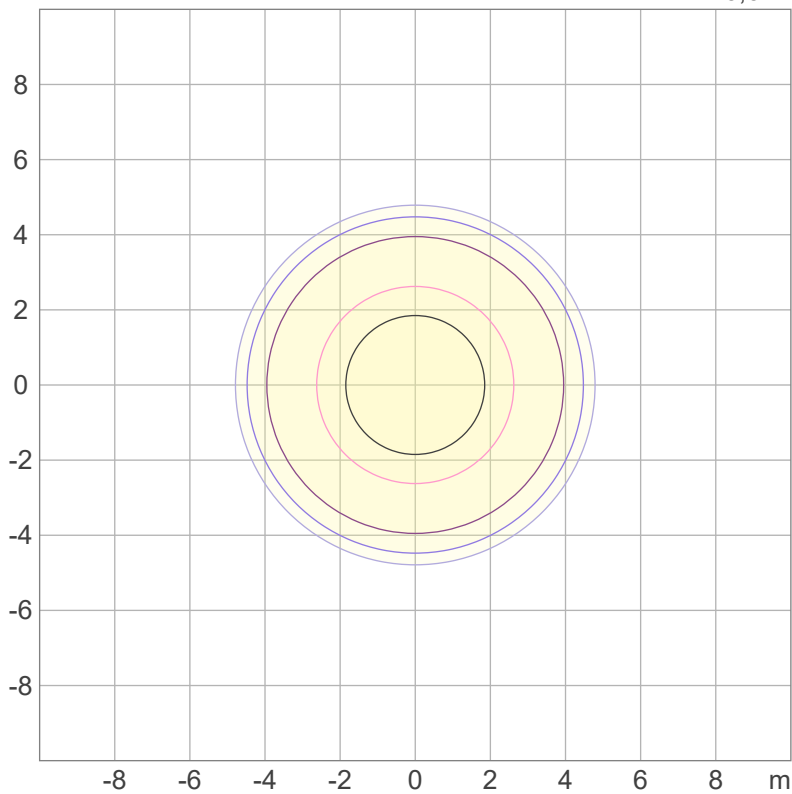

Mounting height: 10 meters (33 feet)

3%	15,7 lx
5%	26,2 lx
10%	52,5 lx
30%	157 lx
50%	262 lx

Conditions:

Number of c-planes: 2

Lux at center: 525 lx

*Lux distribution on a surface when lamp is mounted at 10 meters from the surface.*



Total lumen output:

5336 lm

Peak candela output:

140014 cd

Light quality:

CRI: 94,6

Color temperature:

6087 K

**PRODUCT NAME:**

**ECLFRCTPLIP**

**MEASURAMENT CONDITIONS:**

Beam angle:

Min Zoom

Target:

6000K - HB

Operator:

Salvatore Giglio

Date and time:

03/10/2023 14:06:16

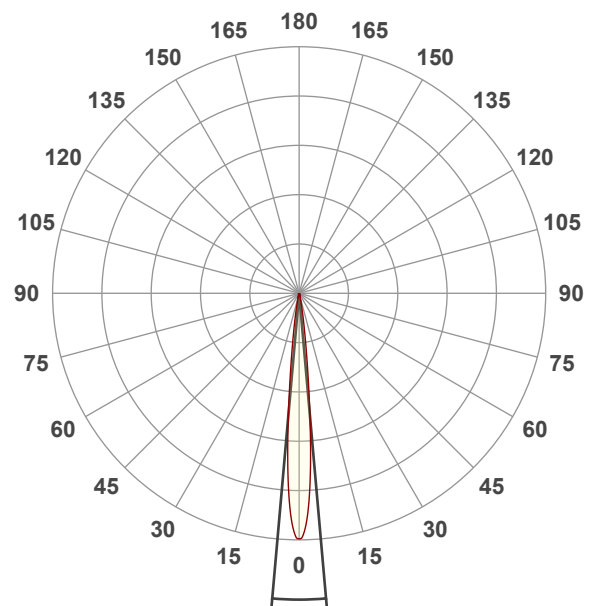

Spectra

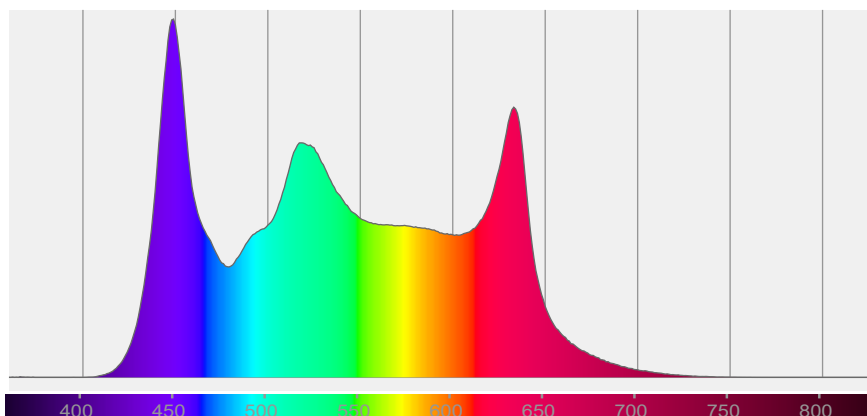

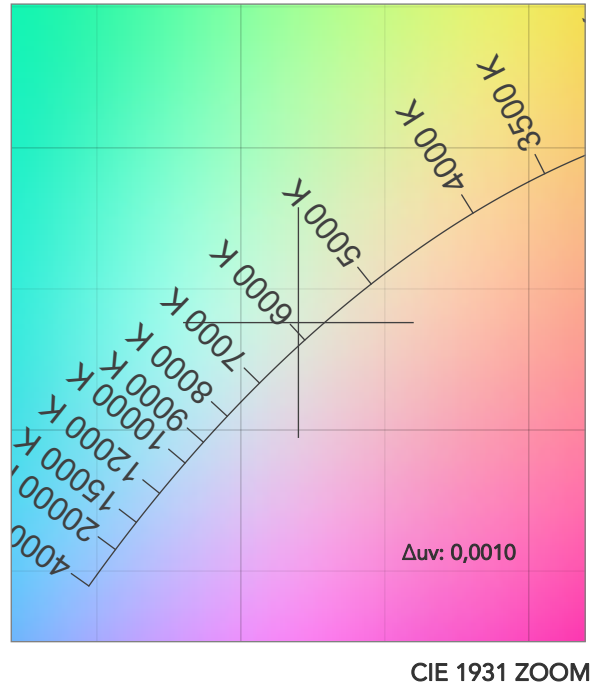
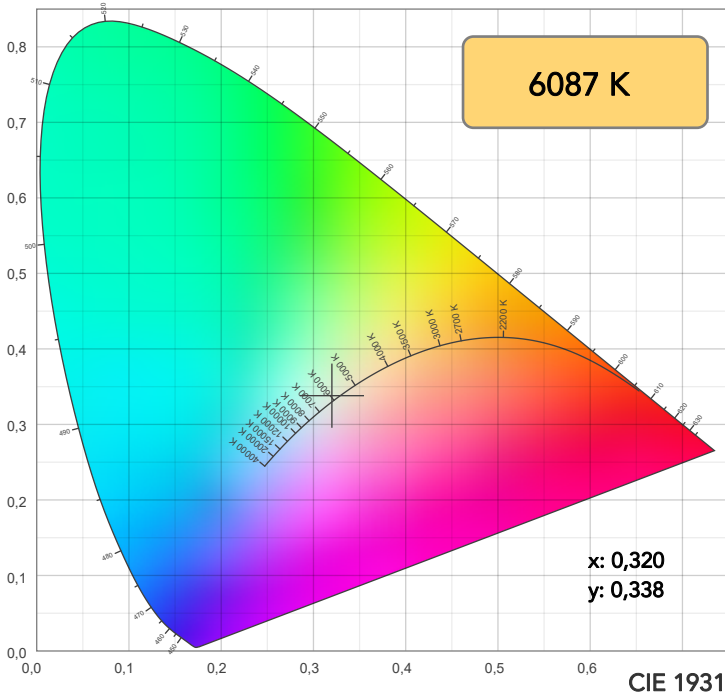

TM30: 93,7

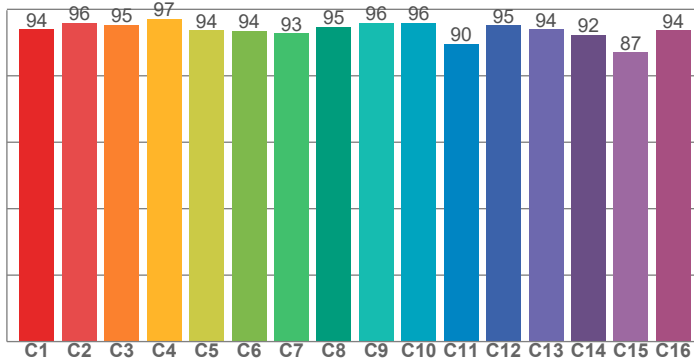

CRI: 94,6 (R1-R8)

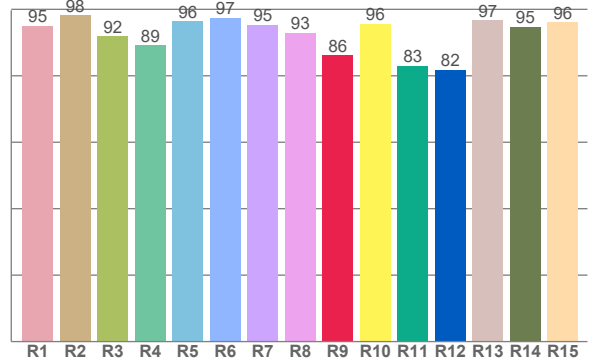

CRI R values, only R1-R8 are used to calculate final CRI value

R1	R2	R3	R4	R5	R6	R7	R8	R9	R10	R11	R12	R13	R14	R15
95,1	98,2	91,9	89,3	96,3	97,5	95,4	93,0	86,1	95,7	83,1	81,8	96,7	94,7	96,1

TM30 C values, 16 binned values out of total of 99 C values

C1	C2	C3	C4	C5	C6	C7	C8	C9	C10	C11	C12	C13	C14	C15	C16
94,0	95,9	95,3	97,1	93,7	93,6	92,7	94,7	95,9	95,9	89,6	95,1	93,9	92,4	87,0	93,6

CQS Q values

Q1	Q2	Q3	Q4	Q5	Q6	Q7	Q8	Q9	Q10	Q11	Q12	Q13	Q14	Q15
98,9	99,2	91,8	98,0	94,9	93,3	97,5	96,5	96,0	98,0	95,7	94,4	94,5	97,9	98,0

CQS: 95,8

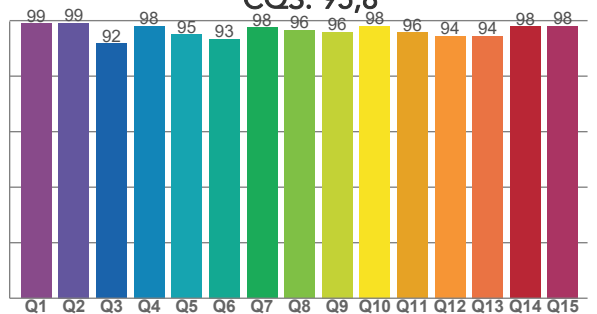

COLOR PARAMETERS

Color temperature	Color rendering index	Red component	Color fidelity	Color gamut	Color quality scale	Television lighting index	Color coordinate cie 1931	Color coordinate cie 1931	Color deviation from black body
CCT	CRI	CRI R9	TM30 Rf	TM30 Rg	CQS	TLCI	x	y	Δuv
6087 K	94,6	86,1	93,7	104,2	95,8	94	0,320	0,338	0,0010

# TM30 DETAILS

**Rf 93,7**  
Fidelity index Rf

**Rg 104,2**  
Gammut index

Hue Bin	R <sub>f</sub>	Graphic shifts (%)	
		Chroma	Hue
1	94	2%	-1%
2	96	2%	-2%
3	95	1%	-1%
4	97	-1%	0%
5	94	-2%	1%
6	94	3%	3%
7	93	5%	1%
8	95	2%	0%
9	96	1%	1%
10	96	0%	2%
11	90	2%	6%
12	95	2%	0%
13	94	4%	-2%
14	92	3%	1%
15	87	10%	-6%
16	94	3%	-1%

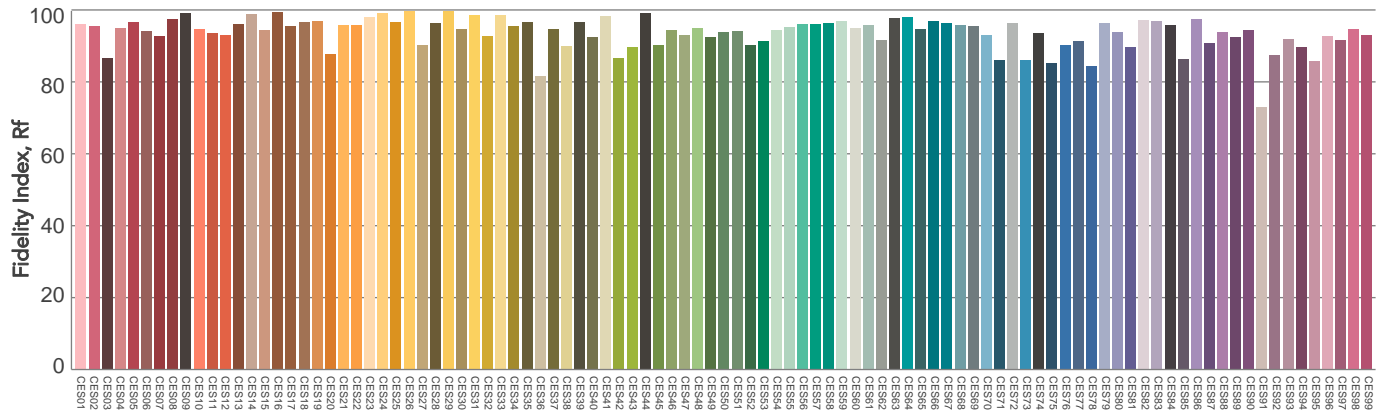
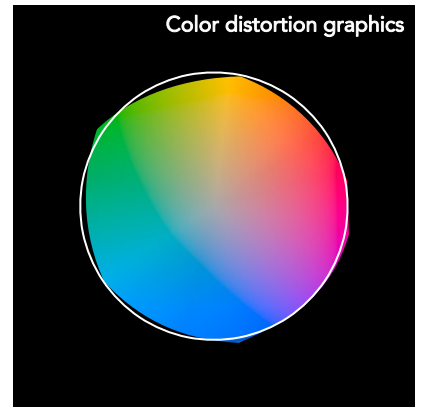
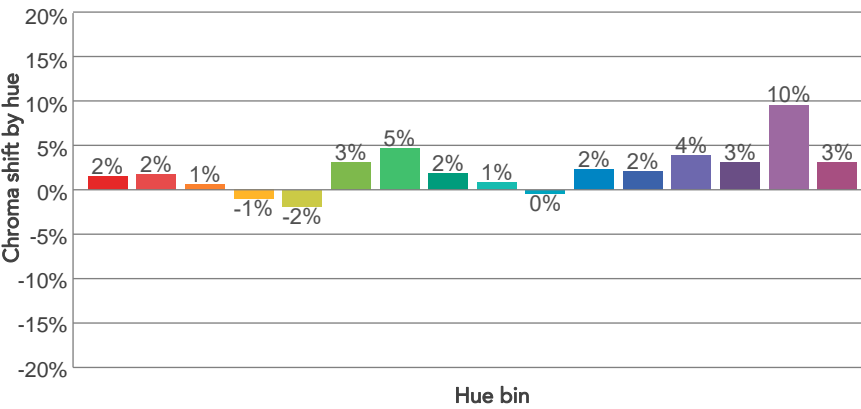
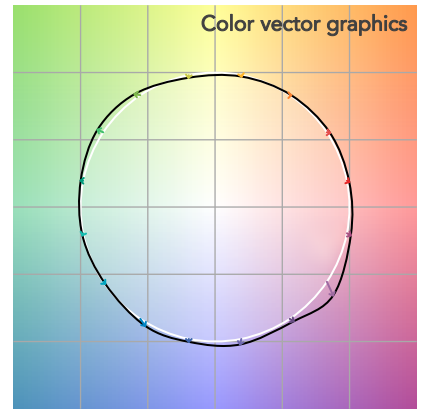
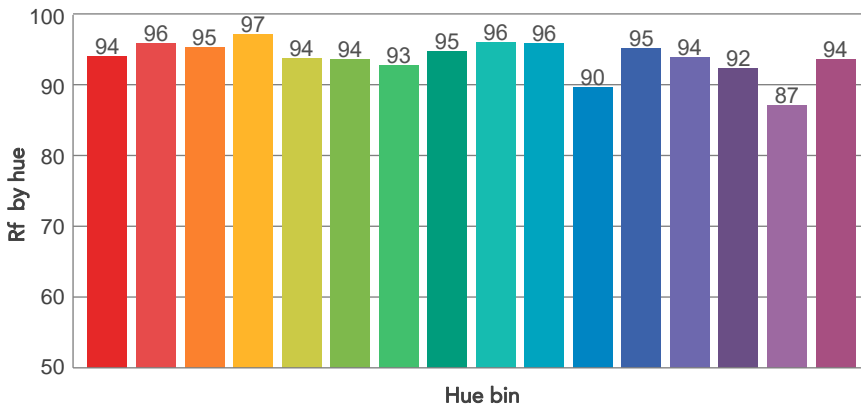
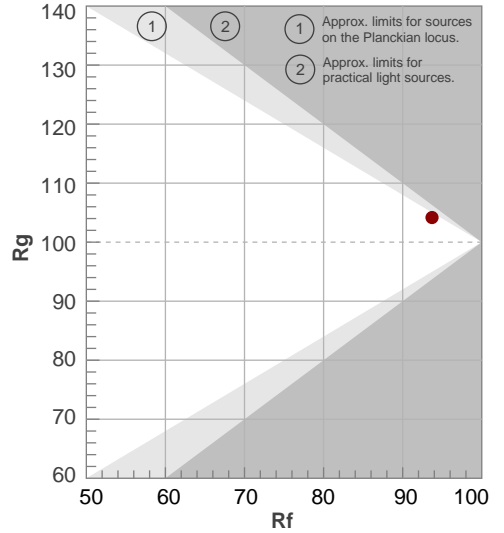

# BEAM DETAILS



Beam angle 50%	Field angle 10%	Cut off angle 2,5%	Intensity ratio in 120° cone	Intensity ratio in 90° cone
10,1°	18,6°	26°	100,0%	100,0%

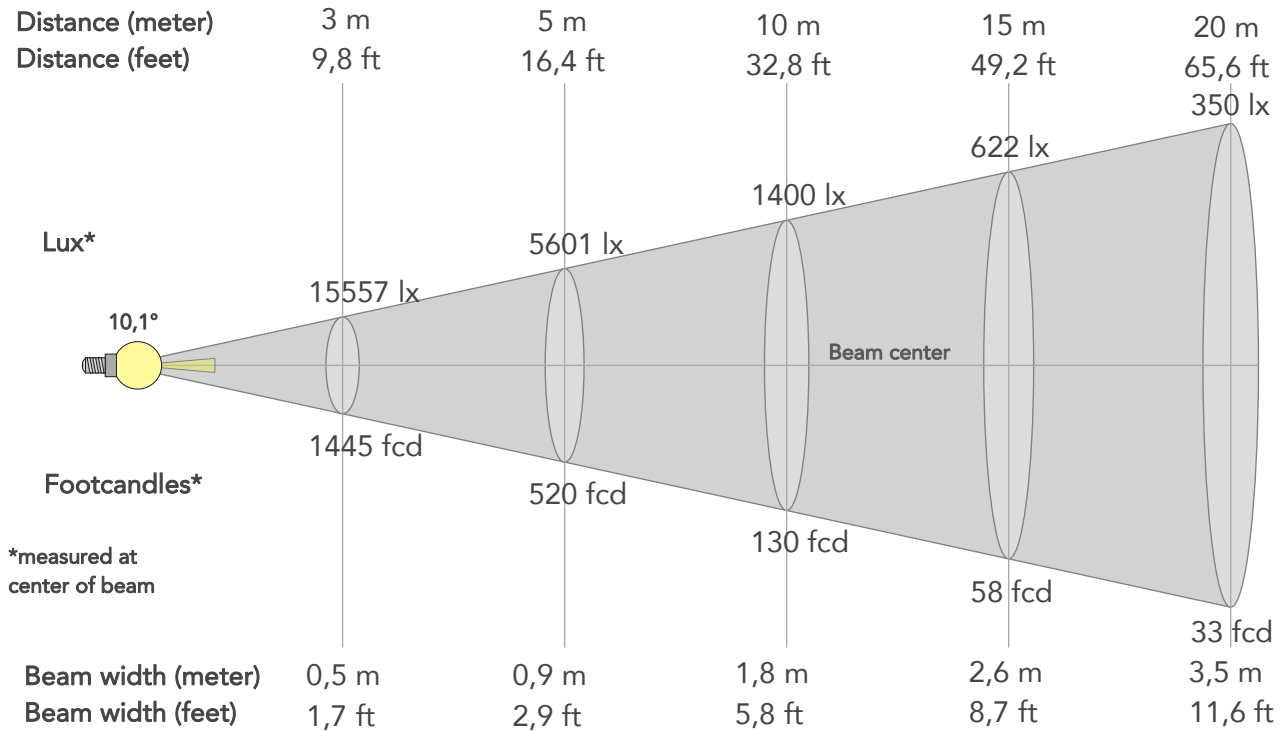

## BEAM INTENSITIES AND WIDTHS

Distance	1m	2m	3m	4m	5m	7,5m	10m	15m	20m	25m	30m	40m	50m
Distance	3,3ft	6,6ft	9,8ft	13,1ft	16,4ft	24,6ft	32,8ft	49,2ft	65,6ft	82ft	98,4ft	131,2ft	164ft
Lux	140014lx	35004lx	15557lx	8751lx	5601lx	2489lx	1400lx	622lx	350lx	224lx	156lx	88lx	56lx
Footcand.	13008fcd	3252fcd	1445fcd	813fcd	520fcd	231fcd	130fcd	58fcd	33fcd	21fcd	14fcd	8fcd	5fcd
Beam wid.	0,2m	0,4m	0,5m	0,7m	0,9m	1,3m	1,8m	2,6m	3,5m	4,4m	5,3m	7,1m	8,8m
Beam wid.	0,6ft	1,2ft	1,7ft	2,3ft	2,9ft	4,3ft	5,8ft	8,7ft	11,6ft	14,5ft	17,4ft	23,1ft	28,9ft

## LINEAR DISTRIBUTION DIAGRAM

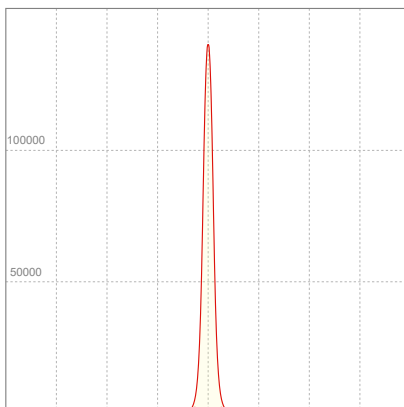

## ELECTRICAL SPECIFICATIONS

Input voltage	Input current	Input power	Effeciency
226V	2,11A	475,4W	11lm/W

## ISO CANDELA DIAGRAM

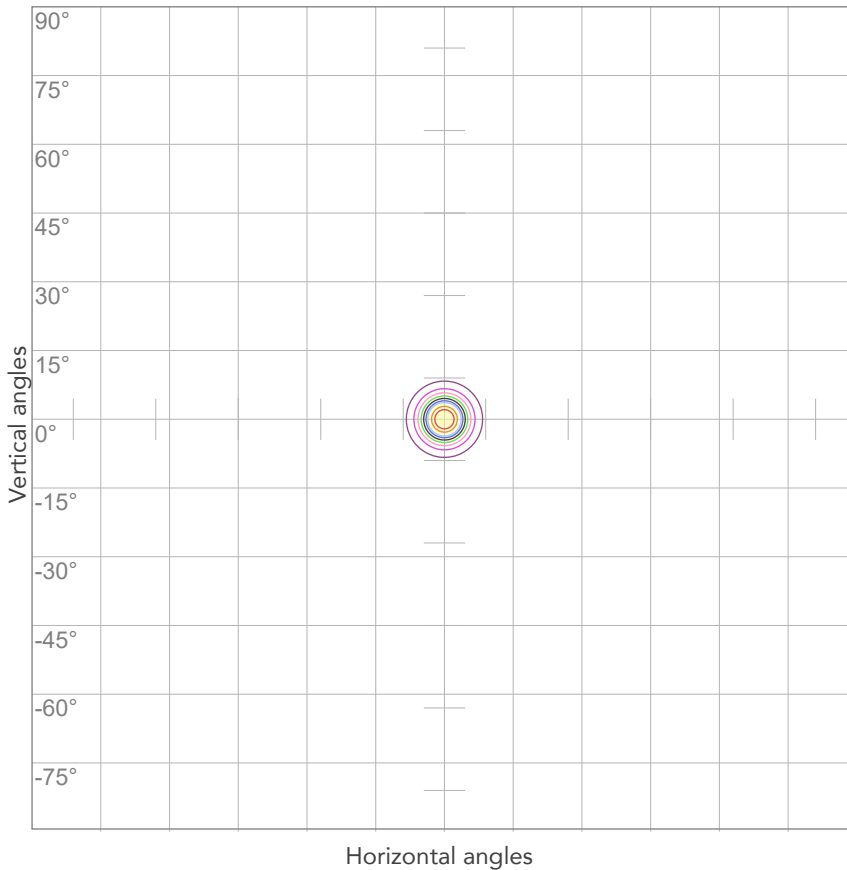

10%	14001 cd
20%	28003 cd
30%	42004 cd
40%	56006 cd
50%	70007 cd
60%	84009 cd
70%	98010 cd
80%	112011 cd

Conditions:

Number of c-planes: 2

Candela at center: 140014 cd

## ISO LUX DIAGRAM

MH: 10,0 m

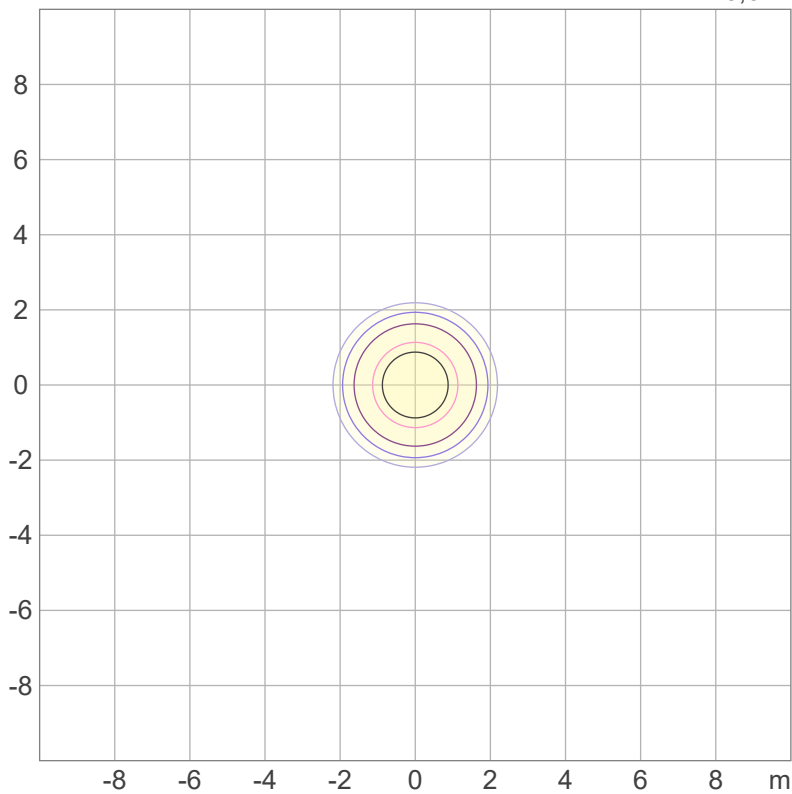

Mounting height: 10 meters (33 feet)

3%	42,0 lx
5%	70,0 lx
10%	140 lx
30%	420 lx
50%	700 lx

Conditions:

Number of c-planes: 2

Lux at center: 1400 lx

*Lux distribution on a surface when lamp is mounted at 10 meters from the surface.*