



EclFresnel CT+M

EclFresnel CT+MIP

350W 6 colours LED Fresnel with 9,4°-80,8° zoom



USER MANUAL

Thank you for choosing PROLIGHTS

Please note that every PROLIGHTS product has been designed in Italy to meet quality and performance requirements for professionals and designed and manufactured for the use and application as shown in this document.

Any other use, if not expressly indicated, could compromise the good condition/operation of the product and/or be a source of danger.

This product is meant for professional use. Therefore, commercial use of this equipment is subject to the respectively applicable national accident prevention rules and regulations.

Features, specifications and appearance are subject to change without notice. Music & Lights S.r.l. and all affiliated companies disclaim liability for any injury, damage, direct or indirect loss, consequential or economic loss or any other loss occasioned by the use of, inability to use or reliance on the information contained in this document.

Product user manual can be downloaded from the website www.prolights.it, or can be inquired to the official PROLIGHTS distributors of your territory (https://www.prolights.it/sales_network.html).

Scanning the below **QR Code**, you will access the download area of the product page, where you can find a broad set of always updated technical documentation: specifications, user manual, technical drawings, photometrics, personalities, fixture firmware updates.



EclFresnel CT+M

Visit the download area
of the product page



EclFresnel CT+MIP



The PROLIGHTS Logo, PROLIGHTS names and all other trademark in this document pertaining to PROLIGHTS services or PROLIGHTS product are trademarks OWNED or licensed by Music & Lights S.r.l., its affiliates, and subsidiaries. PROLIGHTS is a registered trademark by Music & Lights S.r.l. All right reserved. Music & Lights – Via A. Olivetti, snc - 04026 - Minturno (LT) ITALY.

INDEX

SAFETY INFORMATION	02
1 - PACKAGING	05
PACKAGE CONTENT	05
OPTIONAL ACCESSORIES	05
2 - TECHNICAL DRAWING	06
3 - INSTALLATION	10
MOUNTING	10
4 - CONNECTION TO THE MAINS SUPPLY	11
5 - START UP	11
CONNECT AND DISCONNECT POWER FROM THE PRODUCT	11
6 - PRODUCT OVERVIEW	12
7 - DMX CONNECTION	13
CONNECTION OF THE CONTROL SIGNAL: DMX LINE	13
INSTRUCTIONS FOR A RELIABLE DMX CONNECTION	13
CONNECTION DAISY CHAIN	13
CONNECTION OF THE DMX LINE	13
CONSTRUCTION OF THE DMX TERMINATION	14
DMX ADDRESSING	14
8 - CONTROL PANEL	15
DISPLAY AND BUTTONS LAYOUT	15
9 - MENU STRUCTURE	16
10 - RDM FUNCTIONS	20
11 - DMX CHARTS	21
12 - ACCESSORIES INSTALLATION	58
FILTER FRAME (CODE ECLFRCTPMFF)	58
BARN DOOR (CODE ECLFRCTPMBD)	59
SLIDING BRACKET MOVEMENT	60
13 - MAINTENANCE	61
MAINTENANCE AND CLEANING THE PRODUCT	61
REPLACING THE FUSE	61
VISUAL CHECK OF PRODUCT HOUSING	61
TROUBLESHOOTING	62

SAFETY INFORMATION



WARNING!

- See <https://www.prolights.it/product/ECLFRCTPM#download> for installation instructions.
- Please read carefully the instruction reported in this section before installing, powering, operating or servicing the product and observe the indications also for its future handling.



This unit is not for household use, only professional applications.



Connection to mains supply

- The Connection to the mains supply must be carried out by a qualified electrical installer.
- Use only AC supplies 100-240V 50-60 Hz, the fixture must be electrically connected to ground (earth).
- Select the cable cross section in according with the maximum current draw of the product and the possible number of products connected at the same power line.
- The AC mains power distribution circuit must be equipped with magnetic+residual current circuit breaker protection.
- Do not connect it to a dimmer system; doing so may damage the product.



Protection and Warning against electrical shock

- Do not remove any cover from the product, always disconnect the product from AC power before servicing.
- Ensure that the fixture is electrically connected to ground (earth). And use only a source of AC power that complies with local building and electrical codes and has both overload and ground-fault (earth-fault) protection.
- Before using the fixture, check that all power distribution equipment and cables are in perfect condition and rated for the current requirements of all connected devices.
- Isolate the fixture from power immediately if the power plug or any seal, cover, cable, or other components are damaged, defective, deformed or showing signs of overheating.
- Do not reapply power until repairs have been completed.
- Refer any service operation not described in this manual to PROLIGHTS Service team or an authorized PROLIGHTS service center.



Installation

- Make sure that all visible parts of the product are in good visible condition before its use or installation.
- Make sure the point of anchorage is stable before positioning the projector.
- When suspending the fixture above ground level, secure it against failure of primary attachments by attaching a safety cable that is approved as a safety attachment for the weight of the fixture to the attachment point on the main frame of the product. In case the safety cable, enter in action, it needs to be replaced with a new one.
- Install the product only in well ventilated places.
- For non temporary installations, ensure that the fixture is securely fastened to a load-bearing surface with suitable corrosion-resistant hardware.
- For a temporary installation with clamps, ensure that the quarter-turn fastener and/or screws are turned fully, and secured with a suitable safety cable.



Minimum distance of illuminated objects

- The projector needs to be positioned so that the objects hit by the beam of light are at least 0.5 meters (1.64 ft) from the lens of the projector.



Protection from burns and fire

- The exterior of the fixture becomes hot during use. Avoid contact by persons and materials.
- Ensure that there is free and unobstructed airflow around the fixture.
- Keep flammable materials well away from the fixture
- Do not expose the front glass to sunlight or any other strong light source from any angle. Lenses can focus the sun's rays inside the fixture, creating a potential fire hazard.
- Do not attempt to bypass thermostatic switches or fuses.



Maintenance

- Warning! Disconnect the fixture from AC mains power and allow to cool for at least 10 minutes before handling.
- Only technicians who are authorized by PROLIGHTS or Authorised service partners are permitted to open the fixture.
- Users may carry out external cleaning, following the warnings and instructions provided, but any service operation not described in this manual must be referred to a qualified service technician.
- Important! Excessive dust, smoke fluid, and particle build up degrades performance, causes overheating and will damage the fixture. Damages caused by inadequate cleaning or maintenance is not covered by the product warranty.



Photobiological safety

- This device emits potentially dangerous optical radiation and is identified in the category of Risk Group 2 according to EN 62471.



Disposal

- This product is supplied in compliance with European Directive 2012/19/EU – Waste Electrical and Electronic Equipment (WEEE). To preserve the environment please dispose/ recycle this product at the end of its life according to the local regulation.



The products to which this manual refers comply with:

- 2014/35/EU - Safety of electrical equipment supplied at low voltage (LVD).
- 2014/30/EU - Electromagnetic Compatibility (EMC).
- 2011/65/EU - Restriction of the use of certain hazardous substances (RoHS).



Les produits auxquels ce manuel fait référence sont conformes:

- UL 1573 + CSA C22.2 n° 166 - Luminaires de scène et de studio et barrettes de connexion.
- UL 1012 + CSA C22.2 N° 107.1 - Norme pour les unités de puissance autres que la classe 2.



Conformité FCC:

- Cet appareil est conforme à la partie 15 des règles de la FCC. L'exploitation est soumise aux deux conditions suivantes:
 1. Cet appareil ne doit pas causer d'interférences nuisibles et
 2. Cet appareil doit accepter toute interférence reçue, y compris les interférences pouvant provoquer un fonctionnement indésirable.



Other approvals





Do not stare at the operating light source

- Do not look directly at the LED source during operation. It can be harmful to the eyes and skin.
- During Installation, operation and maintenance, be prepared for the fixture to light and move suddenly when connected to power.
- The device should be positioned so that prolonged staring into the luminaire at a distance closer than 14,54 m (47,70 ft) is not expected.

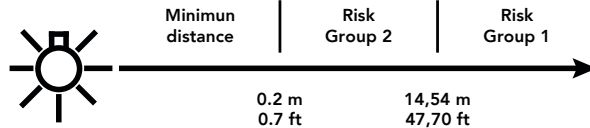

ECLFRCTPM - IP20 Version



Indoor use

- This product is designed for indoor and dry environments.
- Do not use in wet location and do not expose the fixture to rain or moisture.
- Never use the fixture in places subject to vibrations or bumps.
- Make certain that no inflammable liquids, water or metal objects enter the fixture.
- Excessive dust, smoke fluid, and particle build up degrades performance, causes overheating and will damage the fixture.
- Damages caused by inadequate cleaning or maintenance are not covered by the product warranty.

T_a45°C

Max operating ambient temperature (T_a)

- Do not operate the fixture if the ambient temperature (T_a) exceeds 45 °C (113 °F).

T_a-10°C

Minimum operating ambient temperature (T_a)

- Do not operate the fixture if the ambient temperature (T_a) is below -10 °C (14 °F).

T_c70°C

Temperature of the external surface

- The surface of the fixture can reach up to 70 °C (158 °F) during operation. Avoid contact with people and materials.

ECLFRCTPMIP - IP65 Version

IP65

Permanent Outdoor use

- This product is rated with an IP (Ingress protection) for permanent outdoor use when used and serviced according to the instruction contained in this document.
- Never use the fixture in places subject to vibrations or bumps.
- Make certain that no inflammable liquids, water or metal objects enter the fixture.
- Excessive dust, smoke fluid, and particle build up degrades performance, causes overheating and will damage the fixture.
- Damages caused by inadequate cleaning or maintenance are not covered by the product warranty.

T_a45°C

Max operating ambient temperature (T_a)

- Do not operate the fixture if the ambient temperature (T_a) exceeds 45 °C (113 °F).

T_a-20°C

Minimum operating ambient temperature (T_a)

- Do not operate the fixture if the ambient temperature (T_a) is below -20 °C (-4 °F).

T_c80°C

Temperature of the external surface

- The surface of the fixture can reach up to 80 °C (176 °F) during operation. Avoid contact with people and materials.

1 - PACKAGING

PACKAGE CONTENT

- 1x ECLFRESNEL CT+M / CT+MIP;
- 1x ECLFRSPG: spigot for PROLIGHTS Fresnel series;
- 1x ECLFRCTPMBD: barn door with 8 directional flaps to adjust the light beam;
- 1x ECLFRCTPMFF: filter frame for ECLFRESNEL series;
- 1x 1,5 meters power cable (BARE END - NEUTRIK POWERCON TRUE1 IP65);
- 1x User manual

OPTIONAL ACCESSORIES

- FCLECLFRCTPM: Flight case for 4 pcs of ECLFRCTPM series
- ECLFRCTPMBAG1U: Empty ABS case for 1 pc of ECLFRCTPM series
- ECLFRCTPMKPOYO: Pole operated aluminium yoke bracket and zoom kit for ECLFRCTPM series
- SPGM10: 28mm spigot for fixtures, M10 bolt
- SPGM12: 28mm spigot for fixtures, M12 bolt
- LRMT2SPIBK: CRMX Timo Two SPI kit, black
- EFSBUFDS: SNAPBAG - Universal Small Deeper for barndoors
- SPGM10: 28mm spigot for fixtures, M10 bolt
- SPGM12: 28mm spigot for fixtures, M12 bolt
- UPBOXPRO: Firmware uploader kit, USB IN, 5pin XLR DMX OUT
- UPBOX1UP5: Firmware uploader kit, USB IN, 5pin XLR DMX OUT
- C6040B: Aluminum clamp for 28mm spigot, 200kg load, 48-51mm tubes, black inc
- TOUR53415L03: Dmx cable HC5340. CANC5MXX XLR 5p->CANC5FXX XLR (f) 5p, L.3m
- 958225L03: 3x2.5mm TH07 Cable, 16A 3p PwCon MXW, 16A 3p PwCon FXW, L. 3m
- 9513FXWL03: Ass. 3x2.5mm TH07 cable, 16A 3p 230V CEE plug, MENAC3FXW socket, L.3 m
- RSR0630B: Steel security cable for hanging bodies, inox steel shackle, L=60 cm, black
- C6002B: Slim aluminum clamp, 200kg loading, 48-51mm tubes, M10 bolt, Black
- 9533FXWL03: Ass. 3x2.5mm TH07 cable, SHUKO plug, MENAC3FXW socket, L.3m

2 - TECHNICAL DRAWING

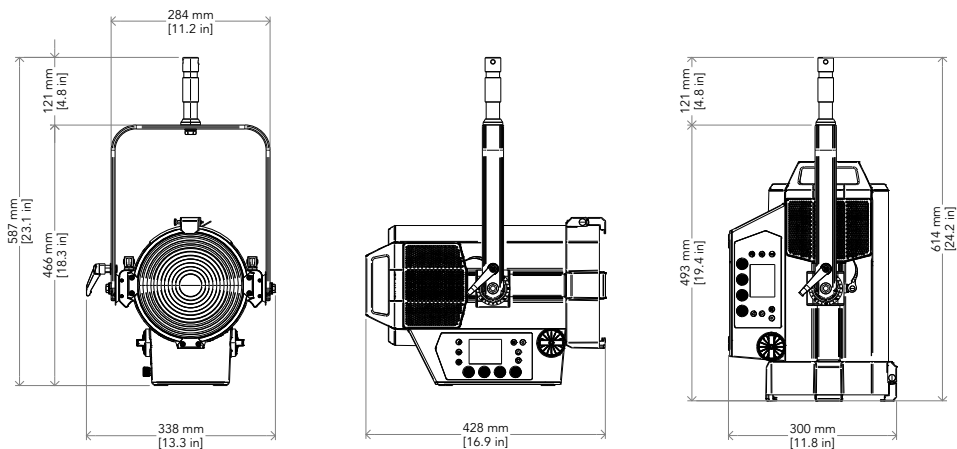

ECLFRCTPM - Weight: 9,9 kg / 21,82lbs

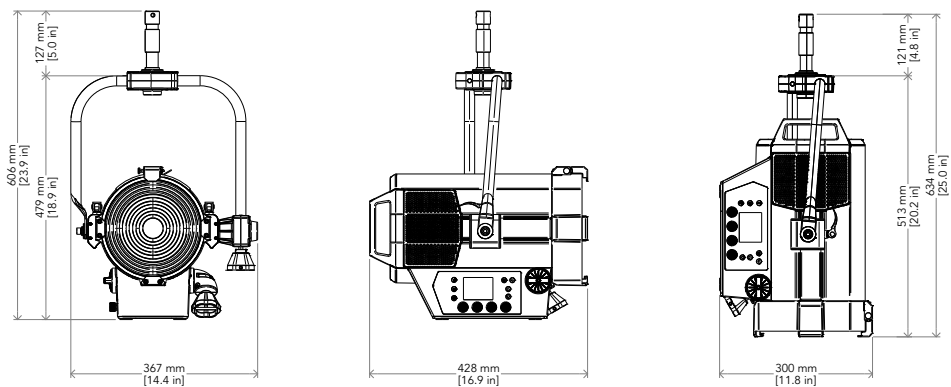

ECLFRCTPM+ECLFRCTPMKPOYO - Weight: 11,9 kg - 26,23 lbs

Fig. 01

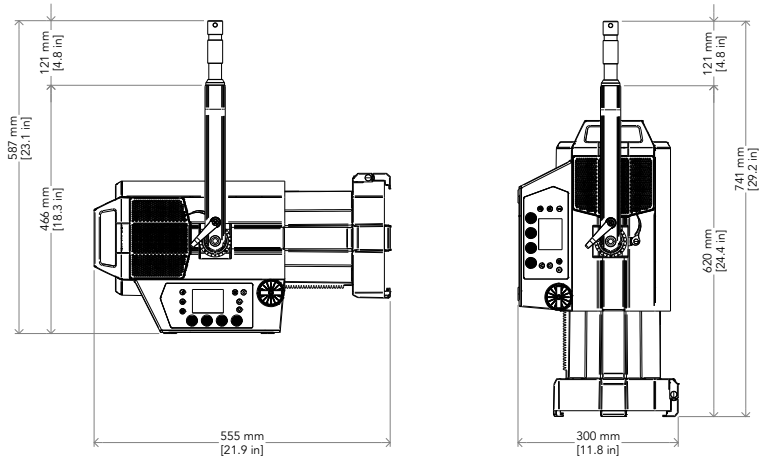

ECLFRCTPM - Weight: 9,9 kg / 21,82lbs

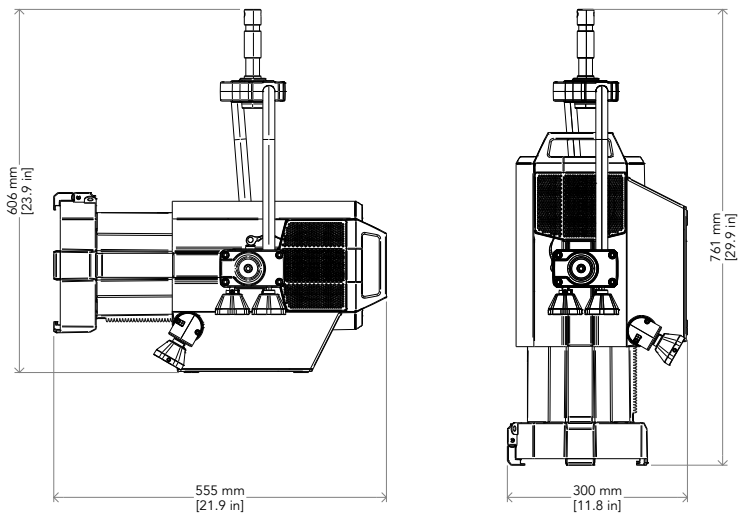

ECLFRCTPM+ECLFRCTPMKPOYO - Weight: 11,9 kg - 26,23 lbs

Fig. 02

2 - TECHNICAL DRAWING

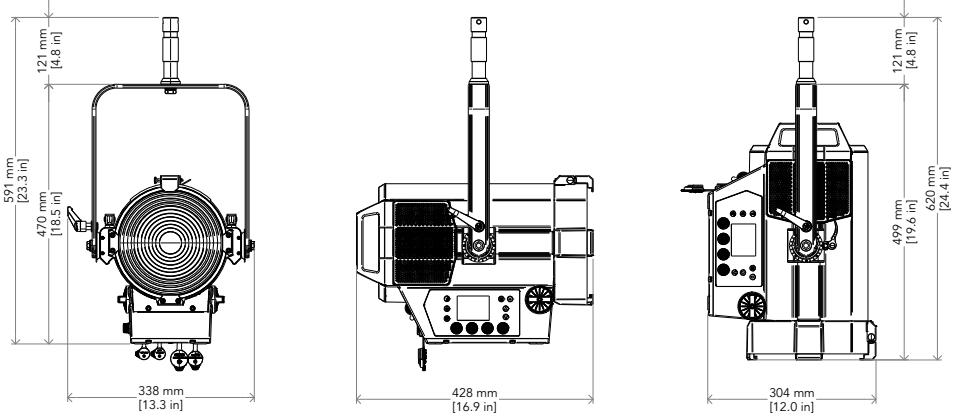

ECLFRCTPMIP - Weight: 10,9 kg / 24,03 lbs

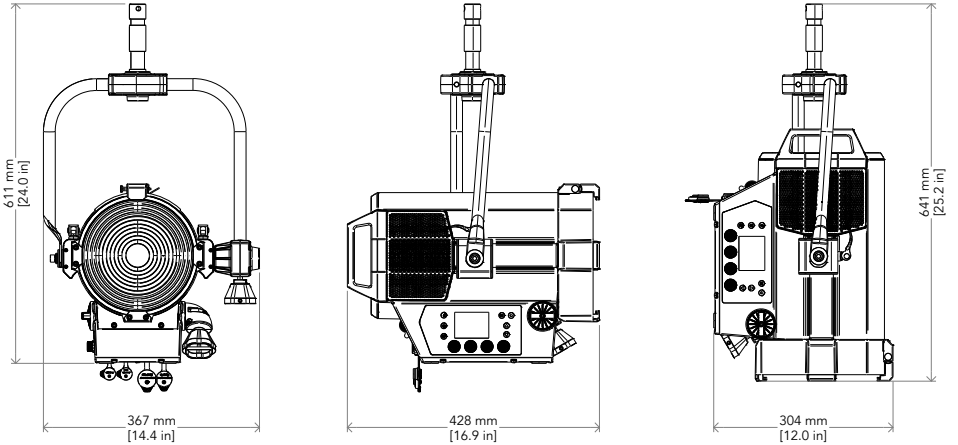

ECLFRCTPMIP+ECLFRCTPMKPOYO - Weight: 12,9 kg - 28,44 lbs

Fig. 01

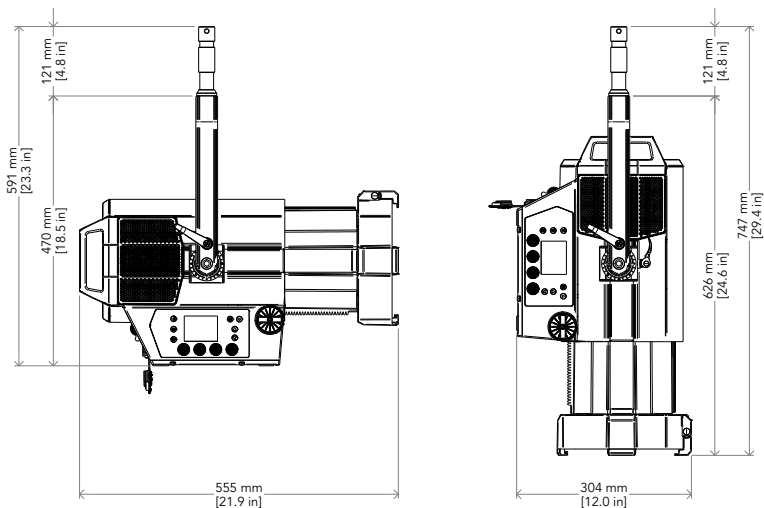

ECLFRCTPMIP - Weight: 10,9 kg / 24,03 lbs

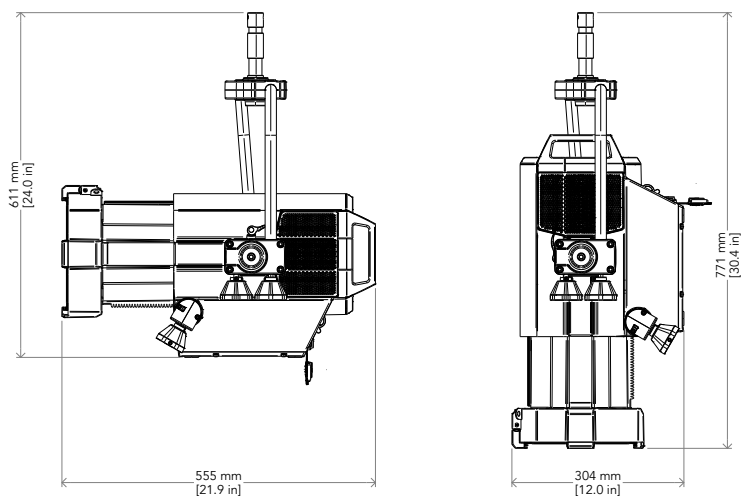

ECLFRCTPMIP+ECLFRCTPMKPOYO - Weight: 12,9 kg - 28,44 lbs

Fig. 02

3 - INSTALLATION

MOUNTING

Check that the supporting structure can safely bear the weight of all installed fixtures, clamps, cables, auxiliary equipment, etc. and complies with locally applicable regulations.

When suspending the fixture above ground level, secure it against failure of primary attachments by attaching a safety wire that is approved as a safety attachment for the weight of the fixture to an anchor point on the product main frame.

Do not use removable parts or weak anchors for secondary attachment.

Warning! When clamping the fixture to a truss or other structure at any angle, use clamps of half-coupler type. Do not use any type of clamp that does not completely encircle the structure when fastened.

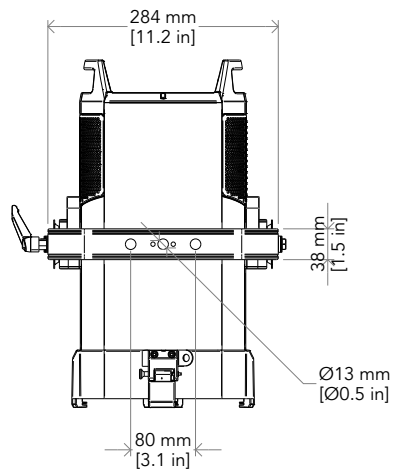
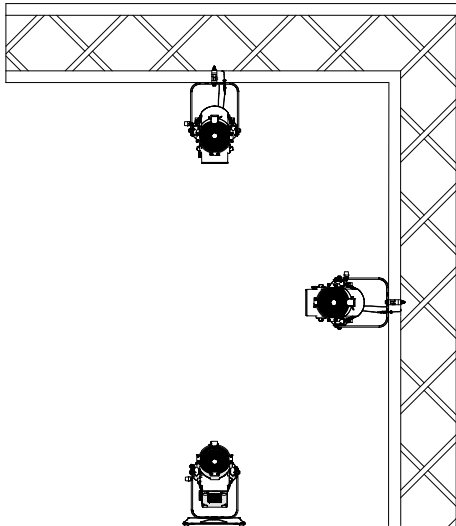
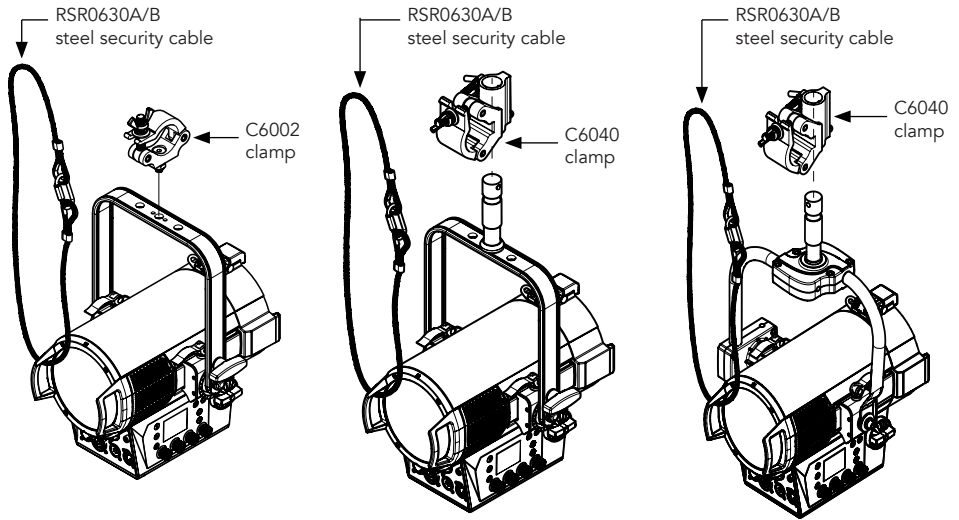

Fig. 03

4 - CONNECTION TO THE MAINS SUPPLY

WARNING: For protection from electric shock, the fixture must be earthed!

The product is equipped with auto-switching power supply that automatically adjusts to any 50-60Hz AC power source from 100-240 Volts.

If you need to install a power plug on the power cable to allow connection to power outlets, install a grounding-type (earthed) plug, following the plug manufacturer's instructions. If you have any doubts about proper installation, consult a qualified electrician.

The max power consumption is 350W.

Core (EU)	Core (US)	Connection	Plug terminal marking
Brown	Black	Live	L
Blue	White	Neutral	N
Yellow+green	Green	Earth	

5 - START UP

CONNECT AND DISCONNECT POWER FROM THE PRODUCT

To apply and disconnect power to the product:

- Check that the product is installed and secured as indicated in the Safety Informations, and that personal safety will not be put at risk when the fixture lights up.
- Connect the power connector into the Mains input socket (100-240 VAC-50/60 Hz).
- The product is then ready for its operations and can be controlled through the available input signals on board.
- To disconnect power from the product, disconnect the Mains from the socket.

6 - PRODUCT OVERVIEW

1. SLIDING BRACKET;
2. KNOB for bracket;
3. USER INTERFACE with display and ROTATORY KNOBS for access to the control panel functions;
4. ZOOM KNOB;
5. Sliding bracket lock and release mechanism;
6. POLE OPERATED BRACKET;
7. YELLOW KNOB: zoom function;
8. WHITE KNOB: tilt function;
9. BLUE KNOB: pan function;
- 10.DC POWER IN (3-pole XLR): for battery within 48 V range, 1 = V -, 2 = V+, 3 = N/C
- 11.MAIN FUSE HOLDER: (ONLY IP20) replace a burnt-out fuse by one of the same type only (T6.3A 250V);
- 12.WEIPU SA12 series 4P-F connector for remote control;
- 13.ANTENNA (Included in IP65, Optional kit LRTM2SPIBK for IP20);
- 14.POWER IN: for connection to the Mains 100-240V~/50-60Hz;
- 15.POWER OUT: power output for connection of multiple units in series.
- 16.DMX IN (5-p XLR): 1 = GND, 2 = sign-, 3 = sign+, 4 N/C, 5 N/C;
- 17.DMX OUT (5-p XLR): 1 = GND, 2 = sign-, 3 = sign+, 4 N/C, 5 N/C;

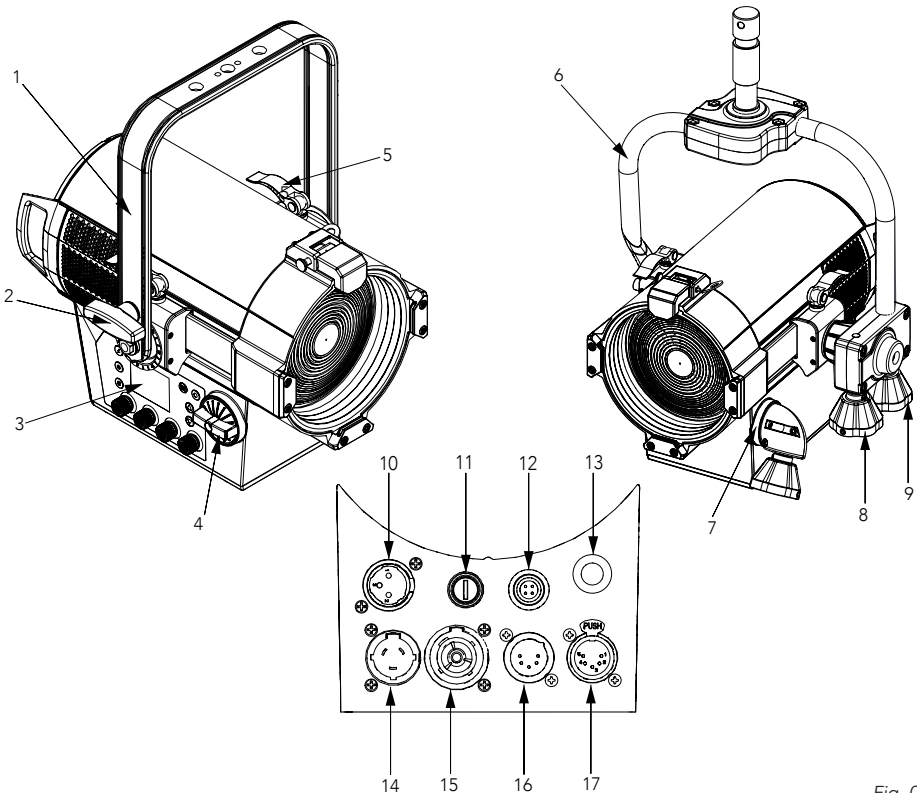

Fig. 04

7 - DMX CONNECTION

CONNECTION OF THE CONTROL SIGNAL: DMX LINE

The product has XLR sockets for DMX input and output.
The default pin-out on both socket is as the following diagram:

DMX - INPUT XLR plug



- Pin1 : GND - Shield
- Pin2 : - Signal
- Pin3 : + Signal
- Pin4 : N/C
- Pin5 : N/C

DMX - OUTPUT XLR socket



Fig. 05

INSTRUCTIONS FOR A RELIABLE DMX CONNECTION

Use shielded twisted-pair cable designed for RS-485 devices: standard microphone cable cannot transmit control data reliably over long runs. 24 AWG cable is suitable for runs up to 300 meters (1000 ft). Heavier gauge cable and/or an amplifier is recommended for longer runs.
To split the data link into branches, use splitter-amplifiers in the connection line.
Do not overload the link. Up to 32 devices may be connected on a serial link.

CONNECTION DAISY CHAIN

Connect the DMX data output from the DMX source to the product DMX input (male connector XLR) socket.
Run the data link from the product XLR output (female connector XLR) socket to the DMX input of the next fixture.
Terminate the data link by connecting a 120 Ohm signal termination. If a splitter is used, terminate each branch of the link.
Install a DMX termination plug on the last fixture on the link.

CONNECTION OF THE DMX LINE

DMX connection employs standard XLR connectors. Use shielded pair-twisted cables with 120Ω impedance and low capacity.
The following diagram shows the connection mode:

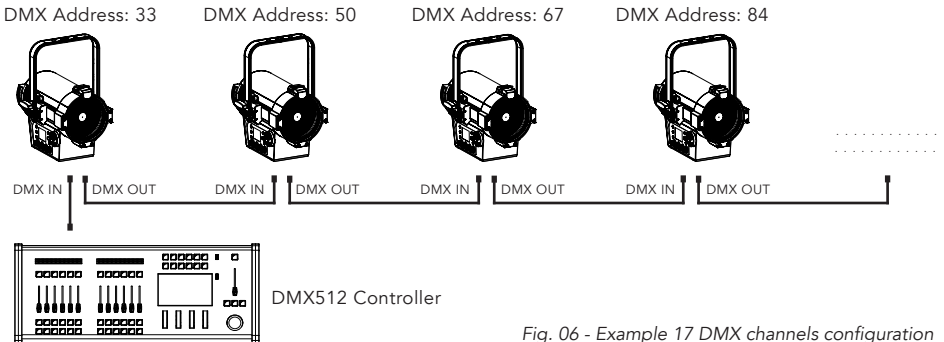

Fig. 06 - Example 17 DMX channels configuration

CONSTRUCTION OF THE DMX TERMINATION

The termination is prepared by soldering a 120Ω 1/4 W resistor between pins 2 and 3 of the male XLR connector, as shown in figure.

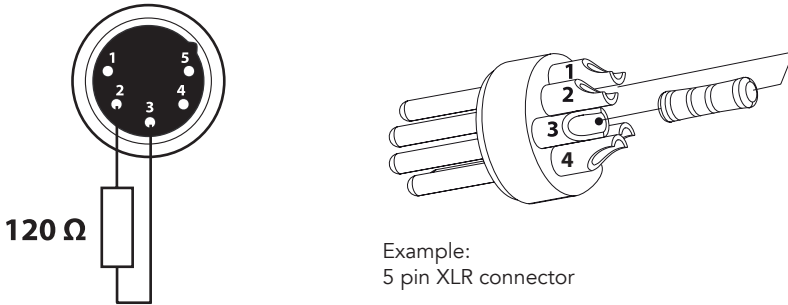

Fig. 07

DMX ADDRESSING

In order to start controlling the product via DMX, the first step is to select a DMX address, also known as the start channel, this is the first channel used to receive instructions from a DMX controller. If you wish to control the product individually, it is necessary to assign a different starting address channel to each fixture.

The number of channels occupied from the product depends on the DMX mode selected, so always verify the DMX Mode in the MENU before start addressing.

If you assign two fixtures the same address, they will be executing the same behaviour. Selecting the same address to multiple fixtures can be useful for diagnostic purposes and symmetrical control.

DMX addressing is limited to make it impossible to set the DMX address so high that you are left without enough control channels for the product.

To set the fixture's DMX address:

1. Press MENU to open the main menu.
2. Reach the addressing menu, then select the DMX ADDRESS settings.
3. Select the address from 1 to 512 using the navigation arrows/buttons and confirm by pressing ENTER.
4. Press Menu to exit and return to the Home screen.

8 - CONTROL PANEL

The product has a display and buttons for access to the control panel functions.

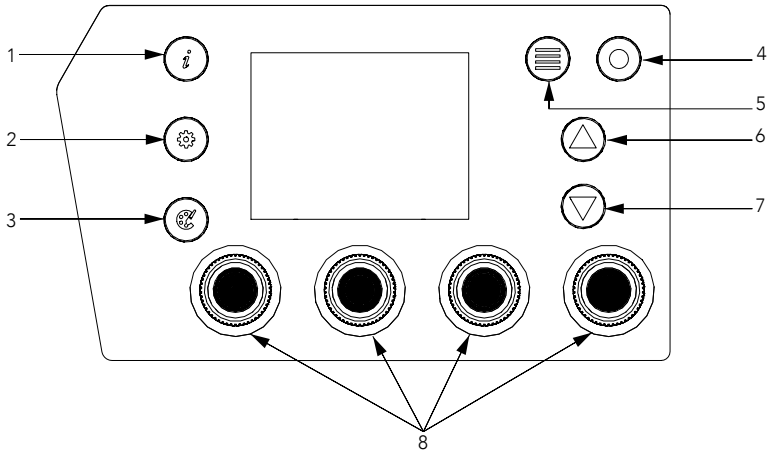

Fig. 08

DISPLAY AND BUTTONS LAYOUT

The product has a display and buttons for access to the control panel functions:

1. INFO: used to access in "Information", "current output", "documentation" windows.
2. SETTINGS: used to access in "quick settings" window.
3. PRESETS: CCT RGB HSI CIExy GEL, PRESET, Color Correction
4. ENTER: used to confirm the current menu or confirm the current value or option within a menu.
5. MENU: used to access the menu tree or to return a previous menu window;
6. UP: browse upwards through the menu list and increases the numeric value displayed;
7. DOWN: browse downwards through the menu list and decreases the numeric value displayed;
8. PUSHABLE ENCODERS: used to control stand alone modes.

9 - MENU STRUCTURE

The following chart describes the MENU tree of the product, the terms shown in **BOLD** indicates the default settings.

MENU					
1	DMX ADDRESS	001-512			
	DMX MODE	Mode			List of Modes without Color Correction. Example of mode. "M18 - CCT + RGB 16 Bit (20)"
		Mode + Color Correction			"Modes with Color Correction" should appear on the display only if Color Correction is set to ON
	Wireless	CRMX ON/OFF	On-Off		Hides all other CRMX settings, if off. Menu is hidden, if no W-DMX module is installed in the fixture
		CRMX Mode	TX CRMX		Lumen Radio Mode, configurable via SPI, need to check correct register
			TX G4S		Wireless Solution G4S mode
			TX G3		Wireless Solution G3 mode
			RX		Generic receiver mode (will autoselect based on transmitter) (expects CRMX2, CRMX, G4S, G3)
		TX link receivers	Yes-No		TX link unlock when the unit is set as a transmitter
		TX unlink all receivers	Yes-No	Only in TX mode, Hidden if CRMX Mode=RX	Disconnect the transmitter from all receivers. TX unlink unlocks only if WDMX mode is on transmitter
		RX unlink receiver	Yes-No	Only in RX mode, Hidden if CRMX Mode=TX	
		Linking key (RX mode)	Set linking key	Insert 8 digit code	See Timo Two Documentation Linking Key Register containing Code, Mode and Universe to link to.
			Set linking mode	CRMX or CRMX ²	
			Set linking universe	CRMX: A,C,E,G CRMX?: A,B,C,D, E,F,G,H	
		Linking key (TX mode)	Set linking key	Insert 8 digit code	
		Use Bluetooth	Yes-No		Enable/Disable Bluetooth
	Set universe RGB Color	RGB Color set from R,G,B combo list	In TX CRMX Mode	In RX Mode values received from TX	
	Universe Name	first 16 characters of Model Name			
	CRMX status	Refer to status register on SPI			
	Software Version	Refer to software version			
CRMX Module	Refer to CRMX module				

2	SETUP	Light Control	Dimmer Speed	Auto		Set Dimmer Speed. This parameter defines interpolation of DMX Changes for main functions. Off turns off interpolation
				Slow		
				Medium		
				Fast		
				Off		
			Dimmer Curve	Linear		Choose dimmer curve.
				S-Curve		
				Square Law		
				Inverse square law		
				High Res @ Low		
			Tungsten Emulation	Use tungsten dimmer curve		
				Keep selected dimmer curve		
	Tungsten OFF					
	Color Space	Native		Define color space being used by fixture		
		ProPhoto RGB				
		sRGB				
		Rec. 2020				
	LED Mode	High Brightness				
		High Quality				
	Color Correction	On-Off				
	Fixture Control	Fan Mode	Auto		See table at the end of the Menu for Fan Modes behaviour	
			Turbo			
			Manual	0-100%		
Quiet 1 DLO						
Quiet 2 DLO						
OFF DLO						
Quiet 1 CLO						
Quiet 2 CLO						
OFF CLO						
Signal Fault Behaviour		Hold		Set the behaviour when Signal is lost. "Color Correction" should appear on the display only if Color Correction is set to ON		
		Hold - On Encoder Touch	CCT Mode			
			RGB Mode			
			HSI Mode			
			XY Mode			
			Gel Mode			
	Preset Mode					
	Color Correction					
Standalone						
Blackout						
Emergency						
Startup Behaviour	Hold		Set the behaviour when fixture is powered on without any signal			
	Hold - On Encoder Touch;	CCT Mode				
		RGB Mode				
		HSI Mode				
		XY Mode				

Voltages	U 48V
	U 12V
	U 5V
Calibration State	
Error messages	
Software Version	
CRMX Module	
RDM Id	
Documentation	

10 - RDM FUNCTIONS

The product can communicate using RDM (Remote Device Management) protocol over a DMX512 Networks.

RDM is a bi-directional communications protocol for use in DMX512 control systems, it is the open standard for DMX512 device configuration and status monitoring.

The RDM protocol allows data packets to be inserted into a DMX512 data stream without affecting existing non-RDM equipment. It allows a console or dedicated RDM controller to send commands to and receive messages from specific fixtures.

The PIDs in the following tables are supported in the product.

CATEGORY	PARAMETER	PID	GET	SET
Product Information	DEVICE_INFO	0x0060	x	
	DEVICE_MODEL_DESCRIPTION	0x0080	x	
	MANUFACTURER_LABEL	0x0081	x	
	DEVICE_LABEL	0x0082	x	x
	FACTORY_DEFAULTS	0x0090	x	x
	SOFTWARE_VERSION_LABEL	0x00C0	x	
DMX512 Setup	DMX_PERSONALITY	0x00E0	x	x
	DMX_PERSONALITY_DESCRIPTION	0x00E1	x	
	DMX_START_ADDRESS	0x00F0	x	x
Dimmer Settings	CURVE	0x0340	x	x
	CURVE_DESCRIPTION	0x0341	x	x
	MODULATION_FREQUENCY	0x0342	x	x
	MODULATION_FREQUENCY_DESCRIPTION	0x0343	x	
Sensors	SENSOR_DEFINITION	0x0200	x	
	SENSOR_VALUE	0x0201	x	x
Display Settings	DISPLAY_INVERT	0x0500	x	x
Control	IDENTIFY_DEVICE	0x1000	x	x
	FULL ON 0:HB Mode 1:Studio Mode	0x8217	x	x

DMX CHARTS

Model	RDM ID
ECLFRCTPS	D106
ECLFRCTPSIP	D132
ECLFRCTPM	D107
ECLFRCTPMIP	D109
ECLFRCTPL	D108
ECLFRCTPLIP	D110

RDM Personality ID List:

ID	DMX Mode	Footprint
1	UNO	1
2	DUO	2
3	BASIC	4
4	STANDARD	11
5	M2 - CCT 16 bit	11
6	M3 - RGB 8 bit	11
7	M4 - RGB 16 bit	15
8	M8 - XY 16 bit	17
9	M15 - CCT + RGB 8 bit	17
10	M16 - CCT + RGB 16 bit	21
11	M17 - CCT + RGB + GEL 8 bit	21
12	M18 - CCT + RGB + GEL 16 bit	25
13	M28 - CCT + XY 16 bit	17
14	M30 - CCT + XY + GEL 16 bit	21
15	M35 - RAW Control 8 bit	12
16	M36 - RAW Control 16 bit	19
17	M101 - PIXEL MAPPER MODE	3
18	M2 - CCT 16 bit + CC	20
19	M3 - RGB 8 bit + CC	20
20	M4 - RGB 16 bit + CC	24
21	M8 - XY 16 bit + CC	26
22	M15 - CCT + RGB 8 bit + CC	26
23	M16 - CCT + RGB 16 bit + CC	30
24	M17 - CCT + RGB + GEL 8 bit + CC	30
25	M18 - CCT + RGB + GEL 16 bit + CC	34
26	M28 - CCT + XY 16 bit + CC	26
27	M30 - CCT + XY + GEL 16 bit + CC	30

NOTE: The dmx modes marked with an asterisk (*) are only available if the Colour Correction mode is activated from the menu

Channel	UNO	DUE	BASIC	STANDARD	M101 - Pixel Mapper Mode	M2 - CCT 16 bit	M3 - RGB 8 bit
1	Dimmer	Dimmer	Dimmer	Dimmer	Red	Dimmer	Dimmer
2		Dimmer Fine	Red	Dimmer Fine	Green	Dimmer Fine	Red
3			Green	CCT	Blue	CCT	Green
4			Blue	CCT Fine		CCT Fine	Blue
5				GMP		GMP	White Point CCT
6				Crossfade from CCT to RGB		CCT Range Selector	White Point CCT FINE
7				Red		Strobe	Strobe
8				Green		Control	Control
9				Blue		Preset	Preset
10				Strobe		Fan Control	Fan Control
11				Control		RESERVED	RESERVED
12							
13							
14							
15							
16							
17							
18							
19							
20							
21							
22							
23							
24							
25							

Channel	M4 - RGB 16 bit	M8 - XY 16 bit	M15 - CCT + RGB 8 bit	M16 - CCT + RGB 16 bit	M17 - CCT + RGB + GEL 8 bit
1	Dimmer	Dimmer	Dimmer	Dimmer	Dimmer
2	Dimmer Fine	Dimmer Fine	CCT	Dimmer Fine	CCT
3	Red	X1	CCT Fine	CCT	CCT Fine
4	Red Fine	X1 Fine	GMP	CCT Fine	TINT
5	Green	Y1	Crossfade from CCT to RGB	GMP	Crossfade from CCT to RGB
6	Green Fine	Y1 Fine	Red	Crossfade from CCT to RGB	Red
7	Blue	Crossfade XY1 to XY2	Green	Red	Green
8	Blue Fine	X2	Blue	Red Fine	Blue
9	White Point CCT	X2 Fine	CCT Range Selector	Green	Crossfade from RGB to GEL
10	White Point CCT Fine	Y2	White Point CCT	Green Fine	Gel Source Lamp
11	Strobe	Y2 Fine	White Point CCT Fine	Blue	Gel Brand / Category
12	Control	Transition Type	Transition Type	Blue Fine	Gel Selector
13	Preset	Strobe	Strobe	CCT Range Selector	CCT Range Selector
14	Fan Control	Control	Control	White Point CCT	White Point CCT
15	RESERVED	Preset	Preset	White Point CCT Fine	White Point CCT Fine
16		Fan Control	Fan Control	Transition Type	Transition Type
17		RESERVED	RESERVED	Strobe	Strobe
18				Control	Control
19				Preset	Preset
20				Fan Control	Fan Control
21				RESERVED	RESERVED
22					
23					
24					
25					

Channel	M18 - CCT + RGB + GEL 16 bit	M28 - CCT + XY 16 bit	M30 - CCT + XY + GEL 16 bit	M35 - RAW Control 8 bit	M36 - RAW Control 16 bit
1	Dimmer	Dimmer	Dimmer	Dimmer	Dimmer
2	Dimmer Fine	Dimmer Fine	Dimmer Fine	Red	Dimmer Fine
3	CCT	CCT	CCT	Green	Red
4	CCT Fine	CCT Fine	CCT Fine	Blue	Red Fine
5	GMP	GMP	GMP	Cyan	Green
6	Crossfade from CCT to RGB	Crossfade	Crossfade	Mint	Green Fine
7	Red	X	X	Amber	Blue
8	Red Fine	X Fine	X Fine	Strobe	Blue Fine
9	Green	Y	Y	Control	Cyan
10	Green Fine	Y Fine	Y Fine	Preset	Cyan Fine
11	Blue	CCT Range Selector	Crossfade from RGB to GEL	Fan Control	Mint
12	Blue Fine	Transition Type	Gel Source Lamp	Reserved	Mint Fine
13	Crossfade from RGB to GEL	Strobe	Gel Brand / Category		Amber
14	Gel Source Lamp	Control	Gel Selector		Amber Fine
15	Gel Brand / Category	Preset	CCT Range Selector		Strobe
16	Gel Selector	Fan Control	Transition Type		Control
17	CCT Range Selector	RESERVED	Strobe		Preset
18	White Point CCT		Control		Fan Control
19	White Point CCT Fine		Preset		RESERVED
20	Transition Type		Fan Control		
21	Strobe		RESERVED		
22	Control				
23	Preset				
24	Fan Control				
25	RESERVED				

Below is the table with DMX modes available if the color correction mode is activated in the menu (which adds channels to implement color correction):

Channel	M2 - CCT 16 bit + CC	M3 - RGB 8 bit + CC	M4 - RGB 16 bit + CC	M8 - XY 16 bit + CC	M15 - CCT + RGB 8 bit + CC
1	Dimmer	Dimmer	Dimmer	Dimmer	Dimmer
2	Dimmer Fine	Red	Dimmer Fine	Dimmer Fine	CCT
3	CCT	Green	Red	X1	CCT Fine
4	CCT Fine	Blue	Red Fine	X1 Fine	GMP
5	GMP	White Point CCT	Green	Y1	Crossfade from CCT to RGB
6	CCT Range Selector	White Point CCT FINE	Green Fine	Y1 Fine	Red
7	Strobe	Strobe	Blue	Crossfade XY1 to XY2	Green
8	Control	Control	Blue Fine	X2	Blue
9	Preset	Preset	White Point CCT	X2 Fine	CCT Range Selector
10	Fan Control	Fan Control	White Point CCT Fine	Y2	White Point CCT
11	RESERVED	RESERVED	Strobe	Y2 Fine	White Point CCT Fine
12	CC Mode	CC Mode	Control	Transition Type	Transition Type
13	Cooler/Warmer	Cooler/Warmer	Preset	Strobe	Strobe
14	Saturate / Desaturate	Saturate / Desaturate	Fan Control	Control	Control
15	"CC Parameter 1 (±Red / ±Red)"	"CC Parameter 1 (±Red / ±Red)"	RESERVED	Preset	Preset
16	"CC Parameter 2 (±Green / ±Green)"	"CC Parameter 2 (±Green / ±Green)"	CC Mode	Fan Control	Fan Control
17	"CC Parameter 3 (±Blue / ±Blue)"	"CC Parameter 3 (±Blue / ±Blue)"	Cooler/Warmer	RESERVED	RESERVED
18	"CC Parameter 4 (±Cyan / ±Cyan)"	"CC Parameter 4 (±Cyan / ±Cyan)"	Saturate / Desaturate	CC Mode	CC Mode
19	"CC Parameter 5 (±Magenta / ±Mint)"	"CC Parameter 5 (±Magenta / ±Mint)"	"CC Parameter 1 (±Red / ±Red)"	Cooler/Warmer	Cooler/Warmer
20	"CC Parameter 6 (±Yellow / ±Amber)"	"CC Parameter 6 (±Yellow / ±Amber)"	"CC Parameter 2 (±Green / ±Green)"	Saturate / Desaturate	Saturate / Desaturate
21			"CC Parameter 3 (±Blue / ±Blue)"	"CC Parameter 1 (±Red / ±Red)"	"CC Parameter 1 (±Red / ±Red)"
22			"CC Parameter 4 (±Cyan / ±Cyan)"	"CC Parameter 2 (±Green / ±Green)"	"CC Parameter 2 (±Green / ±Green)"
23			"CC Parameter 5 (±Magenta / ±Mint)"	"CC Parameter 3 (±Blue / ±Blue)"	"CC Parameter 3 (±Blue / ±Blue)"
24			"CC Parameter 6 (±Yellow / ±Amber)"	"CC Parameter 4 (±Cyan / ±Cyan)"	"CC Parameter 4 (±Cyan / ±Cyan)"
25				"CC Parameter 5 (±Magenta / ±Mint)"	"CC Parameter 5 (±Magenta / ±Mint)"
26				"CC Parameter 6 (±Yellow / ±Amber)"	"CC Parameter 6 (±Yellow / ±Amber)"

Channel	M16 - CCT + RGB 16 bit + CC	M17 - CCT + RGB + GEL 8 bit + CC	M18 - CCT + RGB + GEL 16 bit + CC	M28 - CCT + XY 16 bit + CC	M30 - CCT + XY + GEL 16 bit + CC
1	Dimmer	Dimmer	Dimmer	Dimmer	Dimmer
2	Dimmer Fine	CCT	Dimmer Fine	Dimmer Fine	Dimmer Fine
3	CCT	CCT Fine	CCT	CCT	CCT
4	CCT Fine	TINT	CCT Fine	CCT Fine	CCT Fine
5	GMP	Crossfade from CCT to RGB	GMP	GMP	GMP
6	Crossfade from CCT to RGB	Red	Crossfade from CCT to RGB	Crossfade	Crossfade
7	Red	Green	Red	X	X
8	Red Fine	Blue	Red Fine	X Fine	X Fine
9	Green	Crossfade from RGB to GEL	Green	Y	Y
10	Green Fine	Gel Source Lamp	Green Fine	Y Fine	Y Fine
11	Blue	Gel Brand / Category	Blue	CCT Range Selector	Crossfade from RGB to GEL
12	Blue Fine	Gel Selector	Blue Fine	Transition Type	Gel Source Lamp
13	CCT Range Selector	CCT Range Selector	Crossfade from RGB to GEL	Strobe	Gel Brand / Category
14	White Point CCT	White Point CCT	Gel Source Lamp	Control	Gel Selector
15	White Point CCT Fine	White Point CCT Fine	Gel Brand / Category	Preset	CCT Range Selector
16	Transition Type	Transition Type	Gel Selector	Fan Control	Transition Type
17	Strobe	Strobe	CCT Range Selector	RESERVED	Strobe
18	Control	Control	White Point CCT	CC Mode	Control
19	Preset	Preset	White Point CCT Fine	Cooler/Warmer	Preset
20	Fan Control	Fan Control	Transition Type	Saturate / Desaturate	Fan Control
21	RESERVED	RESERVED	Strobe	"CC Parameter 1 (±Red / ±Red)"	RESERVED
22	CC Mode	CC Mode	Control	"CC Parameter 2 (±Green / ±Green)"	CC Mode
23	Cooler/Warmer	Cooler/Warmer	Preset	"CC Parameter 3 (±Blue / ±Blue)"	Cooler/Warmer
24	Saturate / Desaturate	Saturate / Desaturate	Fan Control	" CC Parameter 4 (±Cyan / ±Cyan)"	Saturate / Desaturate
25	"CC Parameter 1 (±Red / ±Red)"	"CC Parameter 1 (±Red / ±Red)"	RESERVED	"CC Parameter 5 (±Magenta / ±Mint)"	"CC Parameter 1 (±Red / ±Red)"
26	"CC Parameter 2 (±Green / ±Green)"	"CC Parameter 2 (±Green / ±Green)"	CC Mode	"CC Parameter 6 (±Yellow / ±Amber)"	"CC Parameter 2 (±Green / ±Green)"
27	"CC Parameter 3 (±Blue / ±Blue)"	"CC Parameter 3 (±Blue / ±Blue)"	Cooler/Warmer		"CC Parameter 3 (±Blue / ±Blue)"
28	" CC Parameter 4 (±Cyan / ±Cyan)"	" CC Parameter 4 (±Cyan / ±Cyan)"	Saturate / Desaturate		" CC Parameter 4 (±Cyan / ±Cyan)"
29	"CC Parameter 5 (±Magenta / ±Mint)"	"CC Parameter 5 (±Magenta / ±Mint)"	"CC Parameter 1 (±Red / ±Red)"		"CC Parameter 5 (±Magenta / ±Mint)"
30	"CC Parameter 6 (±Yellow / ±Amber)"	"CC Parameter 6 (±Yellow / ±Amber)"	"CC Parameter 2 (±Green / ±Green)"		"CC Parameter 6 (±Yellow / ±Amber)"
31			"CC Parameter 3 (±Blue / ±Blue)"		
32			" CC Parameter 4 (±Cyan / ±Cyan)"		
33			"CC Parameter 5 (±Magenta / ±Mint)"		
34			"CC Parameter 6 (±Yellow / ±Amber)"		

CHANNEL DEFINITION

Dimmer

Function	8 bit value		16 bit value		Note
	From	To	From	To	
Dimmer	0	255	0	65535	Default @ 0 (Linear Dimmer 0 - 100%)

Dimmer Fine

Function	8 bit value		16 bit value		Note
	From	To	From	To	
Dimmer Fine	0	255	0	65535	Default @ 0 (Linear Dimmer 0 - 100%)

CCT Range Selector

Function		8 bit value		16 bit value		Note
CCT(K) From	CCT(K) To	From	To	From	To	
1850K	2000K	0	9			Default @ 0 (Linear from 1850K to 2000K)
2200K	15000K	10	19			
2800K	10000K	20	29			
Reserved		30	255			

CCT (When CCT Range Selector @ 1850K - 20000K)

Function		8 bit value		16 bit value		Note
CCT(K) From	CCT(K) To	From	To	From	To	
1850	1900	0	1	0	181	Default @ 0
1900	2000	1	2	181	542	
2000	2100	2	4	542	903	
2100	2200	4	5	903	1264	
2200	2300	5	6	1264	1625	
2300	2400	6	8	1625	1986	
2400	2500	8	9	1986	2347	
2500	2600	9	11	2347	2708	
2600	2700	11	12	2708	3069	
2700	2800	12	13	3069	3430	
2800	2900	13	15	3430	3791	
2900	3000	15	16	3791	4152	
3000	3100	16	18	4152	4513	
3100	3200	18	19	4513	4875	
3200	3300	19	20	4875	5236	
3300	3400	20	22	5236	5597	
3400	3500	22	23	5597	5958	
3500	3600	23	25	5958	6319	
3600	3700	25	26	6319	6680	
3700	3800	26	27	6680	7041	
3800	3900	27	29	7041	7402	
3900	4000	29	30	7402	7763	
4000	4100	30	32	7763	8124	

CCT (When CCT Range Selector @ 1850K - 20000K)

Function		8 bit value		16 bit value		Note
CCT(K) From	CCT(K) To	From	To	From	To	
4100	4200	32	33	8124	8485	
4200	4300	33	34	8485	8846	
4300	4400	34	36	8846	9207	
4400	4500	36	37	9207	9568	
4500	4600	37	39	9568	9930	
4600	4700	39	40	9930	10291	
4700	4800	40	41	10291	10652	
4800	4900	41	43	10652	11013	
4900	5000	43	44	11013	11374	
5000	5100	44	46	11374	11735	
5100	5200	46	47	11735	12096	
5200	5300	47	48	12096	12457	
5300	5400	48	50	12457	12818	
5400	5500	50	51	12818	13179	
5500	5600	51	53	13179	13540	
5600	5700	53	54	13540	13901	
5700	5800	54	55	13901	14262	
5800	5900	55	57	14262	14624	
5900	6000	57	58	14624	14985	
6000	6100	58	60	14985	15346	
6100	6200	60	61	15346	15707	
6200	6300	61	63	15707	16068	
6300	6400	63	64	16068	16429	
6400	6500	64	65	16429	16790	
6500	6600	65	67	16790	17151	
6600	6700	67	68	17151	17512	
6700	6800	68	70	17512	17873	
6800	6900	70	71	17873	18234	
6900	7000	71	72	18234	18595	
7000	7100	72	74	18595	18956	
7100	7200	74	75	18956	19317	
7200	7300	75	77	19317	19679	
7300	7400	77	78	19679	20040	
7400	7500	78	79	20040	20401	
7500	7600	79	81	20401	20762	
7600	7700	81	82	20762	21123	
7700	7800	82	84	21123	21484	
7800	7900	84	85	21484	21845	
7900	8000	85	86	21845	22206	
8000	8100	86	88	22206	22567	
8100	8200	88	89	22567	22928	
8200	8300	89	91	22928	23289	
8300	8400	91	92	23289	23650	
8400	8500	92	93	23650	24011	
8500	8600	93	95	24011	24373	
8600	8700	95	96	24373	24734	
8700	8800	96	98	24734	25095	
8800	8900	98	99	25095	25456	
8900	9000	99	100	25456	25817	
9000	9100	100	102	25817	26178	
9100	9200	102	103	26178	26539	

CCT (When CCT Range Selector @ 1850K - 20000K)

Function		8 bit value		16 bit value		Note
CCT(K) From	CCT(K) To	From	To	From	To	
9200	9300	103	105	26539	26900	
9300	9400	105	106	26900	27261	
9400	9500	106	107	27261	27622	
9500	9600	107	109	27622	27983	
9600	9700	109	110	27983	28344	
9700	9800	110	112	28344	28705	
9800	9900	112	113	28705	29066	
9900	10000	113	115	29066	29428	
10000	10100	115	116	29428	29789	
10100	10200	116	117	29789	30150	
10200	10300	117	119	30150	30511	
10300	10400	119	120	30511	30872	
10400	10500	120	122	30872	31233	
10500	10600	122	123	31233	31594	
10600	10700	123	124	31594	31955	
10700	10800	124	126	31955	32316	
10800	10900	126	127	32316	32677	
10900	11000	127	129	32677	33038	
11000	11100	129	130	33038	33399	
11100	11200	130	131	33399	33760	
11200	11300	131	133	33760	34122	
11300	11400	133	134	34122	34483	
11400	11500	134	136	34483	34844	
11500	11600	136	137	34844	35205	
11600	11700	137	138	35205	35566	
11700	11800	138	140	35566	35927	
11800	11900	140	141	35927	36288	
11900	12000	141	143	36288	36649	
12000	12100	143	144	36649	37010	
12100	12200	144	145	37010	37371	
12200	12300	145	147	37371	37732	
12300	12400	147	148	37732	38093	
12400	12500	148	150	38093	38454	
12500	12600	150	151	38454	38815	
12600	12700	151	152	38815	39177	
12700	12800	152	154	39177	39538	
12800	12900	154	155	39538	39899	
12900	13000	155	157	39899	40260	
13000	13100	157	158	40260	40621	
13100	13200	158	159	40621	40982	
13200	13300	159	161	40982	41343	
13300	13400	161	162	41343	41704	
13400	13500	162	164	41704	42065	
13500	13600	164	165	42065	42426	
13600	13700	165	166	42426	42787	
13700	13800	166	168	42787	43148	
13800	13900	168	169	43148	43509	
13900	14000	169	171	43509	43871	
14000	14100	171	172	43871	44232	
14100	14200	172	174	44232	44593	
14200	14300	174	175	44593	44954	

CCT (When CCT Range Selector @ 1850K - 20000K)

Function		8 bit value		16 bit value		Note
CCT(K) From	CCT(K) To	From	To	From	To	
14300	14400	175	176	44954	45315	
14400	14500	176	178	45315	45676	
14500	14600	178	179	45676	46037	
14600	14700	179	181	46037	46398	
14700	14800	181	182	46398	46759	
14800	14900	182	183	46759	47120	
14900	15000	183	185	47120	47481	
15000	15100	185	186	47481	47842	
15100	15200	186	188	47842	48203	
15200	15300	188	189	48203	48565	
15300	15400	189	190	48565	48926	
15400	15500	190	192	48926	49287	
15500	15600	192	193	49287	49648	
15600	15700	193	195	49648	50009	
15700	15800	195	196	50009	50370	
15800	15900	196	197	50370	50731	
15900	16000	197	199	50731	51092	
16000	16100	199	200	51092	51453	
16100	16200	200	202	51453	51814	
16200	16300	202	203	51814	52175	
16300	16400	203	204	52175	52536	
16400	16500	204	206	52536	52897	
16500	16600	206	207	52897	53258	
16600	16700	207	209	53258	53620	
16700	16800	209	210	53620	53981	
16800	16900	210	211	53981	54342	
16900	17000	211	213	54342	54703	
17000	17100	213	214	54703	55064	
17100	17200	214	216	55064	55425	
17200	17300	216	217	55425	55786	
17300	17400	217	218	55786	56147	
17400	17500	218	220	56147	56508	
17500	17600	220	221	56508	56869	
17600	17700	221	223	56869	57230	
17700	17800	223	224	57230	57591	
17800	17900	224	225	57591	57952	
17900	18000	225	227	57952	58314	
18000	18100	227	228	58314	58675	
18100	18200	228	230	58675	59036	
18200	18300	230	231	59036	59397	
18300	18400	231	233	59397	59758	
18400	18500	233	234	59758	60119	
18500	18600	234	235	60119	60480	
18600	18700	235	237	60480	60841	
18700	18800	237	238	60841	61202	
18800	18900	238	240	61202	61563	
18900	19000	240	241	61563	61924	
19000	19100	241	242	61924	62285	
19100	19200	242	244	62285	62646	
19200	19300	244	245	62646	63007	
19300	19400	245	247	63007	63369	

CCT (When CCT Range Selector @ 1850K - 20000K)

Function		8 bit value		16 bit value		Note
CCT(K) From	CCT(K) To	From	To	From	To	
19400	19500	247	248	63369	63730	
19500	19600	248	249	63730	64091	
19600	19700	249	251	64091	64452	
19700	19800	251	252	64452	64813	
19800	19900	252	254	64813	65174	
19900	20000	254	255	65174	65535	

CCT (When CCT Range Selector @ 2200K - 15000K)

Function		8 bit value		16 bit value		Note
CCT(K) From	CCT(K) To	From	To	From	To	
2200	2300	0	2	0	512	Default @ 0
2300	2400	2	4	512	1024	
2400	2500	4	6	1024	1536	
2500	2600	6	8	1536	2048	
2600	2700	8	10	2048	2560	
2700	2800	10	12	2560	3072	
2800	2900	12	14	3072	3584	
2900	3000	14	16	3584	4096	
3000	3100	16	18	4096	4608	
3100	3200	18	20	4608	5120	
3200	3300	20	22	5120	5632	
3300	3400	22	24	5632	6144	
3400	3500	24	26	6144	6656	
3500	3600	26	28	6656	7168	
3600	3700	28	30	7168	7680	
3700	3800	30	32	7680	8192	
3800	3900	32	34	8192	8704	
3900	4000	34	36	8704	9216	
4000	4100	36	38	9216	9728	
4100	4200	38	40	9728	10240	
4200	4300	40	42	10240	10752	
4300	4400	42	44	10752	11264	
4400	4500	44	46	11264	11776	
4500	4600	46	48	11776	12288	
4600	4700	48	50	12288	12800	
4700	4800	50	52	12800	13312	

CCT (When CCT Range Selector @ 2200K - 15000K)

Function		8 bit value		16 bit value		Note
CCT(K) From	CCT(K) To	From	To	From	To	
4800	4900	52	54	13312	13824	
4900	5000	54	56	13824	14336	
5000	5100	56	58	14336	14848	
5100	5200	58	60	14848	15360	
5200	5300	60	62	15360	15872	
5300	5400	62	64	15872	16384	
5400	5500	64	66	16384	16896	
5500	5600	66	68	16896	17408	
5600	5700	68	70	17408	17920	
5700	5800	70	72	17920	18432	
5800	5900	72	74	18432	18944	
5900	6000	74	76	18944	19456	
6000	6100	76	78	19456	19968	
6100	6200	78	80	19968	20480	
6200	6300	80	82	20480	20992	
6300	6400	82	84	20992	21504	
6400	6500	84	86	21504	22016	
6500	6600	86	88	22016	22528	
6600	6700	88	90	22528	23040	
6700	6800	90	92	23040	23552	
6800	6900	92	94	23552	24064	
6900	7000	94	96	24064	24576	
7000	7100	96	98	24576	25088	
7100	7200	98	100	25088	25600	
7200	7300	100	102	25600	26112	
7300	7400	102	104	26112	26624	
7400	7500	104	106	26624	27136	
7500	7600	106	108	27136	27648	
7600	7700	108	110	27648	28160	
7700	7800	110	112	28160	28672	
7800	7900	112	114	28672	29184	
7900	8000	114	116	29184	29696	
8000	8100	116	118	29696	30208	
8100	8200	118	120	30208	30720	
8200	8300	120	122	30720	31232	
8300	8400	122	124	31232	31744	
8400	8500	124	126	31744	32256	
8500	8600	126	128	32256	32768	
8600	8700	128	129	32768	33279	
8700	8800	129	131	33279	33791	
8800	8900	131	133	33791	34303	
8900	9000	133	135	34303	34815	
9000	9100	135	137	34815	35327	
9100	9200	137	139	35327	35839	
9200	9300	139	141	35839	36351	
9300	9400	141	143	36351	36863	
9400	9500	143	145	36863	37375	
9500	9600	145	147	37375	37887	
9600	9700	147	149	37887	38399	
9700	9800	149	151	38399	38911	
9800	9900	151	153	38911	39423	

CCT (When CCT Range Selector @ 2200K - 15000K)

Function		8 bit value		16 bit value		Note
CCT(K) From	CCT(K) To	From	To	From	To	
9900	10000	153	155	39423	39935	
10000	10100	155	157	39935	40447	
10100	10200	157	159	40447	40959	
10200	10300	159	161	40959	41471	
10300	10400	161	163	41471	41983	
10400	10500	163	165	41983	42495	
10500	10600	165	167	42495	43007	
10600	10700	167	169	43007	43519	
10700	10800	169	171	43519	44031	
10800	10900	171	173	44031	44543	
10900	11000	173	175	44543	45055	
11000	11100	175	177	45055	45567	
11100	11200	177	179	45567	46079	
11200	11300	179	181	46079	46591	
11300	11400	181	183	46591	47103	
11400	11500	183	185	47103	47615	
11500	11600	185	187	47615	48127	
11600	11700	187	189	48127	48639	
11700	11800	189	191	48639	49151	
11800	11900	191	193	49151	49663	
11900	12000	193	195	49663	50175	
12000	12100	195	197	50175	50687	
12100	12200	197	199	50687	51199	
12200	12300	199	201	51199	51711	
12300	12400	201	203	51711	52223	
12400	12500	203	205	52223	52735	
12500	12600	205	207	52735	53247	
12600	12700	207	209	53247	53759	
12700	12800	209	211	53759	54271	
12800	12900	211	213	54271	54783	
12900	13000	213	215	54783	55295	
13000	13100	215	217	55295	55807	
13100	13200	217	219	55807	56319	
13200	13300	219	221	56319	56831	
13300	13400	221	223	56831	57343	
13400	13500	223	225	57343	57855	
13500	13600	225	227	57855	58367	
13600	13700	227	229	58367	58879	
13700	13800	229	231	58879	59391	
13800	13900	231	233	59391	59903	
13900	14000	233	235	59903	60415	
14000	14100	235	237	60415	60927	
14100	14200	237	239	60927	61439	
14200	14300	239	241	61439	61951	
14300	14400	241	243	61951	62463	
14400	14500	243	245	62463	62975	
14500	14600	245	247	62975	63487	
14600	14700	247	249	63487	63999	
14700	14800	249	251	63999	64511	
14800	14900	251	253	64511	65023	
14900	15000	253	255	65023	65535	

CCT (When CCT Range Selector @ 2800K - 10000K)

Function		8 bit value		16 bit value		Note
CCT(K) From	CCT(K) To	From	To	From	To	
2800	2900	0	4	0	910	Default @ 0
2900	3000	4	7	910	1820	
3000	3100	7	11	1820	2731	
3100	3200	11	14	2731	3641	
3200	3300	14	18	3641	4551	
3300	3400	18	21	4551	5461	
3400	3500	21	25	5461	6371	
3500	3600	25	28	6371	7282	
3600	3700	28	32	7282	8192	
3700	3800	32	35	8192	9102	
3800	3900	35	39	9102	10012	
3900	4000	39	43	10012	10923	
4000	4100	43	46	10923	11833	
4100	4200	46	50	11833	12743	
4200	4300	50	53	12743	13653	
4300	4400	53	57	13653	14563	
4400	4500	57	60	14563	15474	
4500	4600	60	64	15474	16384	
4600	4700	64	67	16384	17294	
4700	4800	67	71	17294	18204	
4800	4900	71	74	18204	19114	
4900	5000	74	78	19114	20025	
5000	5100	78	81	20025	20935	
5100	5200	81	85	20935	21845	
5200	5300	85	89	21845	22755	
5300	5400	89	92	22755	23665	
5400	5500	92	96	23665	24576	
5500	5600	96	99	24576	25486	
5600	5700	99	103	25486	26396	
5700	5800	103	106	26396	27306	
5800	5900	106	110	27306	28216	
5900	6000	110	113	28216	29127	
6000	6100	113	117	29127	30037	
6100	6200	117	120	30037	30947	
6200	6300	120	124	30947	31857	
6300	6400	124	128	31857	32768	
6400	6500	128	131	32768	33678	
6500	6600	131	135	33678	34588	
6600	6700	135	138	34588	35498	
6700	6800	138	142	35498	36408	
6800	6900	142	145	36408	37319	
6900	7000	145	149	37319	38229	
7000	7100	149	152	38229	39139	
7100	7200	152	156	39139	40049	
7200	7300	156	159	40049	40959	
7300	7400	159	163	40959	41870	
7400	7500	163	166	41870	42780	
7500	7600	166	170	42780	43690	
7600	7700	170	174	43690	44600	
7700	7800	174	177	44600	45510	

CCT (When CCT Range Selector @ 2800K - 10000K)

Function		8 bit value		16 bit value		Note
CCT(K) From	CCT(K) To	From	To	From	To	
7800	7900	177	181	45510	46421	
7900	8000	181	184	46421	47331	
8000	8100	184	188	47331	48241	
8100	8200	188	191	48241	49151	
8200	8300	191	195	49151	50061	
8300	8400	195	198	50061	50972	
8400	8500	198	202	50972	51882	
8500	8600	202	205	51882	52792	
8600	8700	205	209	52792	53702	
8700	8800	209	213	53702	54613	
8800	8900	213	216	54613	55523	
8900	9000	216	220	55523	56433	
9000	9100	220	223	56433	57343	
9100	9200	223	227	57343	58253	
9200	9300	227	230	58253	59164	
9300	9400	230	234	59164	60074	
9400	9500	234	237	60074	60984	
9500	9600	237	241	60984	61894	
9600	9700	241	244	61894	62804	
9700	9800	244	248	62804	63715	
9800	9900	248	251	63715	64625	
9900	10000	251	255	64625	65535	

CCT Fine

Function		8 bit value		16 bit value		Note
CCT(K) From	CCT(K) To	From	To	From	To	
2800K	10000K	0	255	0	65535	Default @ 0 Range dependent CCT range selector
2200K	15000K					
1850K	20000K					

Green Magenta Poin Channel (GMP)

Function	8 bit value		16 bit value		Note
	From	To	From	To	
Neutral / No Effect	0	1	0	511	Default @ 128 (8bit) / 32768 (16bit) Linear tint correction from -0.025 to +0.025
Full Minus Green	2	3	512	1023	
-99% to -1%	4	126	1024	32511	
Neutral / No Effect	127	128	32512	33023	
1% to 99%	129	253	33024	65023	
Full Plus Green	254	255	65024	65535	

Crossfade from CCT to RGB

Function	8 bit value		16 bit value		Note
	From	To	From	To	
Crossfade from CCT to RGB	0	255	0	65535	Default @ 0 Linear Crossfade from CCT to RGB

Red

Function	8 bit value		16 bit value		Note
	From	To	From	To	
Red	0	255	0	65535	Default @ 255 (8bit) / 65535 (16bit)

Red Fine

Function	8 bit value		16 bit value		Note
	From	To	From	To	
Red Fine	0	255	0	65535	Default @ 255 (8bit) / 65535 (16bit)

Green

Function	8 bit value		16 bit value		Note
	From	To	From	To	
Green	0	255	0	65535	Default @ 255 (8bit) / 65535 (16bit)

Green Fine

Function	8 bit value		16 bit value		Note
	From	To	From	To	
Green Fine	0	255	0	65535	Default @ 255 (8bit) / 65535 (16bit)

Blue

Function	8 bit value		16 bit value		Note
	From	To	From	To	
Blue	0	255	0	65535	Default @ 255 (8bit) / 65535 (16bit)

Blue Fine

Function	8 bit value		16 bit value		Note
	From	To	From	To	
Blue Fine	0	255	0	65535	Default @ 255 (8bit) / 65535 (16bit)

Cyan

Function	8 bit value		16 bit value		Note
	From	To	From	To	
Cyan	0	255	0	65535	Default @ 255 (8bit) / 65535 (16bit)

Cyan Fine

Function	8 bit value		16 bit value		Note
	From	To	From	To	
Cyan Fine	0	255	0	65535	Default @ 255 (8bit) / 65535 (16bit)

Mint

Function	8 bit value		16 bit value		Note
	From	To	From	To	
Mint	0	255	0	65535	Default @ 255 (8bit) / 65535 (16bit)

Mint Fine

Function	8 bit value		16 bit value		Note
	From	To	From	To	
Mint Fine	0	255	0	65535	Default @ 255 (8bit) / 65535 (16bit)

Amber

Function	8 bit value		16 bit value		Note
	From	To	From	To	
Amber	0	255	0	65535	Default @ 255 (8bit) / 65535 (16bit)

Amber Fine

Function	8 bit value		16 bit value		Note
	From	To	From	To	
Amber Fine	0	255	0	65535	Default @ 255 (8bit) / 65535 (16bit)

White Point Selector (8bit)

Function	8 bit value		16 bit value		Note
	From	To	From	To	
Default	0	1	0	511	Default @ 0, From Color Space Definition on the device
Dynamic	2	255	512	65535	2800K - 10000K

White Point Selector Fine

Function	8 bit value		16 bit value		Note
	From	To	From	To	
White Point Selector Fine	0	255	0	65535	Default @ 0

Dynamic White Point 2800K - 10000K

Function		8 bit value		16 bit value		Note
CCT(K) From	CCT(K) To	From	To	From	To	
2800	2900	2	6	512	1415	Default @ 0
2900	3000	6	9	1415	2318	
3000	3100	9	13	2318	3221	
3100	3200	13	16	3221	4124	
3200	3300	16	20	4124	5027	
3300	3400	20	23	5027	5931	
3400	3500	23	27	5931	6834	
3500	3600	27	30	6834	7737	
3600	3700	30	34	7737	8640	
3700	3800	34	37	8640	9543	
3800	3900	37	41	9543	10446	
3900	4000	41	44	10446	11349	
4000	4100	44	48	11349	12252	
4100	4200	48	51	12252	13155	
4200	4300	51	55	13155	14058	
4300	4400	55	58	14058	14962	
4400	4500	58	62	14962	15865	
4500	4600	62	65	15865	16768	
4600	4700	65	69	16768	17671	
4700	4800	69	72	17671	18574	
4800	4900	72	76	18574	19477	
4900	5000	76	79	19477	20380	
5000	5100	79	83	20380	21283	
5100	5200	83	86	21283	22186	
5200	5300	86	90	22186	23089	
5300	5400	90	93	23089	23993	
5400	5500	93	97	23993	24896	
5500	5600	97	100	24896	25799	

Dynamic White Point 2800K - 10000K

Function		8 bit value		16 bit value		Note
CCT(K) From	CCT(K) To	From	To	From	To	
5600	5700	100	104	25799	26702	
5700	5800	104	107	26702	27605	
5800	5900	107	111	27605	28508	
5900	6000	111	114	28508	29411	
6000	6100	114	118	29411	30314	
6100	6200	118	121	30314	31217	
6200	6300	121	125	31217	32120	
6300	6400	125	129	32120	33024	
6400	6500	129	132	33024	33927	
6500	6600	132	136	33927	34830	
6600	6700	136	139	34830	35733	
6700	6800	139	143	35733	36636	
6800	6900	143	146	36636	37539	
6900	7000	146	150	37539	38442	
7000	7100	150	153	38442	39345	
7100	7200	153	157	39345	40248	
7200	7300	157	160	40248	41151	
7300	7400	160	164	41151	42054	
7400	7500	164	167	42054	42958	
7500	7600	167	171	42958	43861	
7600	7700	171	174	43861	44764	
7700	7800	174	178	44764	45667	
7800	7900	178	181	45667	46570	
7900	8000	181	185	46570	47473	
8000	8100	185	188	47473	48376	
8100	8200	188	192	48376	49279	
8200	8300	192	195	49279	50182	
8300	8400	195	199	50182	51085	
8400	8500	199	202	51085	51989	
8500	8600	202	206	51989	52892	
8600	8700	206	209	52892	53795	
8700	8800	209	213	53795	54698	
8800	8900	213	216	54698	55601	
8900	9000	216	220	55601	56504	
9000	9100	220	223	56504	57407	
9100	9200	223	227	57407	58310	
9200	9300	227	230	58310	59213	
9300	9400	230	234	59213	60116	
9400	9500	234	237	60116	61020	
9500	9600	237	241	61020	61923	
9600	9700	241	244	61923	62826	
9700	9800	244	248	62826	63729	
9800	9900	248	251	63729	64632	
9900	10000	251	255	64632	65535	

Crossfade from RGB to GEL

Function	8 bit value		16 bit value		Note
	From	To	From	To	
Crossfade from RGB to GEL	0	255	0	65535	Default @ 0 Linear Crossfade from RGB to GEL

Gel Source Lamp CCT

Function	8 bit value		16 bit value		Note
	From	To	From	To	
2700K	0	9	-	-	Default @ 0
2800K	10	19	-	-	
3000K	20	29	-	-	
3200K	30	39	-	-	
4000K	40	49	-	-	
5000K	50	59	-	-	
5600K	60	69	-	-	
6500K	70	79	-	-	
Reserved	80	255	-	-	

GEL Brand / Category Selector

Function	8 bit value		16 bit value		Note
	From	To	From	To	
LEE: Color correction	0	9	-	-	Default @ 0
LEE:Color Filters	10	19	-	-	
LEE: 600 Series	20	29	-	-	
LEE: Cosmetic Filters	30	39	-	-	
LEE: 700 Series	40	49	-	-	
RC: Color correction	50	59	-	-	
RC: CalC	60	69	-	-	
RC: StSelect	70	79	-	-	
RC: C-Lux	80	89	-	-	
Blackout	90	99	-	-	
Reserved	100	255	-	-	

Category | Lee: Color Correction

Function Gel Name	8 bit value		16 bit value		Gel Number
	From	To	From	To	
Double CTB	0	1	-	-	200
Full CTB	2	3	-	-	201
3/4 CTB	4	5	-	-	281
1/2 CTB	6	7	-	-	202
1/4 CTB	8	9	-	-	203
1/8 CTB	10	11	-	-	218
Double CTO	12	13	-	-	287
Full CTO	14	15	-	-	204
3/4 CTO	16	17	-	-	285
1/2 CTO	18	19	-	-	205
1/4 CTO	20	21	-	-	206
1/8 CTO	22	23	-	-	223
1 1/2 CTB	24	25	-	-	283
1 1/2 CTO	26	27	-	-	286
Full CTS	28	29	-	-	441
1/2 CTS	30	31	-	-	442
1/4 CTS	32	33	-	-	443
1/8 CTS	34	35	-	-	444
Full CTO + .3 ND	36	37	-	-	207
Full CTO + .6 ND	38	39	-	-	208
L.C.T. Yellow (Y1)	40	41	-	-	212
White Flame Green	42	43	-	-	213
LEE Fluorescent Green	44	45	-	-	219
Super Correction L.C.T. Yellow	46	47	-	-	230
Super Correction W.F. Green	48	49	-	-	232
H.M.I. (to Tungsten)	50	51	-	-	236
C.I.D. (to Tungsten)	52	53	-	-	237
C.S.I. (to Tungsten)	54	55	-	-	238
LEE Fluorescent 5700 Kelvin	56	57	-	-	241
LEE Fluorescent 4300 Kelvin	58	59	-	-	242
LEE Fluorescent 3600 Kelvin	60	61	-	-	243
LEE Plus Green	62	63	-	-	244
1/2 Plus Green	64	65	-	-	245
1/4 Plus Green	66	67	-	-	246
1/8 Plus Green	68	69	-	-	278
Lee Minus Green	70	71	-	-	247
1/2 Minus Green	72	73	-	-	248
1/4 Minus Green	74	75	-	-	249
1/8 Minus Green	76	77	-	-	279
Blackout	78	79	-	-	-
Reserved for Future Use	80	255	-	-	-

Category | Lee: Color Filters

Function Gel Name	8 bit value		16 bit value		Gel Number
	From	To	From	To	
Rose Pink	0	1	-	-	2
Lavender Tint	2	3	-	-	3
Medium Bastard Amber	4	5	-	-	4
Pale Yellow	6	7	-	-	7
Dark Salmon	8	9	-	-	8
Pale Amber Gold	10	11	-	-	9
Medium Yellow	12	13	-	-	10
Straw Tint	14	15	-	-	13
Surprise Peach	16	17	-	-	17
Fire	18	19	-	-	19
Medium Amber	20	21	-	-	20
Gold Amber	22	23	-	-	21
Dark Amber	24	25	-	-	22
Scarlet	26	27	-	-	24
Sunset Red	28	29	-	-	25
Bright Red	30	31	-	-	26
Light Pink	32	33	-	-	35
Medium Pink	34	35	-	-	36
Dark Magenta	36	37	-	-	46
Rose Purple	38	39	-	-	48
Light Lavender	40	41	-	-	52
Paler Lavender	42	43	-	-	53
Lavender	44	45	-	-	58
Mist Blue	46	47	-	-	61
Pale Blue	48	49	-	-	63
Sky Blue	50	51	-	-	68
Evening Blue	52	53	-	-	75
Just Blue	54	55	-	-	79
Deeper Blue	56	57	-	-	85
Lime Green	58	59	-	-	88
Moss Green	60	61	-	-	89
Dark Yellow Green	62	63	-	-	90
Spring Yellow	64	65	-	-	100
Yellow	66	67	-	-	101
Light Amber	68	69	-	-	102
Straw	70	71	-	-	103
Deep Amber	72	73	-	-	104
Primary Red	74	75	-	-	106
Light Rose	76	77	-	-	107
English Rose	78	79	-	-	108
Light Salmon	80	81	-	-	109
Middle Rose	82	83	-	-	110
Dark Pink	84	85	-	-	111
Magenta	86	87	-	-	113
Peacock Blue	88	89	-	-	115
Steel Blue	90	91	-	-	117
Light Blue	92	93	-	-	118
Deep Blue	94	95	-	-	120
LEE Green	96	97	-	-	121
Fern Green	98	99	-	-	122
Dark Green	100	101	-	-	124

Category | Lee: Color Filters

Function Gel Name	8 bit value		16 bit value		Gel Number
	From	To	From	To	
Smokey Pink	102	103	-	-	127
Bright Pink	104	105	-	-	128
Marine Blue	106	107	-	-	131
Golden Amber	108	109	-	-	134
Deep Golden Amber	110	111	-	-	135
Pale Lavender	112	113	-	-	136
Special Lavender	114	115	-	-	137
Pale Green	116	117	-	-	138
Summer Blue	118	119	-	-	140
Pale Violet	120	121	-	-	142
Pale Navy Blue	122	123	-	-	143
No Color Blue	124	125	-	-	144
Apricot	126	127	-	-	147
Bright Rose	128	129	-	-	148
Gold Tint	130	131	-	-	151
Pale Gold	132	133	-	-	152
Pale Salmon	134	135	-	-	153
Pale Rose	136	137	-	-	154
Chocolate	138	139	-	-	156
Pink	140	141	-	-	157
No Color Straw	142	143	-	-	159
Slate Blue	144	145	-	-	161
Bastard Amber	146	147	-	-	162
Flame Red	148	149	-	-	164
Daylight Blue	150	151	-	-	165
Lilac Tint	152	153	-	-	169
Deep Lavender	154	155	-	-	170
Dark Steel Blue	156	157	-	-	174
Loving Amber	158	159	-	-	176
Dark Lavender	160	161	-	-	180
Light Red	162	163	-	-	182
Flesh Pink	164	165	-	-	192
Surprise Pink	166	167	-	-	194
Zenith Blue	168	169	-	-	195
True Blue	170	171	-	-	196
Alice Blue	172	173	-	-	197
Palace Blue	174	175	-	-	198
Regal Blue	176	177	-	-	199
Blackout	178	179	-	-	-
Reserved for Future Use	180	255	-	-	-

Category | Lee: 600 Series

Function	8 bit value		16 bit value		Gel Number
Gel Name	From	To	From	To	
Arctic White	0	1	-	-	600
Silver	2	3	-	-	601
Platinum	4	5	-	-	602
Moonlight White	6	7	-	-	603
Full CT 85	8	9	-	-	604
Industry Sodium	10	11	-	-	650
HI Sodium	12	13	-	-	651
Urban Sodium	14	15	-	-	652
LO Sodium	16	17	-	-	653
Blackout	18	19	-	-	-
Reserved	20	255	-	-	-

Category | Lee: Cosmetic Filters

Function	8 bit value		16 bit value		Gel Number
Gel Name	From	To	From	To	
Cosmetic Peach	0	1	-	-	184
Cosmetic Silver Rose	2	3	-	-	186
Cosmetic Rouge	4	5	-	-	187
Cosmetic Highlight	6	7	-	-	188
Cosmetic Silver Moss	8	9	-	-	189
Cosmetic Aqua Blue	10	11	-	-	191
Lily Frost	12	13	-	-	705
Shanklin Frost	14	15	-	-	717
Half Shanklin Frost	16	17	-	-	718
Durham Daylight Frost	18	19	-	-	720
Hampshire Rose	20	21	-	-	749
Soft Amber Key 1	22	23	-	-	774
Soft Amber Key 2	24	25	-	-	775
Moroccan Frost	26	27	-	-	791
Blue Diffusion	28	29	-	-	217
Blue Frost	30	31	-	-	221
Daylight Blue Frost	32	33	-	-	224
Blackout	34	35	-	-	-
Reserved for Future Use	36	255	-	-	-

Category | Lee: 700 Series

Function Gel Name	8 bit value		16 bit value		Gel Number
	From	To	From	To	
Perfect Lavender	0	1	-	-	700
Provence	2	3	-	-	701
Special Pale Lavender	4	5	-	-	702
Cold Lavender	6	7	-	-	703
Lily	8	9	-	-	704
King Fals Lavender	10	11	-	-	706
Cool Lavender	12	13	-	-	708
Electric Lilac	14	15	-	-	709
Spir Special Blue	16	17	-	-	710
Cold Blue	18	19	-	-	711
Bedford Blue	20	21	-	-	712
Elysian Blue	22	23	-	-	714
Cabana Blue	24	25	-	-	715
Mikkel Blue	26	27	-	-	716
Colour Wash Blue	28	29	-	-	719
Berry Blue	30	31	-	-	721
Virgin Blue	32	33	-	-	723
Ocean Blue	34	35	-	-	724
Old Steel Blue	36	37	-	-	725
Steel Green	38	39	-	-	728
Liberty Green	40	41	-	-	730
Dirty Ice	42	43	-	-	731
Damp Squib	44	45	-	-	733
JAS Green	46	47	-	-	738
Bram Brown	48	49	-	-	742
Dirty White	50	51	-	-	744
Brown	52	53	-	-	746
Easy White	54	55	-	-	747
Seedy Pink	56	57	-	-	748
Wheat	58	59	-	-	763
Sun Colour Straw	60	61	-	-	764
LEE Yellow	62	63	-	-	765
Carbox Amber	64	65	-	-	773
Nectarine	66	67	-	-	776
Millenium Gold	68	69	-	-	778
Bastard Pink	70	71	-	-	779
Terry Red	72	73	-	-	781
Blood Red	74	75	-	-	789
Moroccan Pink	76	77	-	-	790
Pretty n'Pink	78	79	-	-	794
Magical Magenta	80	81	-	-	795
Blackout	82	83	-	-	-
Reserved for Future Use	84	255	-	-	-

Category | RC: Color Correction

Function Gel Name	8 bit value		16 bit value		Gel Number
	From	To	From	To	
Full CTB	0	1	-	-	3202
3/4 CTB	2	3	-	-	3203
1/2 CTB	4	5	-	-	3204
1/3 CTB	6	7	-	-	3206
1/4 CTB	8	9	-	-	3208
1/8 CTB	10	11	-	-	3216
Double CTB	12	13	-	-	3220
Full CTO	14	15	-	-	3407
3/4 CTO	16	17	-	-	3411
1/2 CTO	18	19	-	-	3408
1/4 CTO	20	21	-	-	3409
1/8 CTO	22	23	-	-	3410
Double CTO	24	25	-	-	3420
Full CTS	26	27	-	-	3441
1/2 CTS	28	29	-	-	3442
1/4 CTS	30	31	-	-	3443
1/8 CTS	32	33	-	-	3444
Full Plusgreen	34	35	-	-	3304
1/2 Plusgreen	36	37	-	-	3315
1/4 Plusgreen	38	39	-	-	3316
1/8 Plusgreen	40	41	-	-	3317
Full Minusgreen	42	43	-	-	3308
3/4 Minusgreen	44	45	-	-	3309
1/2 Minusgreen	46	47	-	-	3313
1/4 Minusgreen	48	49	-	-	3314
1/8 Minusgreen	50	51	-	-	3318
Fluorofilter	52	53	-	-	3310
Industrial Vapor	54	55	-	-	3150
Urban Vapor	56	57	-	-	3152
Tough Y:1	58	59	-	-	3107
Tough MT 54	60	61	-	-	3134
Tough MTY	62	63	-	-	3106
Tough MT2	64	65	-	-	3102
Blackout	66	67	-	-	
Reserved for Future Use	68	255	-	-	-

Category | RC: CalC

Function Gel Name	8 bit value		16 bit value		Gel Number
	From	To	From	To	
15 Blue	0	1	-	-	4215
30 Blue	2	3	-	-	4230
60 Blue	4	5	-	-	4260
90 Blue	6	7	-	-	4290
7 Cyan	8	9	-	-	4307
15 Cyan	10	11	-	-	4315
30 Cyan	12	13	-	-	4330
60 Cyan	14	15	-	-	4360
90 Cyan	16	17	-	-	4390
15 Green	18	19	-	-	4415
30 Green	20	21	-	-	4430
60 Green	22	23	-	-	4460
90 Green	24	25	-	-	4490
15 Yellow	26	27	-	-	4515
30 Yellow	28	29	-	-	4530
60 Yellow	30	31	-	-	4560
90 Yellow	32	33	-	-	4590
15 Red	34	35	-	-	4615
30 Red	36	37	-	-	4630
60 Red	38	39	-	-	4660
90 Red	40	41	-	-	4690
15 Magenta	42	43	-	-	4715
30 Magenta	44	45	-	-	4730
60 Magenta	46	47	-	-	4760
90 Magenta	48	49	-	-	4790
15 Pink	50	51	-	-	4815
30 Pink	52	53	-	-	4830
60 Pink	54	55	-	-	4860
90 Pink	56	57	-	-	4890
15 Lavender	58	59	-	-	4915
30 Lavender	60	61	-	-	4930
60 Lavender	62	63	-	-	4960
90 Lavender	64	65	-	-	4990
Blackout	66	67	-	-	
Reserved for Future Use	68	255	-	-	-

Category | RC: StSelect

Function	8 bit value		16 bit value		Gel Number
Gel Name	From	To	From	To	
VS Red	0	1	-	-	2001
VS Orange	2	3	-	-	2202
VS Yellow	4	5	-	-	2003
VS Green	6	7	-	-	2004
VS Cyan	8	9	-	-	2005
VS Azure	10	11	-	-	2006
VS Blue	12	13	-	-	2007
VS Indigo	14	15	-	-	2008
VS Violet	16	17	-	-	2009
VS Magenta	18	19	-	-	2010
Blackout	20	21	-	-	-
Reserved	22	255	-	-	-

Category | RC: C-Lux

Function	8 bit value		16 bit value		Gel Number
Gel Name	From	To	From	To	
Bastard Amber	0	1	-	-	2
Pale Bastard Amber	2	3	-	-	302
No Color Straw	4	5	-	-	6
Pale Gold	6	7	-	-	8
Daffodil	8	9	-	-	310
Straw	10	11	-	-	12
Light Amber	12	13	-	-	16
Gallo Gold	14	15	-	-	316
Light Flame	16	17	-	-	17
Flame	18	19	-	-	18
Mayan Sun	20	21	-	-	318
Golden Amber	22	23	-	-	21
Soft Golden Amber	24	25	-	-	321
Orange	26	27	-	-	23
Henny Sky	28	29	-	-	325
Light Red	30	31	-	-	26
No Color Pink	32	33	-	-	33
Blush Pink	34	35	-	-	333
Flesh Pink	36	37	-	-	34
Pale Rose Pink	38	39	-	-	37
Salmon	40	41	-	-	41
Deep Salmon	42	43	-	-	42
Middle Rose	44	45	-	-	44
Light Rose Purple	46	47	-	-	47
Surprise Pink	48	49	-	-	51
No Color Blue	50	51	-	-	60
Clearwater	52	53	-	-	360
Booster Blue	54	55	-	-	62
Tipton Blue	56	57	-	-	362

Category | RC: C-Lux

Function	8 bit value		16 bit value		Gel Number
	From	To	From	To	
Blue Bell	58	59	-	-	364
Daylight Blue	60	61	-	-	65
Tharon Delft Blue	62	63	-	-	365
Cerulean Blue	64	65	-	-	375
Bermuda Blue	66	67	-	-	376
Green Blue	68	69	-	-	77
Alice Blue	70	71	-	-	378
Primary Blue	72	73	-	-	80
Baldassari Blue	74	75	-	-	381
Medium Blue	76	77	-	-	83
Pale Yellow Green	78	79	-	-	87
Light Green	80	81	-	-	88
Moss Green	82	83	-	-	89
Primary Green	84	85	-	-	91
Turquoise	86	87	-	-	92
Blue Green	88	89	-	-	93
Chocolate	90	91	-	-	99
Blackout	92	93	-	-	-
Reserved for Future Use	94	255	-	-	-

X 1 - X 2

Function	8 bit value		16 bit value		Note
	From	To	From	To	
Linear 0.0000 - 0.8500	0	255	0	65535	Default @ 93 (8bit) / 23810 (16bit)

Y 1 - Y 2

Function	8 bit value		16 bit value		Note
	From	To	From	To	
Linear 0.0000 - 0.8500	0	255	0	65535	Default @ 93 (8bit) / 23810 (16bit)

Crossfade - Layer 1 to Layer 2

Function	8 bit value		16 bit value		Note
	From	To	From	To	
Linear, Layer 1 to Layer 2	0	255	0	65535	Default @ 0

Transition Type Channel

Function	8 bit value		16 bit value		Note
	From	To	From	To	
Direct XY	0	9	-	-	Default @ 0 Direct fades linear on the shortest distance. (Constant Brightness)
Standard Direct XY	10	19	-	-	Direct fades linear on the shortest distance. (w/o Constant Brightness)
Through Black	20	29	-	-	"Through Black" fades from color 1 to black to color 2.
Through White 3200K	30	39	-	-	"Through White" fades from color 1 to white to color 2. (w/o Constant Brightness)
Through White 3200K	40	49	-	-	"Through White" fades from color 1 to white to color 2. (Constant Brightness)
Through White 5600K	50	59	-	-	"Through White" fades from color 1 to white to color 2. (w/o Constant Brightness)
Through White 5600K	60	69	-	-	"Through White" fades from color 1 to white to color 2. (Constant Brightness)
Through White 6500K	70	79	-	-	"Through White" fades from color 1 to white to color 2. (w/o Constant Brightness)
Through White 6500K	80	89	-	-	"Through White" fades from color 1 to white to color 2. (Constant Brightness)
Reserved	90	255	-	-	---

Strobe

Function	8 bit value		16 bit value		Note
	From	To	From	To	
Open	0	1	-	-	Default @ 0
Strobe from Slow to Fast	2	62	-	-	
Open	63	64	-	-	
Pulse In from slow to fast	65	125	-	-	
Closed	126	127	-	-	
Pulse Out from slow to fast	128	188	-	-	
Open	189	190	-	-	
Random from slow to fast	191	251	-	-	
Open	252	255	-	-	
Reserved	90	255	-	-	

Preset Channel

Function	8 bit value		16 bit value		Note
	From	To	From	To	
Safe					
No Function	0	1	-	-	Default @ 0
User Defined Presets					
Preset 01	2	3	-	-	Preset saved by user
Preset 02	4	5	-	-	
Preset 03	6	7	-	-	
Preset 04	8	9	-	-	
Preset 05	10	11	-	-	
Preset 06	12	13	-	-	
Preset 07	14	15	-	-	
Preset 08	16	17	-	-	
Preset 09	18	19	-	-	
Preset 10	20	21	-	-	
Preset 11	22	23	-	-	
Preset 12	24	25	-	-	
Preset 13	26	27	-	-	
Preset 14	28	29	-	-	
Preset 15	30	31	-	-	
Preset 16	32	33	-	-	
Preset 17	34	35	-	-	
Preset 18	36	37	-	-	
Preset 19	38	39	-	-	
Preset 20	40	41	-	-	
Reserved	42	167	-	-	
Factory Presets					
Preset 01	168	169	-	-	CCT - 2000K (+/- 0 GN)
Preset 02	170	171	-	-	CCT - 2500K (+/- 0 GN)
Preset 03	172	173	-	-	CCT - 2900K (+/- 0 GN)
Preset 04	174	175	-	-	CCT - 3200K (+/- 0 GN)
Preset 05	176	177	-	-	CCT - 4000K (+/- 0 GN)
Preset 06	178	179	-	-	CCT - 5000K (+/- 0 GN)
Preset 07	180	181	-	-	CCT - 5600K (+/- 0 GN)
Preset 08	182	183	-	-	CCT - 6500K (+/- 0 GN)
Preset 09	184	185	-	-	CCT - 8000K (+/- 0 GN)
Preset 10	186	187	-	-	CCT - 10000K (+/- 0 GN)
Preset 11	188	189	-	-	Source Emulation - HMI
Preset 12	190	191	-	-	Source Emulation - Low Pressure Sodium
Preset 13	192	193	-	-	Source Emulation - CFL Bright White
Preset 14	194	195	-	-	Source Emulation - CFL Cool White
Preset 15	196	197	-	-	Source Emulation - CFL Daylight
Preset 16	198	199	-	-	Source Emulation - Halogen
Preset 17	200	201	-	-	Source Emulation - Candle
Preset 18	202	203	-	-	Source Emulation - Sun Direct
Preset 19	204	205	-	-	Source Emulation - Sun Overcast
Preset 20	206	207	-	-	Source Emulation - Sun Blue Hour
Preset 21	208	209	-	-	HSI - 120° Hue, 100% Saturation
Preset 22	210	211	-	-	HSI - 240° Hue, 100% Saturation
Preset 23	212	213	-	-	GEL - RC 3408, Base CCT 5600K
Preset 24	214	215	-	-	GEL - Lee 187, Base CCT 3200K
Preset 25	216	217	-	-	GEL - RC 3152, Base CCT 3200K
Preset 26	218	219	-	-	GEL - Lee 162, Base CCT 3200K
Reserved	220	255	-	-	---

Fan Control Channel

Function	8 bit value		16 bit value		Note
	From	To	From	To	
Safe					
No Function	0	1	-	-	Use Fan Mode Setting of Fixture Menu
Auto	2	3	-	-	Automatically regulates fan speed - Drops light only if passing the thermal protection treshold.
Turbo	4	5	-	-	Fixed - 100%
Fan Speed	6	107	-	-	Manual Fan Speed: 0% at 6 dmx value - 20% to 100% from 7 to 107 dmx value in linear progression
Dynamic Light Output					
Quiet 1 DLO	108	109	-	-	Fixed Fan Speed (S = 60% ; M = 50% ; L = 50%)
Quiet 2 DLO	110	111	-	-	Fixed Fan Speed (S = 45% ; M = 30% ; L = 35%)
Off DLO	112	113	-	-	Fixed Fan Speed (S = 32% ; M = 22% ; L = 25%)
Constant Light Output					
Quiet 1 CLO	114	115	-	-	Fixed Fan Speed (S = 60% ; M = 50% ; L = 50%)
Quiet 2 CLO	116	117	-	-	Fixed Fan Speed (S = 45% ; M = 30% ; L = 35%)
Off CLO	118	119	-	-	Fixed Fan Speed (S = 32% ; M = 22% ; L = 25%)
Reserved	120	255	-	-	---

Control Channel

Function	8 bit value		16 bit value		Note
	From	To	From	To	
No Function / Safe	0	1	-	-	Default @ 0
Dimmer Speed Auto	2	3	-	-	Hold 3s to take function
Dimmer Speed Fast	4	5	-	-	
Dimmer Speed Medium	6	7	-	-	
Dimmer Speed Slow	8	9	-	-	
Dimmer Speed Off	10	11	-	-	
Reserved for future use	12	13	-	-	
Dimmer Curve Linear	14	15	-	-	
Dimmer Curve S-Curve	16	17	-	-	
Dimmer Curve Square Law	18	19	-	-	
Dimmer Curve Inv. Square Law	20	21	-	-	
Dimmer Curve High Res @ Low	22	23	-	-	
Reserved for future use	24	35	-	-	
Tungsten Emulation On	36	37	-	-	

Control Channel

Function	8 bit value		16 bit value		Note
	From	To	From	To	
Tungsten Emulation Off	38	39	-	-	
Reserved for future use	40	41	-	-	
LED Mode High CRI	42	43	-	-	
Reserved for future use	44	45	-	-	
LED Mode High Brightness	46	47	-	-	
Reserved for future use	48	49	-	-	
Color Space Native	50	51	-	-	
Color Space Pro-Photo	52	53	-	-	
Color Space sRGB	54	55	-	-	
Color Space Rec. 2020	56	57	-	-	
Color Space Rec. 709	58	59	-	-	
Reserved for future use	60	81	-	-	
Fan Mode Auto	82	83	-	-	
Fan Mode Turbo	84	85	-	-	
Fan Mode Quiet 1 Const. Out.	86	87	-	-	
Fan Mode Quiet 2 Const. Out.	88	89	-	-	
Fan Mode Off Const. Out.	90	91	-	-	
Fan Mode Quiet 1 Dyn. Out	92	93	-	-	
Fan Mode Quiet 2 Dyn. Out	94	95	-	-	
Fan Mode Off Dyn. Out	96	97	-	-	
Reserved for future use	98	105	-	-	
Signal Fault Keep Last Frame	106	107	-	-	
Signal Fault On Encoder Touch - CCT mode	108	109	-	-	
Signal Fault On Encoder Touch - RGBW mode	110	111	-	-	
Reserved for future use	112	113	-	-	
Signal Fault StandAlone mode	114	115	-	-	
Signal Fault Blackout	116	117	-	-	
Signal Fault Emergency	118	119	-	-	
Reserved for future use	120	121	-	-	

Control Channel

Function	8 bit value		16 bit value		Note
	From	To	From	To	
Startup Behaviour On Encoder Touch - CCT mode	122	123	-	-	
Startup Behaviour On Encoder Touch - RGBW mode	124	125	-	-	
Reserved for future use	126	127	-	-	
Startup Behaviour StandAlone mode	128	129	-	-	
Startup Behaviour Emergency	130	131	-	-	
Reserved for future use	132	135	-	-	
Led Freq. 1200Hz	136	137	-	-	
Led Freq. 2kHz	138	139	-	-	
Led Freq. 4kHz	140	141	-	-	
Led Freq. 6kHz	142	143	-	-	
Led Freq. 10kHz	144	145	-	-	
Led Freq. 12kHz	146	147	-	-	
Led Freq. 15kHz	148	149	-	-	
Led Freq. 20kHz	150	151	-	-	
Led Freq. 25kHz	152	153	-	-	
Led Freq. 36kHz	154	155	-	-	
Led Freq. 40kHz	156	157	-	-	
Reserved for future use	158	161	-	-	
Power Limit 100%	162	163	-	-	S = 200W ; M = 350W ; L = 600W
Power Limit 75%	164	165	-	-	S = 150W ; M = 250W ; L = 450W
Power Limit 50%	166	167	-	-	S = 100W ; M = 150W ; L = 300W
Power Limit 25%	168	169	-	-	S = 50W ; M = 100W ; L = 150W
Reserved for future use	170	171	-	-	
Backlight Timeout Always On	172	173	-	-	
Backlight Timeout 10s	174	175	-	-	
Backlight Timeout 30s	176	177	-	-	
Backlight Timeout 60s	178	179	-	-	
Backlight Dimmer 25%	180	181	-	-	
Backlight Dimmer 50%	182	183	-	-	
Backlight Dimmer 75%	184	185	-	-	
Backlight Dimmer 100%	186	187	-	-	
Flip Display On	188	189	-	-	
Flip Display Off	190	191	-	-	
Keylock On	192	193	-	-	
Keylock Off	194	195	-	-	

Control Channel

Function	8 bit value		16 bit value		Note
	From	To	From	To	
Reserved for future use	196	249	-	-	
Reset all Control Channel values used	250	251	-	-	
Reserved for future use	252	255	-	-	

Color Correction Mode Selector

Function	8 bit value		16 bit value		Note
	From	To	From	To	
Standard	0	9	-	-	Default @ 0 Color correction occurs with a purely mathematical shift of the xy coordinates
Subtractive Color	10	19	-	-	Color correction occurs by acting on the emitter (i.e. the LED source)
Reserved	30	255	-	-	

Cooler / Warmer

Function	8 bit value		16 bit value		Note
	From	To	From	To	
Cooler/Warmer	0	255	-	-	Default @ 128 Linear Correction from Cooler to Warmer

Desaturate / Saturate

Function	8 bit value		16 bit value		Note
	From	To	From	To	
Desaturate/Saturate	0	255	-	-	Default @ 128 Linear change from a less saturated light to a more saturated light

CC Parameter 1

Function	8 bit value		16 bit value		Note
	From	To	From	To	
Color Correction: Standard Mode					
±Red	0	255	-	-	Default @ 128 Linear change from less Red to more Red as you move through x-y coordinates
Color Correction: Subtractive Color Mode					
±Red	0	255	-	-	Default @ 128 Linear change from less red to more red by varying the emission of the Red LEDs

CC Parameter 2

Function	8 bit value		16 bit value		Note
	From	To	From	To	
Color Correction: Standard Mode					
±Green	0	255	-	-	Default @ 128 Linear change from less Green to more Green as you move through x-y coordinates
Color Correction: Subtractive Color Mode					
±Green	0	255	-	-	Default @ 128 Linear change from less red to more red by varying the emission of the Green LEDs

CC Parameter 3

Function	8 bit value		16 bit value		Note
	From	To	From	To	
Color Correction: Standard Mode					
±Blue	0	255	-	-	Default @ 128 Linear change from less Blue to more Blue as you move through x-y coordinates
Color Correction: Subtractive Color Mode					
±Blue	0	255	-	-	Default @ 128 Linear change from less red to more red by varying the emission of the Blue LEDs

CC Parameter 4

Function	8 bit value		16 bit value		Note
	From	To	From	To	
Color Correction: Standard Mode					
±Cyan	0	255	-	-	Default @ 128 Linear change from less Cyan to more Cyan as you move through x-y coordinates
Color Correction: Subtractive Color Mode					
±Cyan	0	255	-	-	Default @ 128 Linear change from less red to more red by varying the emission of the Cyan LEDs

CC Parameter 5

Function	8 bit value		16 bit value		Note
	From	To	From	To	
Color Correction: Standard Mode					
±Magenta	0	255	-	-	Default @ 128 Linear change from less Magenta to more Magenta as you move through x-y coordinates
Color Correction: Subtractive Color Mode					
±Mint	0	255	-	-	Default @ 128 Linear change from less red to more red by varying the emission of the Mint LEDs

CC Parameter 6

Function	8 bit value		16 bit value		Note
	From	To	From	To	
Color Correction: Standard Mode					
±Yellow	0	255	-	-	Default @ 128 Linear change from less Yellow to more Yellow as you move through x-y coordinates
Color Correction: Subtractive Color Mode					
±Amber	0	255	-	-	Default @ 128 Linear change from less red to more red by varying the emission of the Amber LEDs

12 - ACCESSORIES INSTALLATION

FILTER FRAME (CODE ECLFRCTPMFF)

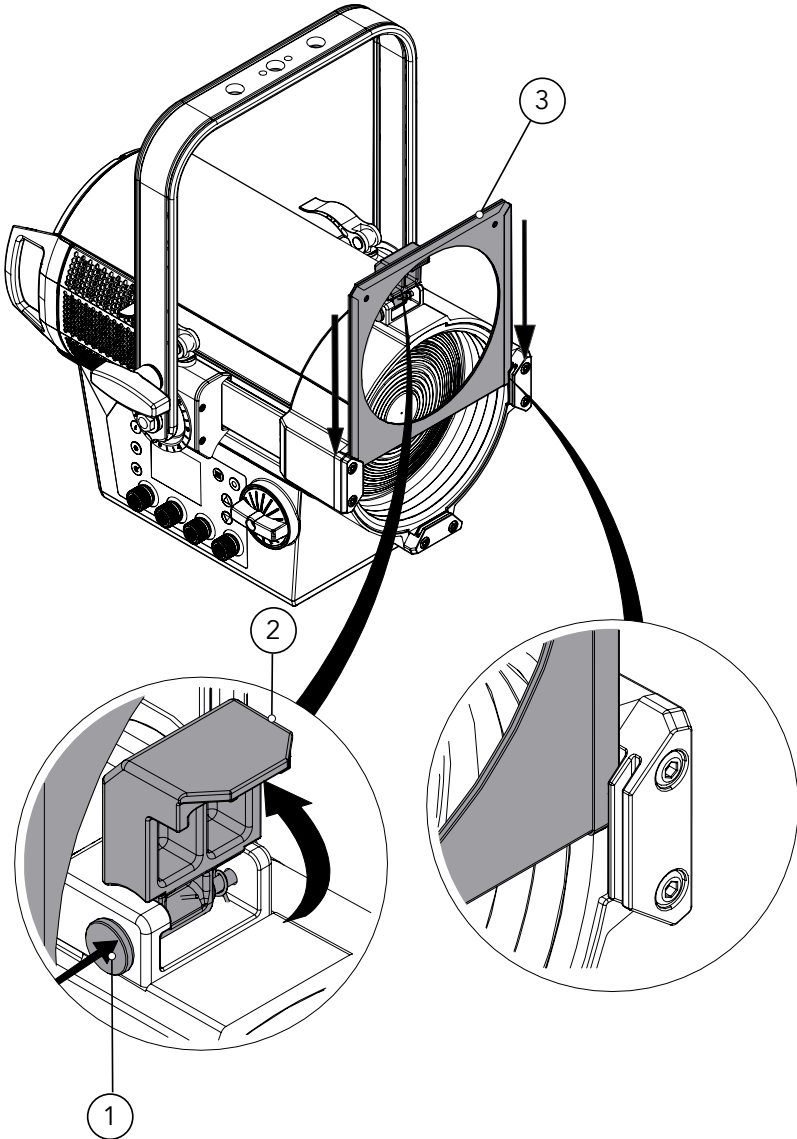

Press the pin (1) and the snap will automatically open upwards (2). Insert the gel filter frame (3) into the gel frame lock (DETAIL) and close down the snap.

NOTE: To remove the accessory, reverse the procedure.

Fig. 09

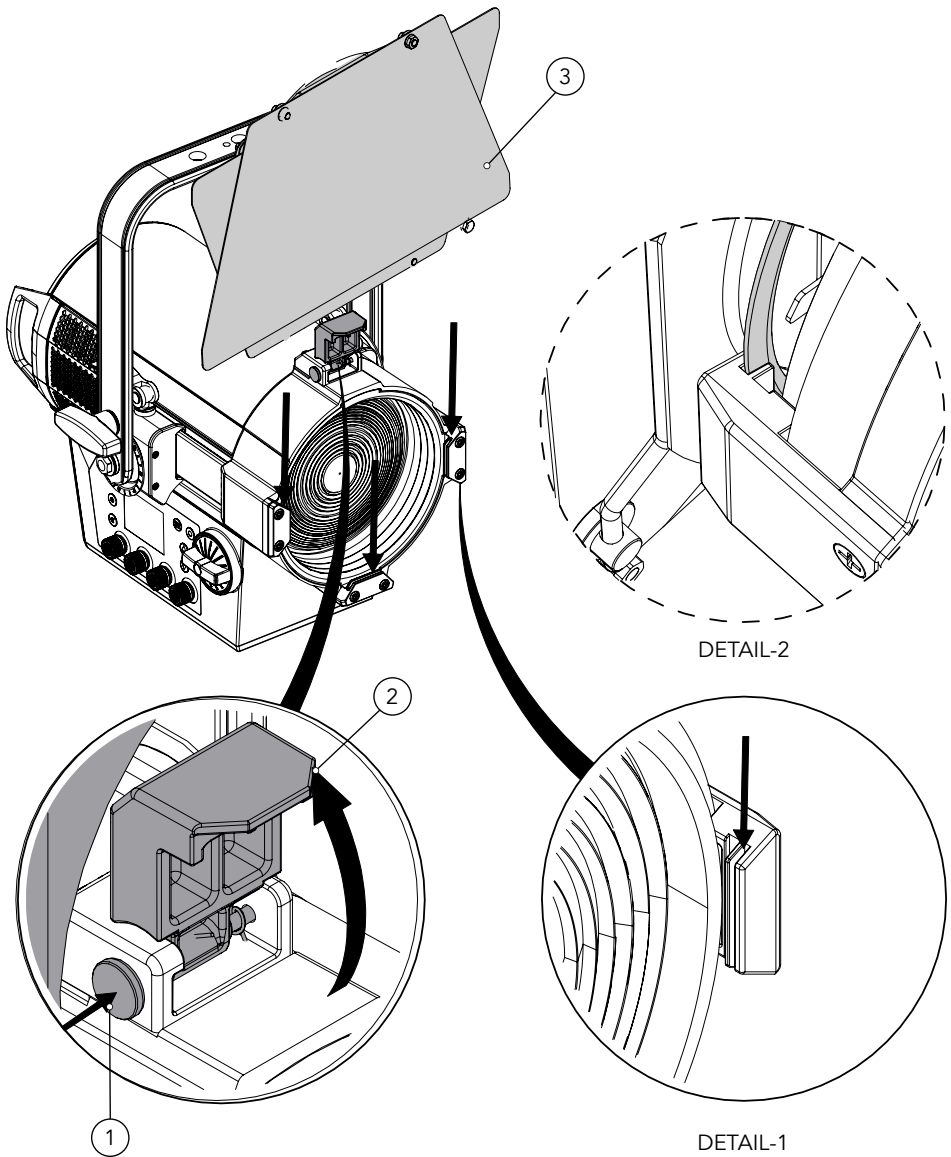

Press the pin (1) and the snap will automatically open upwards (2). Insert the barn door (3) into the gel frame lock (DETAIL-1) through the holder assembly of the barn door (DETAIL-2). Then close down the snap.

NOTE: To remove the accessory, reverse the procedure.

Fig.10

SLIDING BRACKET MOVEMENT

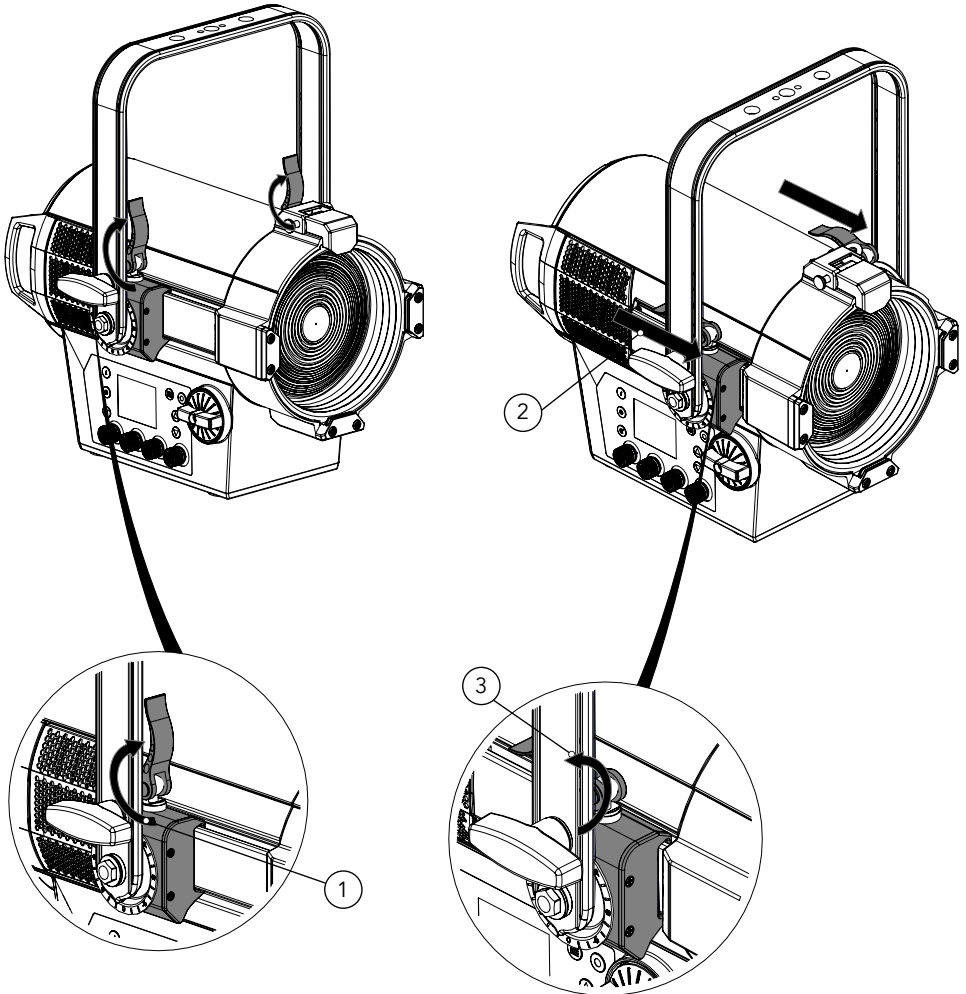

Pull the clip (1) and the bracket will be free to move (2). once the position of the bracket has been chosen, block the movement by closing the clip (3)

Fig. 11

13 - MAINTENANCE

MAINTENANCE AND CLEANING THE PRODUCT

WARNING: Disconnect from the mains before starting any maintenance work

It is recommended to clean the front at regular intervals, from impurities caused by dust, smoke, or other particles to ensure that the light is radiated at maximum brightness.

- For cleaning, disconnect the main plug from the socket. Use a soft, clean cloth moistened with a mild detergent. Then carefully wipe the part dry. For cleaning other housing parts use only a soft, clean cloth. Never use a liquid, it might penetrate the unit and cause damage to it.
- The user must clean the product periodically to maintain optimum performance and cooling. The user may also upload firmware (product software) to the fixture via the DMX signal input port or USB port using firmware and instructions from PROLIGHTS.
- The frequency of such maintenance operations is to be performed according to various factors, such as the amount of the use and the condition of the installation environment (air humidity, presence of dust, salinity, etc.). It is recommended that the product is subject to annual service by a qualified technician for special maintenance involving at least the following procedures:
 - General cleaning of internal parts.
 - For all the parts subject to friction, using lubricants specifically supplied by PROLIGHTS.
 - General visual check of the internal components, cabling, mechanical parts, etc.
 - Electrical, photometric and functional checks; eventual repairs.
 - Cleaning the lenses. Only use neutral soap and water to clean the lenses, then dry it carefully with a soft, non-abrasive cloth.

WARNING: the use of alcohol or any other detergent could damage the lenses.

- All other service operations on the product must be carried out by PROLIGHTS, its approved service agents or trained and qualified personnel.
- It is PROLIGHTS policy to apply the strictest possible calibration procedures and use the best quality materials available to ensure optimum performance and the longest possible component lifetimes. However, optical components are subject to wear and tear over the life of the product, resulting in gradual changes in colours over many thousands of hours of use. The extent of wear and tear depends heavily on operating conditions and environment, so it is impossible to specify precisely whether and to what extent performance will be affected. However, you may eventually need to replace optical components if their characteristics are affected by wear and tear after an extended period of use and if you require fixtures to perform within very precise optical and colour parameters.
- Do not apply filters, lenses or other materials on lenses or other optical components. Use only accessories approved by PROLIGHTS.

REPLACING THE FUSE

WARNING: Before replacing the fuse, unplug the product from the mains.

- Remove the old fuse from the housing with a suitable screwdriver (anticlockwise) and replace it with one of the same type and of the same classification (T6.3A 250V).

VISUAL CHECK OF PRODUCT HOUSING

- The parts of the product cover/housing should be checked for eventual damages and breaking start at least every two months. In addition, especially the parts of the front lens holder have to be checked mechanically (by means of movement by the part) if it is firmly fastened to the fixture. If hint of a crack is found on some plastic part, do not use the product until the damaged part will be replaced.
- Cracks or another damages of the cover/housing parts can be caused by the product transportation or manipulation and also ageing process may influence materials.
- This checking is necessary for both fixed installations and preparing product for renting. Any free moving parts inside of the product, cracked cover/housing or any part of front lens not sitting properly in place need to be immediately replaced.

TROUBLESHOOTING

Problems	Possible causes	Checks and remedies
Product doesn't power ON	<ul style="list-style-type: none"> No power to the product. 	<ul style="list-style-type: none"> Check that power is switched ON and cables are plugged in.
	<ul style="list-style-type: none"> Fuse blown or internal fault. 	<ul style="list-style-type: none"> Check if the Fuse is intact and eventually replace it if necessary. Contact the PROLIGHTS Service or authorized service partner. Do not remove parts and/or covers, or carry out any repairs or service that are not described in this Safety and User Manual unless you have both authorization from PROLIGHTS and the service documentation.
Product reset correctly but does not respond correctly to the controller.	<ul style="list-style-type: none"> Bad signal connection. 	<ul style="list-style-type: none"> Inspect connections and cables. Fix eventual bad connections. Repair or replace damaged cables.
	<ul style="list-style-type: none"> Signal connection not terminated. 	<ul style="list-style-type: none"> Insert DMX termination plug in signal output socket of the last product on the signal line.
	<ul style="list-style-type: none"> Incorrect addressing of the product. 	<ul style="list-style-type: none"> Check the product address and control settings.
	<ul style="list-style-type: none"> One of the product is defective and is corrupting the signal transmission on the signal line. 	<ul style="list-style-type: none"> Unplug the XLR in and out connectors and connect them directly together to bypass one product at a time until normal operation is regained. Once found the error, have that fixture serviced by a qualified technician.
Timeout error after fixture reset.	<ul style="list-style-type: none"> One or more hardware components requires mechanical adjustments. 	<ul style="list-style-type: none"> Check product stored error messages for more information. Contact PROLIGHTS Service or an authorized service partner.
Mechanical effect loses position	<ul style="list-style-type: none"> Mechanical hardware require cleaning, adjustment or lubrication 	<ul style="list-style-type: none"> Check product stored error messages for more information. Contact PROLIGHTS Service or an authorized service partner.
Light output turn OFF Intermittently	<ul style="list-style-type: none"> Fixture is too hot 	<ul style="list-style-type: none"> Check product stored error messages. Allow product to cool. Clean the product and airflow filters. Reduce ambient temperature.
	<ul style="list-style-type: none"> Hardware failure (temperature sensor, fans, Light source...). 	<ul style="list-style-type: none"> Check product stored error messages for more information. Contact. PROLIGHTS Service or an authorized service partner.
General low light intensity	<ul style="list-style-type: none"> Dirty lens assembly. 	<ul style="list-style-type: none"> Clean the fixture regularly.
	<ul style="list-style-type: none"> Dirty or damaged filters. 	<ul style="list-style-type: none"> Install lens assembly properly.

Contact an authorized service center in case of technical problems or not reported in the table can not be resolved by the procedure given in the table.



PROLIGHTS is a trademark of
MUSIC & LIGHTS S.r.l.
musiclights.it

Via A.Olivetti snc
04026 - Minturno (LT) ITALY
Tel: +39 0771 72190

prolights.it
support@prolights.it